

Sentron connection



XJ-L



Bus plugs

## contents

### Busway Systems Overview

General Pricing Notes	15-2
Busway Selector Chart	15-3

### Sentron® Busway

Sentron Busway Overview	15-4 – 15-5
Catalog Numbering System	15-6
Technical Data	15-7 – 15-8
Straight Sections – Feeder, Plug-In, & One-Sided Plug-In	15-9 – 15-10
Busway Straight Sections Aluminum & Copper	15-11
Elbows	15-12 – 15-13
Offsets and Combinations	15-14 – 15-15
Tees	15-16
Tap Boxes	15-17 – 15-21
Expansion Fittings	15-22
Reducers and Phase Rotation Fittings	15-23
Service Heads	15-24
Hangers and End Closers	15-25 – 15-27
Roof and Wall/Ceiling/Floor Flanges	15-28
Busway Accessories	15-29
Flanged Ends, Combination Flange/Elbows	15-30 – 15-32
Cubicle Options	15-33
Panelboards and Meter Center Modules	15-34 – 15-35
Installation and Application Information	15-36
Sentron Busway Quick Reference	15-39
Programs and Services	15-37 – 15-41

### Sentron Bus Plugs

Bus Plug Overview	15-43
Circuit Breaker Bus Plugs	15-44 – 15-49
Fusible Bus Plugs	15-50 – 15-55
SPD Bus Plugs	15-56 – 15-58
3/6 Bus Plugs	15-59 – 15-63

### XJ-L™ HD Busway

Introduction and Overview	15-64 – 15-65
Busway Specifications	15-66
Straight Sections	15-67 – 15-68
Elbows, Tees and Crosses	15-69 – 15-70
Tap Boxes and Flanges	15-71 – 15-73
Accessories - Hangers & End Closers	15-74

### XJ-L HD Bus Plugs

Selection Guide and Catalog Numbering System	15-75
XQ and XQR Series	15-76
XPM Series	15-77
XEC and XLEC Series	15-78
XLVB Series and Plug-in Tap Box	15-79

### Legacy Products

BD® Plug-In (225 - 1600 Ampere) Copper	15-80
XL-U® Aluminum (225–5000 Ampere)	15-81
XL-U Copper (225–6500 Amperes)	15-82
XL-X®, XL-U, BD Plug-In Units	15-83 – 15-84

Scan to connect online to the most up-to-date version of this Section of SPEEDFAX.



# Busway Systems Overview

## Pricing Notes

## General

### A. Footage Pricing

1. Sentron and XL-U base pricing is listed on a per foot charge. When calculating the footage charge, fractions are figured to the next larger number of whole feet (i.e., a linear run totaling 66'3" would be priced at 67 feet.)
2. BD and XJ-L HD base pricing is listed on a per section charge.

### B. Accessories

Some busway accessories are listed as complete device prices while others are listed under accessory charges.

1. Complete device price includes all material and accessory charges for a standard device. (Busway footage included if applicable).
2. Accessory Charge includes fabrication and any miscellaneous fittings for the standard device. (No busway footage included).

**C. End Cable Tap Boxes** are designed to be installed at the beginning or end of a busway run. The busway rating determines the tap box list price. Mechanical lugs are standard. For compression lugs add 30% to tap box list price.

**D. Elbows** with an angle other than 90 degrees, the accessory charge is to be doubled.

**E. Flange Ends (Switchboard Connections / Stubs)** accessory prices are for connection to Siemens equipment. For connection to other manufacturer's equipment, multiply the flange end list price by 2.5. Standard list price includes eight inches of bus extension into equipment from mounting flange, if more than 8 inches required consult factory for pricing. Sentron Switchboards can be assembled with the Busway Flanged End pre-installed, eliminating the labor to connect the Busway to the switchboard at the job site.

**F. Service Heads** are specially constructed tap boxes suitable for outdoor use and are equipped to accept service cables through a removable insulated bottom plate. The busway should be priced through the end of the run.

**G. Phase Transpositions** can be built into a busway section to provide better voltage balance on long runs. To price, use the "Expansion Section" accessory charge for the appropriate ampere rating.

### H. Hangers

Sentron and XL-U busway are UL listed for standard hanger spacing of ten feet (on center). Purchasing busway hangers for horizontal installations is optional. Unistrut/Kindorf is commonly used by contractors as an approved alternative.

Two hangers are furnished free of charge with every straight section of BD and XJ-L HD. Self compensating "Spring" hangers required for vertical installations are designed to be field installed by the installer and are shipped separately. These are also used as intermediate supports where floor-to-floor height is greater than 16 feet.

**I. Ceiling, Floor And Wall Flanges** are used when busway passes through a floor or wall and are intended to cover that portion of the opening around the outside of the busway. **They are not to be used to support the busway.**

**J. Reducers** price is determined by the rating of the larger busway. Fused reducers do not include fuses.

**K. Special Paint — Busway Sections, Accessories And Bus Plugs** Standard finish is ASA #61 light gray. For other than standard color, add 20% and consult factory for availability. XJL HD Busway is offered in ASA#61 Gray and Graphite Gray.

**L. For Silver Finishing of Copper Bus Bars**, add 10%.

**M. Roof Flanges** are specially constructed collars and plates built onto a section of 3R busway which passes through a flat or angled roof. Roof pitch must be given for angled roof.

**N. Circuit Breaker Type Bus Plugs** for Sentron Busways are priced as "complete devices" with circuit breakers factory installed. Circuit Breaker plugs for BD, XL-U and XL-X busways are priced "enclosure only" unless otherwise indicated. XJ-L HD may or may not have a circuit breaker and receptacle installed, depending upon the bus plug type.

**O. Fusible Type Bus Plugs** do not include fuses. Adapter kits for Class R, T & J fuses are available for field installation.

**P. Cubicle** list prices include labor and material for a single frame device with enclosure including line side internal bussing for connection to busway and protective device. Fuses and load side bussing are not included in the base price.

**Q.** Sentron Busway has been tested in accordance with UL1479 and offers a certified two hour fire rating for gypsum wall board construction, and a three hour fire rating for concrete slab or block penetrations. These ratings were achieved using standard busway installed with SpecSeal® sealant from Specified Technologies Inc. This material is available through Electrical Distribution.

### R. Expansion Section

Qty (1) Expansion Section should be used for every 200ft of continuous Busway run length, at every transition to a vertical run, and for each building expansion joint. The Busway run must be positioned accordingly to accommodate the Expansion Section(s).

# Busway Systems Overview

## Busway Selector Chart (100-6500 Ampere)

General

I-T-E (previously known as Bulldog Electric) was the first manufacturer to make a Busway System. Since its introduction in 1932, Busway Systems have improved and expanded into several designs to meet

the ever changing needs of the electrical industry. The Busway Selection Chart below will help you in selecting the proper product to fit your requirements.

## Busway Selector Chart

100-6500 Ampere

600 Volts or Less

Feature		Product			
		Plug-in and Feeder Busway			
		Sentron Plug-in/Feeder	XL-U Plug-in/Feeder	XJ-L HD Plug-in	BD Plug-in
Ampere Rating	100			✓	
	150				
	200				
	225	✓	✓	✓	✓
	400	✓	✓	✓	✓
	600	✓	✓		✓
	800	✓	✓		✓
	1000	✓	✓		✓
	1200	✓	✓		✓
	1350	✓	✓		✓
	1600	✓	✓		✓
	2000	✓	✓		
	2500	✓	✓		
	3000	✓	✓		
	3200	✓			
	4000	✓	✓		
	5000	✓	✓		
6000, 6500		✓			
Conductor	Copper	✓	✓	✓	✓
	Aluminum	✓	✓		
Use	Indoor	✓	✓	✓	✓
	Outdoor	✓	✓		
AC Service 50-60 Hz 400Hz <sup>①</sup>	2W				
	1Ø3W			✓	
	3Ø3W	✓	✓	✓	✓
	3Ø4W 100% N	✓	✓	✓	✓
	3Ø4W 200% N	✓		✓	
Voltage	600 volts or less	✓	✓	✓	✓
Construction	Ventilated		✓		
	Non-Ventilated	✓	✓	✓	✓
Meets Electrical Standard	<b>UL</b> 857	✓	✓	✓	✓
	<b>NEMA</b> BU1	✓	✓	✓	✓
	<b>CSA/CUL</b> C22.2 NO 27	✓	✓	✓	✓
	<b>ANCE</b> NMX-J-148ANCE	✓	✓	✓	✓

① Consult factory for information.

# Sentron Busway Systems

## Sentron Busway Overview

## Overview

### Sentron Busway for Global Power Distribution Applications

Building on a solid foundation of advanced products for the construction industry, the Siemens Sentron name is recognized worldwide as synonymous with quality and consistent performance. Sentron Busway delivers impressive features and benefits that make it ideal for many types of industrial and construction implementations.

Engineered to ensure the safe and efficient distribution of power in industrial, commercial and institutional environments world-wide, Sentron ampacities range from 225A to 5000A UL. Thanks to an innovative design, you benefit from labor-saving installation and a flexible, compact bus system that is an ideal fit for most applications. In fact, Sentron Busway is one of the industry's least labor-intensive systems.

Sentron Busway installs with minimal hardware and often costs less than cable and conduit installations. The lightweight aluminum housing acts as an integral ground, joint stacks connect with splice plates featuring a single-bolt design, and bus plugs and cable tap boxes offer the industry's largest wire bending space. An optional 200% neutral within the bus bar housing accommodates harmonics common in today's power systems.

Sentron Busway conductors are insulated with a state-of-the-art epoxy insulation system, which is applied using an electrostatic spray process for optimal insulation integrity.

Exemplifying the spirit of continuing innovation, Sentron Busway is now available with economical and convenient elbow stacks for changing left, right, up or down directions at 90 degrees.

And, of course, Sentron Busway is certified to design standards worldwide, including UL, NEMA, IEC, CSA, VDE and BS.

Siemens Busway Business uses industry leading technology in all its manufacturing processes. From bus bar fabrication to Electrostatic Spray Epoxy insulation, all the processes used in the manufacturing of Siemens Sentron Busway are electronically controlled to provide for consistent, high quality results, making Sentron Busway products best in its class.

#### Housing

Sentron Busway incorporates an all aluminum housing. This lightweight totally enclosed, non-ventilated housing resists rust and other elements, distributes heat away from the conductors, and provides an excellent ground path. The totally enclosed design also eliminates the need for derating of the system regardless of installation orientation. The housing is covered with an electrostatically applied light gray ANSI 61 polyester urethane powder paint that is scratch resistant and has a 1,000-hour salt spray resistance rating.

#### Conductors

Sentron Busway conductors have a compact construction and can be configured as 3-phase 3-wire, 3-phase 4-wire or 3-phase 4-wire with 200% neutral. The conductors may be ordered in copper (98% conductivity), 1000A/in<sup>2</sup> M-Rated Copper, Aluminum (58% conductivity) and 750A/in<sup>2</sup> L-Rated Aluminum. The optional 200% neutral helps to handle harmonic conditions that may exist. This system is especially useful with discharge lighting (fluorescent) and computer installations. This will help to minimize overheating and prolong the life cycle of your power distribution equipment.

#### Ground

Sentron Busway offers ground options to meet your specifications: standard integral aluminum housing ground and optional internal grounding bars. An optional isolated ground is also available which is especially useful in applications where a clean ground is needed (such as hospitals or high tech).

#### Plating

All bus bars are electroplated with tin. This unique tin plating provides excellent conductivity and prevents impurities from attaching to the bars. Optional silver plating is also available with a copper conductor only.

#### Insulation

Sentron Busway is insulated with an Epoxy Powder Coating system designed by Siemens Engineers, Epoxy System Engineers and Epoxy Powder Specialists, specifically for Siemens Busway products.

The Siemens exclusive Electrostatic Spray insulation process produces uniform application of Epoxy powder over the entire conductor bar. This is further enhanced by the inline filter process and magnetic separator that helps to eliminate contaminants common to fluidized bed systems. The electrostatic application also provides a better coating consistency than that of the older fluidized bed process. The combination of electrostatic spray and lower oven temperatures produces a consistent coverage with fewer impurities and pinholes in the insulation. The lower oven temperatures reduce the risk of bar annealing, which affects the overall quality of the system.

Sentron Busway insulation is Class B, 130°C Rated. Every bus bar and completed assembly is dielectric tested to ensure the insulation is free of defects.

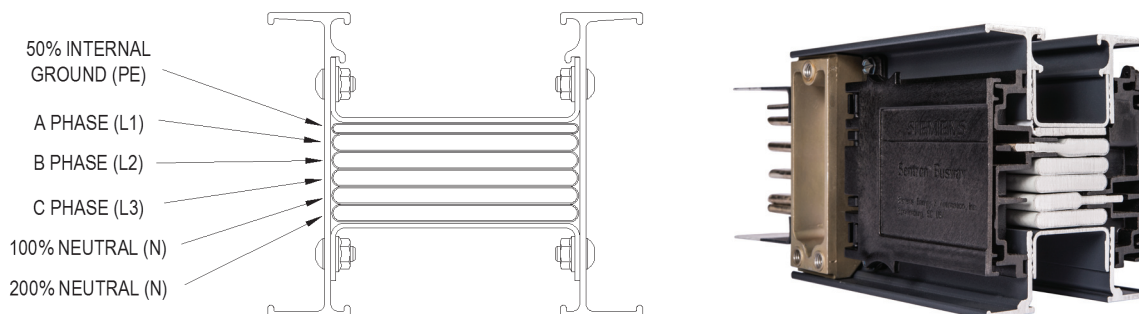



# Sentron Busway Systems

## Sentron Busway Overview

## Overview

### Joint Stack

Each Sentron Busway piece is shipped with a joint stack and joint covers installed at one end of the busway and a shipping end protector at the other end. The joint stacks feature a single bolt design and a special, torque indicating, double headed break-off bolt. This eliminates the need for torque wrenches and assures proper torque at installation of 50 ft.-lbs.(68 N-m).

When the proper torque value is achieved, the top bolt head will shear off. Each joint stack allows for +/- .625 inches (15.8mm) adjustability at each joint. Over adjustment is prevented by the joint covers, which will only allow a .625 inch (15.8mm) adjustment when the knockouts on the joint cover are removed.

It is possible to remove any joint connection assembly to allow electrical isolation or removal of a busway length without disturbing adjacent busway lengths. Isolation joint stacks are available and used to electrically isolate a busway section(s) within a busway run. For easy visual identification, isolation joint stack assemblies are painted white.

### Plug-in Opening

Sentron Busway offers plug-in style busway which feature plug-in openings rated for finger safety to IP2X in accordance with IEC 529 and BS EN 60439-1, -2 and BS EN 60529.

Each plug-in opening has a reversible hinged dead front designed to protect the contact surfaces from dirt, dust or moisture. Gasketing is used where applications require a splash proof (IP55) rating.

### IP Ratings

Sentron Busway is available in a variety of IP ratings. Use the chart below to determine the IP rating that best fits your application needs.

### Testing

Each piece of Sentron Busway is factory tested before shipping. Tests performed include dielectric tests, which are used to insure integrity of insulation. In addition, Sentron Busway is tested in accordance with both UL and IEC standards. All Sentron Busway is manufactured and inspected in an ISO 9001:2000 registered facility.

### Standards

All Sentron Busway products meet the following standards:

- UL 857
- NEMA BU1
- CSA C22.2
- IEC 60529 (2004)
- BS EN 60529
- BS EN 60439-1, 60439-2
- UL 1479
- DIN 4102 Parts 9&12
- BS 6387 Parts 11.1 and 11.2

### Labor Savings

Using Sentron Busway instead of cable and conduit can create savings of up to 20 - 30% on total installed costs. Sentron busway is lightweight, compact and takes half the time to install as cable and conduit. For more information, visit our web site at [www.sea.siemens.com](http://www.sea.siemens.com).

Watch the Joint Assembly video

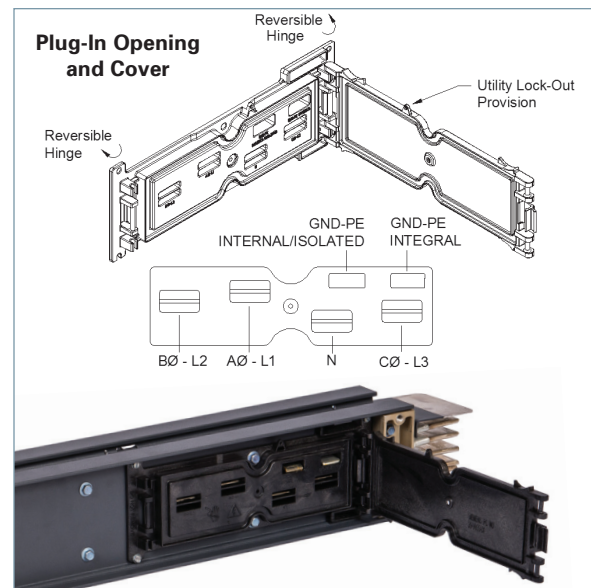
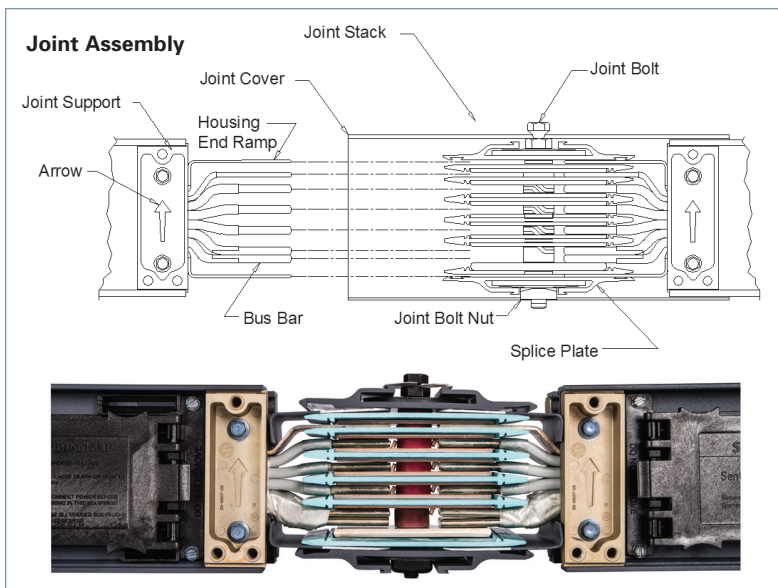

### Levels of Protection Description

Code	Description	Sentron Busway		
		Feeder	Plug-In	Sentron Bus Plugs
IP 2X	Plug-In outlet protects against access to live parts by .472 in. (12 mm) test probe, even with cover opened. <b>Finger Safe</b>	•	•	•
IP 40	Enclosure protects against entry of .039 in. (1.0 mm) test probe. <b>Indoor</b> (Typical UL Designation)	•	•	•
IP 55	Enclosure protects against entry of dust and water jets. <b>Splash Proof</b>	•	•	•
IP 66	Enclosure is dust tight and protects against powerful water jets. <b>Outdoor</b> (International Only)	•		
NEMA 3R	Enclosure protects against rain, sleet and damage from ice formation. <b>Outdoor</b>	•		

# Sentron Busway Systems

## Catalog Numbering System

## Selection

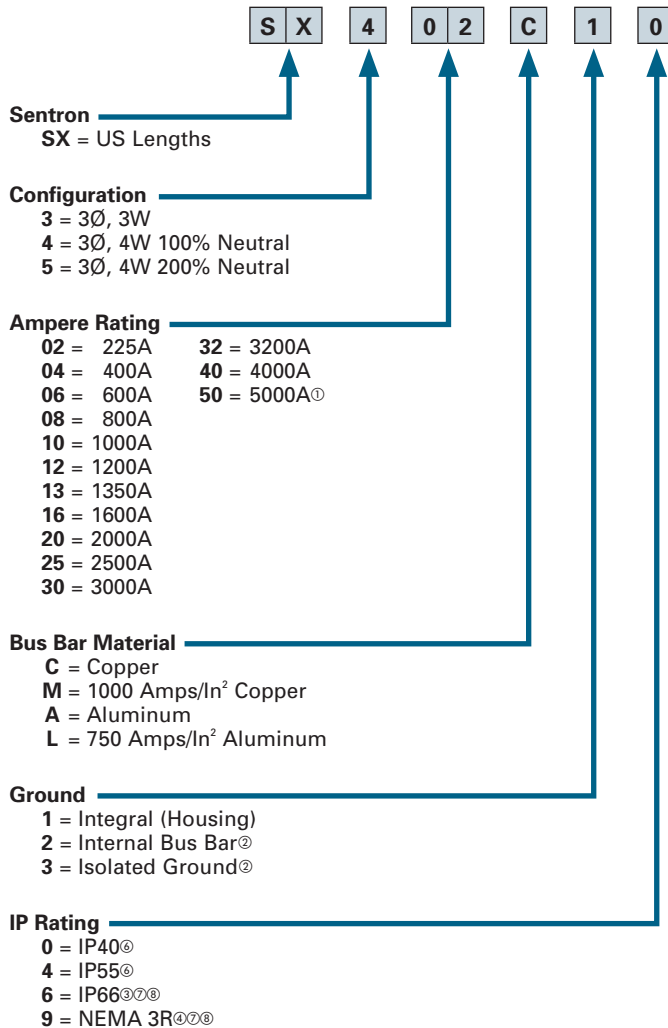

① Copper only  
② Copper or aluminum ground bar  
③ IEC Markets  
④ NEMA Markets  
⑤ For odd degree angle (other than 90°) specify the degree angle of the turn.  
⑥ Indoor only (Plug-in and Feeder)  
⑦ Outdoor use (Feeder only)  
⑧ Elbow Stack (IP40 and IP55 only)



## Suffix part of Catalog Numbers

	P	L	0	6
Feeder			Length in Inches, ex.: 2'3" = 027 Feeder lengths available from 1'3" (024 Inches) up to 10'0" (120 inches)	
Plug-in	L		Length	04 = 4'0" 06 = 6'0" 08 = 8'0" 10 = 10'0"
One-sided plug-in (Riser)	I		Length	04 = 4'0" 06 = 6'0" 08 = 8'0" 10 = 10'0"
Elbows	S = Stack <sup>®</sup> L = 90° O = Odd degree angle <sup>®</sup>	Edge		Up Down
		Flat		Right Left
Tees	E	Edge		Up Down
		Flat		Right Left
Offsets	F	Edge		Up Down
		Flat		Right Left
Combinations	O	Edge Up		Flat Left
		Edge Down		Flat Left
		Edge Up		Flat Right
		Edge Down		Flat Right
		Flat Left		Edge Up
		Flat Left		Edge Down
		Flat Right		Edge Up
		Flat Right		Edge Down
EXpansion Fittings	P		F	T
Center Cable Tap Boxes	T		B	Standard EXpanded
End Cable Tap Boxes	T		Vertical Horizontal	Standard EXpanded
Joint Mounted Tap Boxes	T		Vertical Horizontal	Left Right Both
End Closers	C		L	S
FlanGe	Roof Wall		F	L
Joint Stacks	Standard Isolation		S	T
SerVice Heads	1 = 1-Phase 3 = 3-Phase T = Throat	Transformer		H
		Utility		Florida Pwr/Light Houston Pwr/Light Commonwealth ED Pacific Gas/Electric Detroit Edison San Diego Seattle Other
Reducers	Fused		R	F
	Non-fused		R	N
Flanged End	E = Int'l Standard		N	D
	R = U.S. Standard		N	D
	O = Other			
Transposition	R		PG = Phase & Ground PO = Phase only GO = Ground only	

# Sentron Busway Systems

Technical Data

Technical

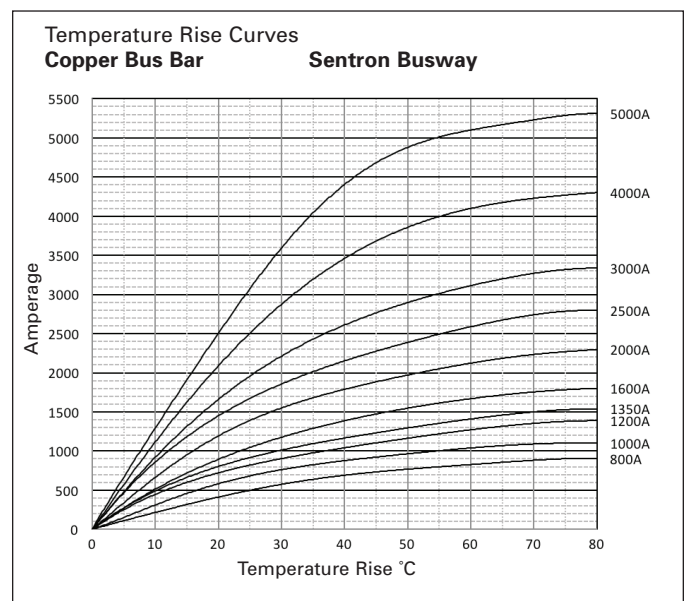
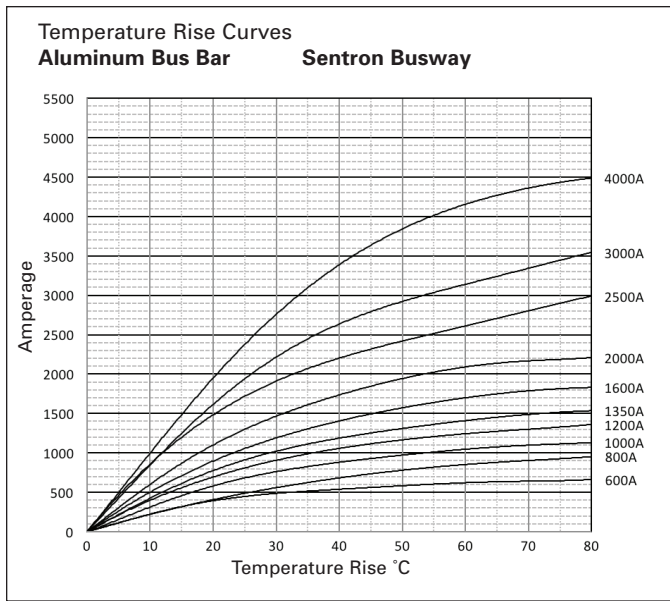

## R, X, Z and Ohms, Voltage Drop

Ampere Rating	Bus Bar Width x 0.25 in. (6.4mm) Thick	Ohms x 10 <sup>-3</sup> per 100 feet			Voltage Drop - Concentrated Loads, Line-to-Line per 100 feet at 100% Rated Load, 35°C Ambient <sup>①③⑦</sup>							
		Line to Neutral R	X	Z	Power Factor 0.3	0.4	0.5	0.6	0.7	0.8	0.9	1.0
<b>AL L-Rated<sup>③</sup></b>												
225 —	1.75 (44.5)	3.94	1.13	4.10	0.88	1.02	1.15	1.27	1.39	1.49	1.57	1.54
400 —	1.75 (44.5)	4.08	1.23	4.26	1.66	1.91	2.15	2.38	2.58	2.77	2.91	2.83
600 —	1.75 (44.5)	4.26	1.32	4.46	2.64	3.03	3.40	3.75	4.08	4.37	4.58	4.43
800 400	2.38 (60.5)	3.42	1.06	3.58	2.82	3.24	3.64	4.02	4.36	4.67	4.90	4.74
1000 600	3.25 (82.6)	2.45	0.74	2.56	2.50	2.88	3.24	3.57	3.89	4.17	4.38	4.24
1200 800	4.38 (111.3)	1.86	0.59	1.95	2.32	2.66	2.99	3.29	3.58	3.82	4.01	3.87
1350 1000	5.38 (138.7)	1.39	0.24	1.41	1.50	1.81	2.10	2.39	2.67	2.93	3.17	3.25
1600 1200	6.50 (165.1)	1.21	0.45	1.29	2.19	2.48	2.75	3.00	3.23	3.43	3.56	3.35
2000 1350,1600	8.75 (222.3)	0.91	0.35	0.98	2.11	2.38	2.64	2.87	3.08	3.26	3.37	3.16
2500 2000	(2) 5.63 (143.0)	0.68	0.29	0.74	2.09	2.34	2.57	2.78	2.97	3.12	3.21	2.95
3000 2500	(2) 6.75 (171.5)	0.54	0.28	0.61	2.24	2.47	2.67	2.85	3.01	3.12	3.16	2.80
3200 2000	(2) 7.50 (190.5)	0.48	0.33	0.58	2.53	2.73	2.91	3.06	3.17	3.23	3.20	2.68
4000 3000,3200	(2) 9.00 (228.6)	0.46	0.21	0.51	2.34	2.61	2.85	3.08	3.27	3.43	3.51	3.20
<b>CU M-Rated<sup>③</sup></b>												
225 —	1.75 (44.5)	2.34	1.13	2.60	0.69	0.77	0.84	0.90	0.95	0.99	1.01	0.91
400 —	1.75 (44.5)	2.44	1.13	2.69	1.26	1.40	1.52	1.64	1.74	1.82	1.86	1.69
600 —	1.75 (44.5)	2.58	1.16	2.83	1.96	2.18	2.39	2.58	2.74	2.87	2.94	2.68
800 400	1.75 (44.5)	2.71	1.17	2.95	2.67	2.98	3.28	3.55	3.78	3.97	4.08	3.76
1000 —	2.25 (67.2)	2.12	0.89	2.30	2.58	2.88	3.17	3.44	3.67	3.86	3.98	3.67
1200 600	2.88 (73.2)	1.66	0.77	1.83	2.56	2.85	3.11	3.35	3.56	3.72	3.80	3.45
1350 800	3.50 (88.9)	1.30	0.64	1.45	2.34	2.59	2.82	3.03	3.20	3.33	3.39	3.04
1600 1000	4.50 (114.3)	1.06	0.56	1.20	2.37	2.60	2.82	3.01	3.17	3.29	3.32	2.94
2000 1200,1350	6.00 (152.4)	0.77	0.44	0.89	2.27	2.48	2.66	2.83	2.96	3.05	3.07	2.66
— 1600	—	—	—	—	—	—	—	—	—	—	—	—
2500 2000	8.50 (215.9)	0.53	0.35	0.65	2.15	2.34	2.50	2.64	2.75	2.82	2.81	2.39
3000 —	(2) 4.75 (120.7)	0.49	0.27	0.56	2.07	2.28	2.46	2.62	2.76	2.86	2.89	2.54
3200 —	(2) 5.50 (139.7)	0.44	0.30	0.53	2.33	2.51	2.67	2.80	2.90	2.96	2.93	2.44
4000 2500,3000,3200	(2) 6.50 (165.1)	0.39	0.26	0.47	2.50	2.71	2.89	3.04	3.16	3.23	3.21	2.71
5000 4000	(2) 8.50 (215.9)	0.30	0.21	0.37	2.49	2.69	2.86	3.00	3.11	3.17	3.15	2.63

**Notes:**

- ① For plug-in distributed loads, divide voltage drop values by 2.
- ② To determine voltage drop line-to-neutral, multiply line-to-line values by 0.577.
- ③ Actual voltage drop for different lengths and at loadings less than full rated current can be calculated using the formula:  

$$Vd \text{ (actual)} = Vd \text{ (table)} \times \frac{\text{actual load}}{\text{rated load}} \times \frac{\text{actual length (ft)}}{100 \text{ feet}}$$

- ④ For 50 Hz, multiply reactance (X) by 0.85 and resistance values do not change. For 400 Hz, multiply reactance by 3.75 and multiply resistance by 1.4. Calculate new voltage drop:  

$$Vd = \text{amps load} \times \sqrt{3(R\cos\theta + X\sin\theta)} \text{ per 100 ft, where } \cos\theta = \text{Power Factor.}$$
- ⑤ For metric conversion R, X, Z values "in Ohms per meters Line to Neutral"  
 R x .0328  
 X x .0328  
 Z x .0328

- ⑥ For metric conversion "Line to Line per meter at 25° C ambient in mV/A/m" (Vd 32.8) / A. Divide Vd by 2 for distributed loads.
- ⑦ Voltage Drop will decrease in lower ambient temperature. Contact Siemens for Voltage Drop in other ambient conditions.

# Sentron Busway Systems

Technical Data

Technical

## Ground Capacity

Ampere Rating	Bus Bar Width Inches (mm)	Bars per Pole	Min. CSA for Ground Bus per UL 857 Table 14 In2 (mm2)	Sectional Area 50% Internal Ground Bar In2 (mm2)	Integral (Hsg.) Ground In2 (mm2)	Effective Current Carrying Capacity of Housing		Grd. Circuit Characteristics under Fault Conditions Ohms x 10 <sup>-3</sup> per 100 ft					
						% of UL Req	% of Phase Bar	Internal Ground			Housing Ground		
								R	X	Z	R	X	Z
<b>A L-Rated</b>													
225 —	1.75 (44.5)	1	0.08 (53.5)	0.22 (141.1)	2.30 (1485.1)	1333	253	4.872	9.037	10.267	5.797	12.963	14.200
400 —	1.75 (44.5)	1	0.17 (107.1)	0.22 (141.1)	2.30 (1485.1)	667	253	4.872	9.037	10.267	5.797	12.963	14.200
600 —	1.75 (44.5)	1	0.17 (107.1)	0.22 (141.1)	2.30 (1485.1)	667	253	4.872	9.037	10.267	5.797	12.963	14.200
800 400	2.38 (60.5)	1	0.17 (107.1)	0.30 (191.9)	2.40 (1550.1)	688	192	3.351	7.333	8.063	4.932	10.000	11.150
1000 600	3.25 (82.6)	1	0.20 (126.5)	0.41 (262.1)	2.54 (1639.9)	607	147	2.833	6.628	7.208	3.662	8.442	9.202
1200 800	4.38 (111.1)	1	0.23 (146.5)	0.55 (352.8)	2.72 (1756.6)	552	115	2.487	5.852	6.358	3.189	6.926	7.625
1350 1000	5.38 (136.5)	1	0.29 (189.7)	0.67 (433.5)	2.88 (1859.8)	446	94	2.182	5.115	5.561	2.713	5.883	6.478
1600 1200	6.50 (165.1)	1	0.29 (189.7)	0.81 (524.2)	3.06 (1975.4)	467	84	1.801	4.489	4.837	2.289	5.206	5.687
2000 1350,1600	8.75 (222.3)	1	0.35 (227.7)	1.09 (705.6)	3.42 (2207.7)	425	69	1.390	3.467	3.735	1.623	4.267	4.565
2500 2000	5.63 (142.9)	2	0.52 (332.3)	1.41 (907.3)	3.85 (2480.7)	320	59	1.145	2.955	3.169	1.526	3.837	4.129
3000 2500	6.75 (171.5)	2	0.59 (380.0)	1.69 (1088.7)	4.20 (2711.9)	301	53	0.954	2.683	2.848	1.221	3.635	3.835
3200 2000	7.50 (190.5)	2	0.81 (522.6)	1.88 (1209.7)	4.44 (2866.8)	229	51	0.894	2.493	2.648	1.144	3.428	3.614
4000 3000,3200	9.00 (228.6)	2	0.81 (522.6)	2.25 (1451.6)	4.92 (3176.5)	250	50	0.715	2.339	2.446	0.916	3.378	3.500
<b>CU M-Rated</b>													
225 —	1.75 (44.5)	1	0.05 (33.5)	0.22 (141.1)	2.30 (1485.1)	2128	261	3.803	6.330	7.380	5.183	10.083	11.338
400 —	1.75 (44.5)	1	0.11 (67.7)	0.22 (141.1)	2.30 (1485.1)	1054	261	3.803	6.330	7.380	5.183	10.083	11.338
600 —	1.75 (44.5)	1	0.11 (67.7)	0.22 (141.1)	2.30 (1485.1)	1054	261	3.803	6.330	7.380	5.183	10.083	11.338
800 400	1.75 (44.5)	1	0.11 (67.7)	0.22 (141.1)	2.30 (1485.1)	1054	261	3.803	6.330	7.380	5.183	10.083	11.338
1000 —	2.25 (57.2)	1	0.13 (85.2)	0.28 (181.5)	2.38 (1536.7)	860	207	3.029	5.993	6.715	4.409	9.191	10.194
1200 600	2.88 (73.0)	1	0.18 (114.2)	0.36 (231.9)	2.48 (1601.8)	661	166	2.460	5.676	6.186	3.674	8.212	8.996
1350 800	3.50 (88.9)	1	0.24 (152.3)	0.44 (282.3)	2.58 (1665.8)	510	140	2.188	5.267	5.704	2.807	7.492	8.000
1600 1000	4.50 (114.3)	1	0.24 (152.3)	0.56 (362.9)	2.74 (1769.0)	534	113	1.893	4.323	4.719	2.756	6.880	7.411
2000 1200,1350	6.00 (152.4)	1	0.29 (189.7)	0.75 (483.9)	2.98 (1923.8)	457	90	1.476	3.181	3.507	2.205	6.032	6.422
— 1600	6.50 (165.1)	1	0.29 (189.7)	0.81 (524.2)	3.06 (1975.4)	467	84	1.801	4.489	4.837	2.289	5.206	5.687
2500 2000	8.50 (215.9)	1	0.35 (227.7)	1.06 (685.5)	3.38 (2181.9)	421	70	1.087	2.020	2.294	1.764	5.419	3.072
3000 —	4.75 (120.7)	2	0.41 (265.8)	1.19 (766.1)	3.56 (2290.0)	376	66	0.984	1.874	2.117	1.470	4.631	4.859
3200 —	5.50 (139.7)	2	0.59 (380.0)	1.38 (887.1)	3.80 (2453.9)	277	60	0.947	1.691	1.938	1.378	4.129	4.353
4000 2500,3000,3200	6.50 (165.1)	2	0.59 (380.0)	1.63 (1048.4)	4.12 (2660.3)	296	54	0.773	1.500	1.688	1.323	3.060	3.334
5000 4000	8.50 (215.9)	2	0.71 (456.1)	2.13 (1371.0)	4.76 (3073.2)	278	50	0.606	1.218	1.360	0.882	1.783	1.989

Note: Bus bar thickness = .25 in. (6.4mm), Ground bar thickness = .125 in.(3.18mm)

UL Short Circuit Ratings				UL Series Connected with Fuse			
Ampere Rating	L-Rated	RMS Symmetrical (kA)			Maximum Fuse Size for 200kA		
		6 cycle	1 sec.	3 sec.	Class R	Class J & T	Class L
225 —	—	85	28	16	600	600 J & T	—
400 —	—	85	28	16	600	600 J & T	—
600 —	—	85	28	16	600	600 J & T	—
800 400	—	100	47	27	—	800 T	1200
1000 600	—	100	50	29	—	—	3000
1200 800	—	125	60	35	—	—	3000
1350 1000	—	150	75	43	—	—	3000
1600 1200	—	150	90	52	—	—	3000
2000 1350,1600	—	150	110	64	—	—	5000
2500 2000	—	200	130	75	—	—	5000
3000 2500	—	200	160	92	—	—	—
3200 2000	—	200	160	92	—	—	—
4000 3000,3200	—	200	200	115	—	—	—
<b>CU M-Rated</b>							
225 —	—	85	40	23	600	600 J & T	—
400 —	—	85	40	23	600	600 J & T	—
600 —	—	85	40	23	600	600 J & T	—
800 400	—	85	40	23	—	800 T	1600
1000 —	—	100	50	29	—	—	3000
1200 600	—	100	65	38	—	—	3000
1350 800	—	100	80	46	—	—	3000
1600 1000	—	125	95	55	—	—	4000
2000 1200,1350	—	150	115	66	—	—	5000
— 1600	—	150	90	52	—	—	3000
2500 2000	—	150	130	75	—	—	5000
3000 —	—	200	175	101	—	—	—
3200 —	—	200	175	101	—	—	—
4000 2500,3000,3200	—	200	200	115	—	—	—
5000 4000	—	200	200	115	—	—	—

Sentron Busway has UL approved Series Ratings. By using the appropriate line side fuse, short circuit ratings can be enhanced to 200kA for lower amperage busway.

# Sentron Busway Systems

## Straight Sections – Plug-In, One-Sided Plug-In and Feeder

Selection

### Straight Sections

Sentron Busway can be ordered with Aluminum or Copper bus bars. Aluminum bars are available in 225-4000 ampere sections. Copper bars are available in 225-5000 ampere sections. Sentron Busway includes an integral housing ground, and is available with an internal ground bar or an isolated ground bar in all ampere ratings. Sentron Busway housing is a four-piece aluminum design.

### Plug-In Sections

Sentron plug-in sections are designed with plug-in openings centered on 24 in. (610mm) intervals, and are located on both sides of the busway for optimum utilization. Plug-in sections are available in standard lengths of 4 ft. (1.22m), 6 ft. (1.83m), 8 ft. (2.44m) and 10 ft. (3.05m). Sentron plug-in sections meet IP40

(indoor) and IP55 (splash proof) requirements. One joint stack assembly is provided with each plug-in section.

### One-Sided Plug-In Sections

Sentron one-sided plug-in sections are designed with plug-in openings centered on 24 in. (610mm) intervals on one side of the busway only. This eliminates unusable plug-in outlets in vertical applications. One-sided plug-in busway is available in standard lengths of 4 ft. (1.22m), 6 ft. (1.83m), 8 ft. (2.44m) and 10 ft. (3.05m). Sentron one-sided plug-in busway is available in IP40 (indoor) and IP55 (splash proof). One joint stack assembly is provided with each section.

### Plug-In Outlet Features

The plug-in outlet molded guard design prevents incidental finger contact with live conductors. Sentron plug-in outlets

are IP 2X rated (with the outlet cover open) which means a .472 in. (12mm) or larger probe is unable to enter a plug-in outlet. The outlet is IP40 Rated with the cover closed and IP55 Rated when configured with gaskets.

### Feeder Sections

Feeder busway carries the current of the busway system from the supply source. Feeder busway does not have plug-in outlets. Sentron Feeder busway is available in custom lengths from 15 in. (0.37m) to 10 ft. (3.05m). Feeder sections are rated as IP40 (Indoor), IP55 (Splash Proof), NEMA 3R (Outdoor), and IP66 (International Outdoor). One joint stack assembly is provided with each feeder section.

**Standard Plug-In Section (Standard plug-in outlets on both sides on 24 in. centers)**  
Suffix PL04 (4 ft.), PL06 (6 ft.), PL08 (8 ft.), PL10 (10 ft.)

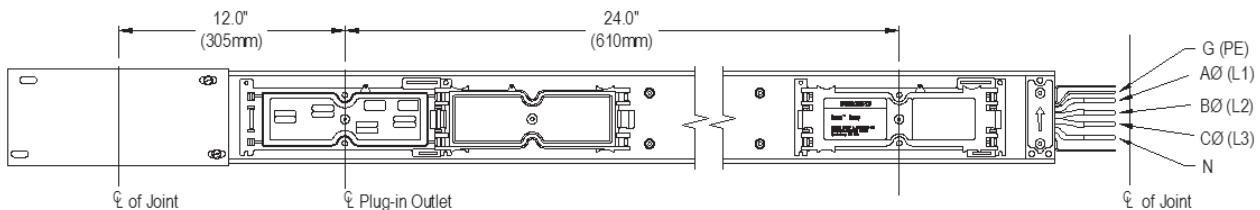

**Standard One-Sided Plug-In Section (Standard Plug-In outlets on one side on 24 in. centers)**  
Suffix RI04 (4 ft.), RI06 (6 ft.), RI08 (8 ft.), RI10 (10 ft.)

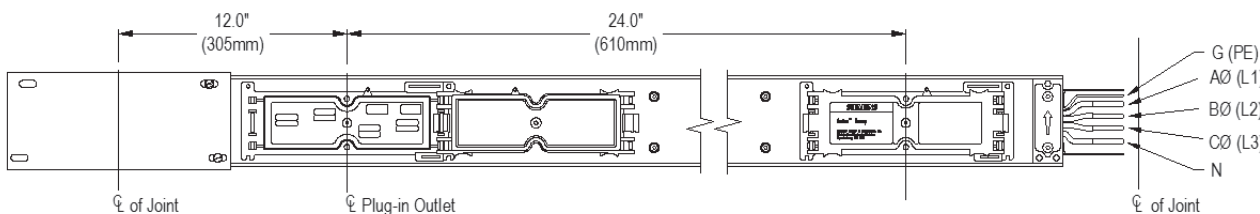

### Standard Feeder Section

Suffix F024 - 120 (last 3 digits = length in Inches, 015=15 in., 120=120 in.)

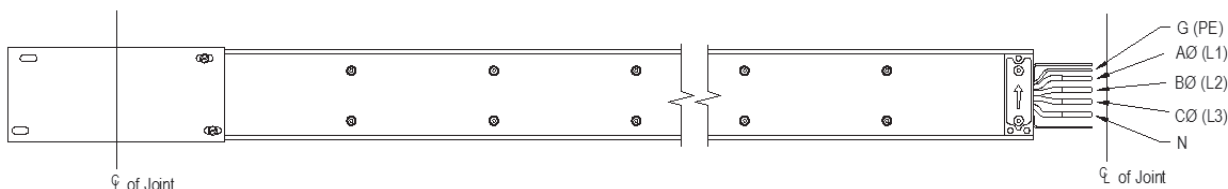



# Sentron Busway Systems

Selection

## Sentron Busway, Widths and Weights

Ampere Rating	Dimension Inches (mm)	Approximate Weight - lbs per ft. (kg per meter)						
		3Ø, 3-Wire	3Ø, 3-Wire with Internal Ground	3Ø, 4-Wire	3Ø, 4-Wire with Internal Ground	3Ø, 4-Wire 200% Neutral	3Ø, 4-Wire 200% Neutral with Internal Ground	
<b>AL L-Rated</b>								
225 —	"W1" 3.9 (99)	5 (8)	5 (8)	6 (9)	6 (9)	7 (10)	7 (10)	7 (10)
400 —	"W1" 3.9 (99)	5 (8)	5 (8)	6 (9)	6 (9)	7 (10)	7 (10)	7 (10)
600 —	"W1" 3.9 (99)	5 (8)	5 (8)	6 (9)	6 (9)	7 (10)	7 (10)	7 (10)
800 400	"W1" 4.6 (117)	6 (9)	6 (9)	7 (10)	7 (10)	7 (11)	8 (11)	8 (11)
1000 600	"W1" 5.4 (137)	7 (10)	7 (11)	8 (12)	8 (12)	9 (13)	9 (14)	9 (14)
1200 800	"W1" 6.6 (168)	8 (12)	9 (13)	9 (14)	10 (15)	11 (16)	11 (17)	11 (17)
1350 1000	"W1" 7.6 (193)	9 (13)	10 (15)	11 (16)	11 (17)	12 (18)	13 (19)	13 (19)
1600 1200	"W1" 8.7 (221)	10 (15)	11 (17)	12 (18)	13 (19)	14 (21)	15 (22)	15 (22)
2000 1250,1600	"W1" 10.9 (277)	13 (19)	14 (21)	15 (23)	16 (24)	18 (26)	19 (28)	19 (28)
2500 2000	"W2" 13.7 (348)	15 (22)	17 (25)	18 (27)	20 (30)	22 (33)	23 (34)	23 (34)
3000 2500	"W2" 15.8 (402)	17 (25)	19 (28)	21 (31)	23 (34)	25 (37)	27 (40)	27 (40)
3200 2000	"W2" 17.3 (439)	18 (27)	20 (30)	23 (34)	25 (37)	27 (40)	29 (43)	29 (43)
4000 3000,3200	"W2" 20.3 (516)	22 (33)	25 (37)	27 (40)	30 (44)	32 (48)	35 (52)	35 (52)
<b>CU M-Rated</b>								
225 —	"W1" 3.9 (99)	9 (13)	10 (14)	10 (16)	11 (17)	12 (18)	13 (19)	13 (19)
400 —	"W1" 3.9 (99)	9 (13)	10 (14)	10 (16)	11 (17)	12 (18)	13 (19)	13 (19)
600 —	"W1" 3.9 (99)	9 (13)	10 (14)	10 (16)	11 (17)	12 (18)	13 (19)	13 (19)
800 400	"W1" 3.9 (99)	9 (13)	10 (14)	10 (16)	11 (17)	12 (18)	13 (19)	13 (19)
1000 —	"W1" 4.4 (112)	10 (15)	11 (17)	12 (19)	14 (20)	15 (22)	16 (23)	16 (23)
1200 600	"W1" 5.1 (130)	12 (18)	14 (20)	15 (23)	16 (24)	18 (26)	19 (29)	19 (29)
1350 800	"W1" 5.7 (145)	14 (21)	16 (24)	17 (26)	19 (29)	21 (31)	23 (34)	23 (34)
1600 1000	"W1" 6.7 (170)	17 (26)	19 (29)	22 (32)	24 (35)	26 (38)	28 (42)	28 (42)
2000 1200,1350	"W1" 8.2 (208)	22 (32)	25 (37)	28 (41)	30 (45)	33 (50)	36 (54)	36 (54)
— 1600	"W1" 8.7 (221)	13 (19)	14 (21)	15 (23)	16 (24)	18 (26)	19 (28)	19 (28)
2500 2000	"W1" 10.7 (272)	30 (44)	34 (50)	38 (56)	42 (62)	46 (68)	50 (74)	50 (74)
3000 —	"W2" 11.8 (300)	33 (49)	37 (55)	42 (63)	47 (70)	51 (76)	56 (83)	56 (83)
3200 —	"W2" 13.3 (335)	37 (55)	42 (63)	48 (72)	53 (79)	58 (86)	64 (95)	64 (95)
4000 2500,3000,3200	"W2" 15.3 (389)	43 (64)	50 (75)	56 (83)	62 (92)	68 (101)	75 (112)	75 (112)
5000 4000	"W2" 19.3 (491)	56 (83)	64 (95)	72 (107)	80 (119)	89 (132)	97 (145)	97 (145)

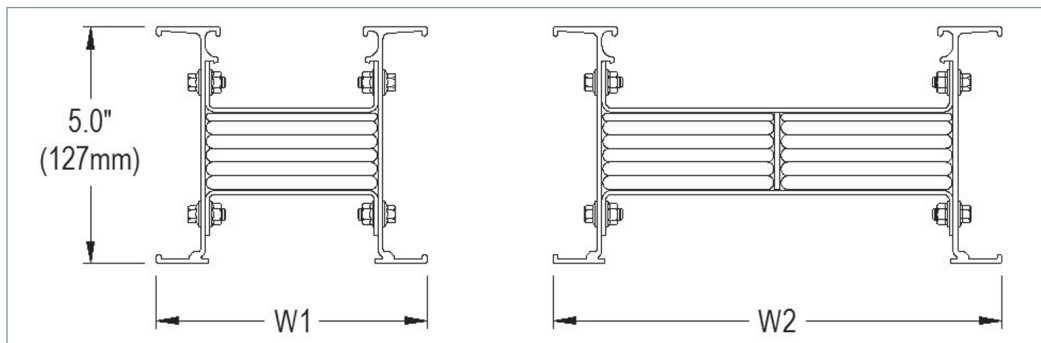

# Sentron Straight Section Busway

Copper (225-5000 Ampere) and Aluminum (225-4000 Ampere)

Selection

## Copper (225 - 5000Ampere)

Base Catalog Number Guide									
Ampere	3-Pole	3-Pole Internal Ground	3-Pole Isolated Ground	4-Pole	4-Pole 200% Neutral	4-Pole Internal Ground	4-Pole 200% Neutral Internal Ground	4-Pole Isolated Ground	4-Pole 200% Neutral Isolated Ground
225	SX302C1	SX302C2	SX302C3	SX402C1	SX502C1	SX402C2	SX502C2	SX402C3	SX502C3
400	SX304C1	SX304C2	SX304C3	SX404C1	SX504C1	SX404C2	SX504C2	SX404C3	SX504C3
600	SX306C1	SX306C2	SX306C3	SX406C1	SX506C1	SX406C2	SX506C2	SX406C3	SX506C3
800	SX308C1	SX308C2	SX308C3	SX408C1	SX508C1	SX408C2	SX508C2	SX408C3	SX508C3
1000	SX310C1	SX310C2	SX310C3	SX410C1	SX510C1	SX410C2	SX510C2	SX410C3	SX510C3
1200	SX312C1	SX312C2	SX312C3	SX412C1	SX512C1	SX412C2	SX512C2	SX412C3	SX512C3
1350	SX313C1	SX313C2	SX313C3	SX413C1	SX513C1	SX413C2	SX513C2	SX413C3	SX513C3
1600	SX316C1	SX316C2	SX316C3	SX416C1	SX516C1	SX416C2	SX516C2	SX416C3	SX516C3
2000	SX320C1	SX320C2	SX320C3	SX420C1	SX520C1	SX420C2	SX520C2	SX420C3	SX520C3
2500	SX325C1	SX325C2	SX325C3	SX425C1	SX525C1	SX425C2	SX525C2	SX425C3	SX525C3
3000	SX330C1	SX330C2	SX330C3	SX430C1	SX530C1	SX430C2	SX530C2	SX430C3	SX530C3
3200	SX332C1	SX332C2	SX332C3	SX432C1	SX532C1	SX432C2	SX532C2	SX432C3	SX532C3
4000	SX340C1	SX340C2	SX340C3	SX440C1	SX540C1	SX440C2	SX540C2	SX440C3	SX540C3
5000	SX350C1	SX350C2	SX350C3	SX450C1	SX550C1	SX450C2	SX550C2	SX450C3	SX550C3

## Aluminum (225 - 4000Ampere)

Base Catalog Number Guide									
Ampere	3-Pole	3-Pole Internal Ground	3-Pole Isolated Ground	4-Pole	4-Pole 200% Neutral	4-Pole Internal Ground	4-Pole 200% Neutral Internal Ground	4-Pole Isolated Ground	4-Pole 200% Neutral Isolated Ground
225	SX302A1	SX302A2	SX302A3	SX402A1	SX502A1	SX402A2	SX502A2	SX402A3	SX502A3
400	SX304A1	SX304A2	SX304A3	SX404A1	SX504A1	SX404A2	SX504A2	SX404A3	SX504A3
600	SX306A1	SX306A2	SX306A3	SX406A1	SX506A1	SX406A2	SX506A2	SX406A3	SX506A3
800	SX308A1	SX308A2	SX308A3	SX408A1	SX508A1	SX408A2	SX508A2	SX408A3	SX508A3
1000	SX310A1	SX310A2	SX310A3	SX410A1	SX510A1	SX410A2	SX510A2	SX410A3	SX510A3
1200	SX312A1	SX312A2	SX312A3	SX412A1	SX512A1	SX412A2	SX512A2	SX412A3	SX512A3
1350	SX313A1	SX313A2	SX313A3	SX413A1	SX513A1	SX413A2	SX513A2	SX413A3	SX513A3
1600	SX316A1	SX316A2	SX316A3	SX416A1	SX516A1	SX416A2	SX516A2	SX416A3	SX516A3
2000	SX320A1	SX320A2	SX320A3	SX420A1	SX520A1	SX420A2	SX520A2	SX420A3	SX520A3
2500	SX325A1	SX325A2	SX325A3	SX425A1	SX525A1	SX425A2	SX525A2	SX425A3	SX525A3
3000	SX330A1	SX330A2	SX330A3	SX430A1	SX530A1	SX430A2	SX530A2	SX430A3	SX530A3
3200	SX332A1	SX332A2	SX332A3	SX432A1	SX532A1	SX432A2	SX532A2	SX432A3	SX532A3
4000	SX340A1	SX340A2	SX340A3	SX440A1	SX540A1	SX440A2	SX540A2	SX440A3	SX540A3

## Suffix Numbers

Busway Type	Base Catalog Number Suffix			
	IP40	IP55	IP66	Nema 3R
Feeder	0F	4F	6F	9F
Plug-in	0P	4P	—	—
One-sided Plug-in	0R	4R	—	—

# Sentron Busway Systems

## Elbows

## Selection

Sentron Busway elbows provide a simple, convenient method of changing the direction (left, right, up or down) of a busway run. Two elbow styles are offered: elbow stack and elbow section.

Flatwise Elbow Stacks, Dimensions (standard/min.)		Dimensions Inches (mm) "A"
Ampere Rating		
<b>AL</b>	<b>L-Rated</b>	
225	—	1.00 (25)
400	—	1.00 (25)
600	—	1.00 (25)
800	400	1.12 (28)
1000	600	2.00 (51)
1200	800	2.50 (64)
1350	1000	3.00 (76)
1600	1200	3.50 (89)
2000	1350,1600	4.62 (117)
2500	2000	5.75 (146)
3000	2500	7.00 (178)
3200	2000	7.75 (197)
4000	3000,3200	9.35 (237)
<b>CU</b>	<b>M-Rated</b>	
225	—	1.00 (25)
400	—	1.00 (25)
600	—	1.00 (25)
800	400	1.00 (25)
1000	—	1.12 (28)
1200	600	1.25 (33)
1350	800	2.00 (50)
1600	1000	2.50 (64)
2000	1200,1350	3.25 (83)
—	1600	4.62 (117)
2500	2000	4.50 (114)
3000	—	5.00 (127)
3200	—	5.75 (146)
4000	2500,3000,3200	6.75 (171)
5000	4000	8.87 (225)

**Note:** Flatwise elbow stacks can be ordered as either right-hand (ESFR) or left-hand (ESFL) to follow the same nomenclature as an elbow section. The construction is identical and interchangeable.

### Flatwise Elbow Stacks

Flatwise elbow stacks are used for left and right directional changes when the busway system is mounted flatwise in the horizontal plane (bus bars run parallel to the floor).

#### Flat

#### Suffix ESFR/ESFL

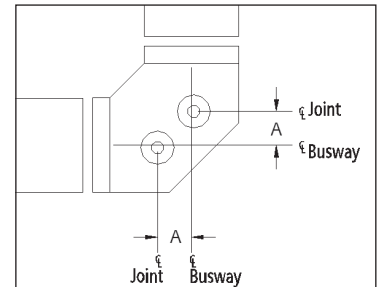
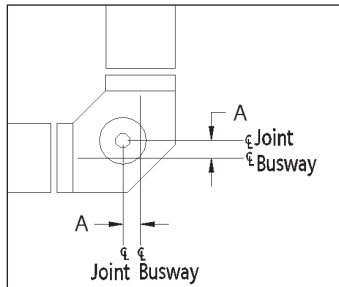
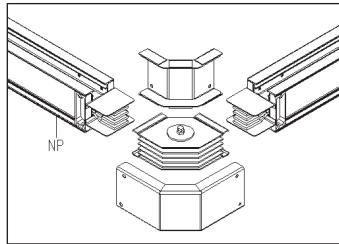

Edgewise Elbow Stacks, Dimensions (standard/min.)		Dimensions Inches (mm) "A"
Ampere Rating		
<b>AL</b>	<b>L-Rated</b>	
225	—	4.25 (108)
400	—	4.25 (108)
600	—	4.25 (108)
800	400	4.25 (108)
1000	600	4.25 (108)
1200	800	4.25 (108)
1350	1000	4.25 (108)
1600	1200	4.25 (108)
2000	1350,1600	4.25 (108)
2500	2000	4.25 (108)
3000	2500	4.25 (108)
3200	2000	4.25 (108)
<b>CU</b>	<b>M-Rated</b>	
225	—	4.25 (108)
400	—	4.25 (108)
600	—	4.25 (108)
800	400	4.25 (108)
1000	—	4.25 (108)
1200	600	4.25 (108)
1350	800	4.25 (108)
1600	1000	4.25 (108)
2000	1200,1350	4.25 (108)
—	1600	4.25 (108)
2500	2000	4.25 (108)
3000	—	4.25 (108)
3200	—	4.25 (108)
4000	2500,3000,3200	4.25 (108)
5000	4000	4.25 (108)

**Note:** Edge up and edge down elbow stacks are not interchangeable.

### Edgewise Elbow Stacks

Edgewise elbow stacks create up and down directional changes. The "A" phase is on the inside of the bend for edge up elbow stacks. The "A" phase is on the outside of the bend for edge down elbow stacks.

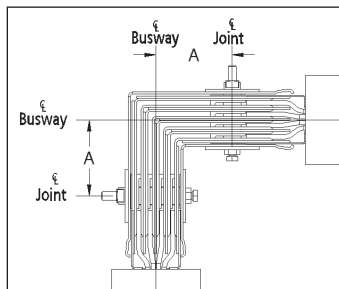

#### Edge Down

#### Suffix ESED

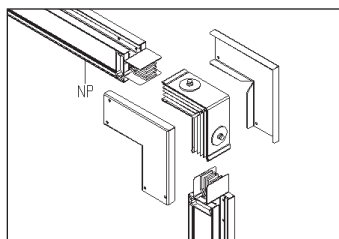

#### Edge Up

#### Suffix ESEU

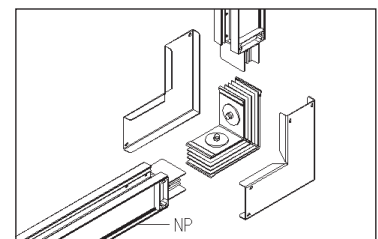

# Sentron Busway Systems

## Elbows

## Selection

Flatwise Elbow Sections, Dimensions (standard/min.)			
Ampere Rating		Dimensions Inches (mm)	
		"A"	"B"
<b>AL</b>	<b>L-Rated</b>		
225	—	12 (305)	12 (305)
400	—	12 (305)	12 (305)
600	—	12 (305)	12 (305)
800	400	12 (305)	12 (305)
1000	600	12(305)	12 (305)
1200	800	12 (305)	12 (305)
1350	1000	12 (305)	12 (305)
1600	1200	18 (457)	18 (457)
2000	1350,1600	18 (457)	18 (457)
2500	2000	18 (457)	18 (457)
3000	2500	18 (457)	18 (457)
3200	2000	18 (457)	18 (457)
4000	3000,3200	24 (610)	24 (610)
<b>CU</b>	<b>M-Rated</b>		
225	—	12 (305)	12 (305)
400	—	12 (305)	12 (305)
600	—	12 (305)	12 (305)
800	400	12 (305)	12 (305)
1000	—	12 (305)	12 (305)
1200	600	12 (305)	12 (305)
1350	800	12 (305)	12 (305)
1600	1000	12 (305)	12 (305)
2000	1200,1350	12 (305)	12 (305)
—	1600	18 (457)	18 (457)
2500	2000	18 (457)	18 (457)
3000	—	18 (457)	18 (457)
3200	—	18 (457)	18 (457)
4000	2500,3000,3200	18 (457)	18 (457)
5000	4000	24 (610)	24 (610)

Edgewise Elbow Sections, Dimensions (standard/min.)			
Ampere Rating		Dimensions Inches (mm)	
		"A"	"B"
<b>AL</b>	<b>L-Rated</b>		
225	—	10 (254)	10 (254)
400	—	10 (254)	10 (254)
600	—	10 (254)	10 (254)
800	400	10 (254)	10 (254)
1000	600	10 (254)	10 (254)
1200	800	10 (254)	10 (254)
1350	1000	10 (254)	10 (254)
1600	1200	10 (254)	10 (254)
2000	1350,1600	10 (254)	10 (254)
2500	2000	10 (254)	10 (254)
3000	2500	10 (254)	10 (254)
3200	2000	10 (254)	10 (254)
4000	3000,3200	10 (254)	10 (254)
<b>CU</b>	<b>M-Rated</b>		
225	—	10 (254)	10 (254)
400	—	10 (254)	10 (254)
600	—	10 (254)	10 (254)
800	400	10 (254)	10 (254)
1000	—	10 (254)	10 (254)
1200	600	10 (254)	10 (254)
1350	800	10 (254)	10 (254)
1600	1000	10 (254)	10 (254)
2000	1200,1350	10 (254)	10 (254)
—	1600	10 (254)	10 (254)
2500	2000	10 (254)	10 (254)
3000	—	10 (254)	10 (254)
3200	—	10 (254)	10 (254)
4000	2500,3000,3200	10 (254)	10 (254)
5000	4000	10 (254)	10 (254)

Note : Odd angle elbow flatwise and edgewise elbow sections are available for angles 95° - 175° in 5° increments.

### Flatwise Elbow Sections

Flatwise elbow sections are used for left and right directional changes when the busway system is mounted in the horizontal plane (bus bars run parallel to the floor). The joint stack assembly may be moved to the opposite leg to change the orientation from left to right/right to left.

#### Flat Left

##### Suffix ELFL

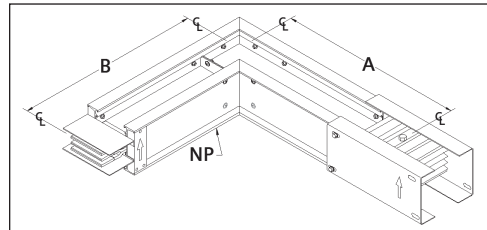

#### Flat Right

##### Suffix ELFR

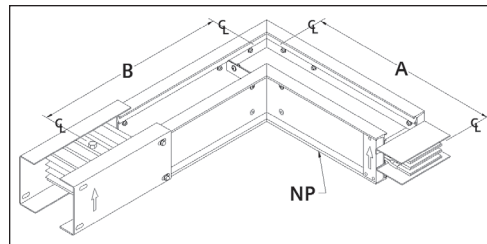

### Edgewise Elbow Sections

Edgewise elbow sections create up and down directional changes. The "A" phase bus bar lies on the inside of the bend for edge up elbows. The "A" phase bus bar lies on the outside of the bend for edge down elbows. The joint stack assembly on edgewise elbows can not be moved in order to change orientation from up to down/down to up. Sentron Busway elbow sections are shipped with a joint stack assembly on one end for direct connection to the busway system.

#### Edge Up

##### Suffix ELEU

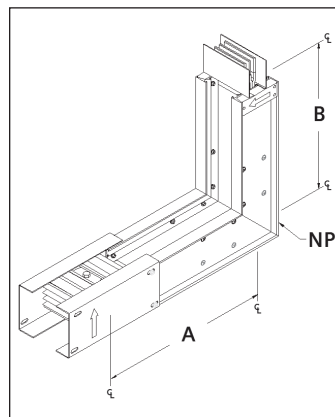

#### Edge Down

##### Suffix ELED

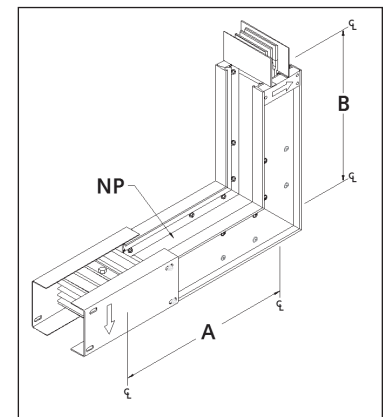

# Sentron Busway Systems

## Offsets

Selection

Offsets can be utilized to solve difficult contour problems and save space. In applications where space does not allow for two connected elbows, a single offset can bypass an obstruction. All offsets are supplied with one joint stack assembly.

Flatwise Offsets, Dimensions (standard/min.)				
Ampere Rating		Dimensions Inches (mm)		
		*"A"	"B"	"C"
<b>AL</b>	<b>L-Rated</b>			
225	—	12 (305)	5 (127)	12 (305)
400	—	12 (305)	5 (127)	12 (305)
600	—	12 (305)	5 (127)	12 (305)
800	400	12 (305)	5 (127)	12 (305)
1000	600	12 (305)	5 (127)	12 (305)
1200	800	12 (305)	5 (127)	12 (305)
1350	1000	12 (305)	5 (127)	12 (305)
1600	1200	18 (457)	5 (127)	18 (457)
2000	1350,1600	18 (457)	5 (127)	18 (457)
2500	2000	18 (457)	5 (127)	18 (457)
3000	2500	18 (457)	5 (127)	18 (457)
3200	2000	18 (457)	5 (127)	18 (457)
4000	3000,3200	24 (610)	8 (203)	24 (610)
<b>CU</b>	<b>M-Rated</b>			
225	—	12 (305)	5 (127)	12 (305)
400	—	12 (305)	5 (127)	12 (305)
600	—	12 (305)	5 (127)	12 (305)
800	400	12 (305)	5 (127)	12 (305)
1000	—	12 (305)	5 (127)	12 (305)
1200	600	12 (305)	5 (127)	12 (305)
1350	800	12 (305)	5 (127)	12 (305)
1600	1000	12 (305)	5 (127)	12 (305)
2000	1200,1350	12 (305)	5 (127)	12 (305)
—	1600			
2500	2000	18 (457)	5 (127)	18 (457)
3000	—	18 (457)	5 (127)	18 (457)
3200	—	18 (457)	5 (127)	18 (457)
4000	2500,3000,3200	18 (457)	5 (127)	18 (457)
5000	4000	24 (610)	8 (203)	24 (610)

### Flat Right

#### Suffix OFFR

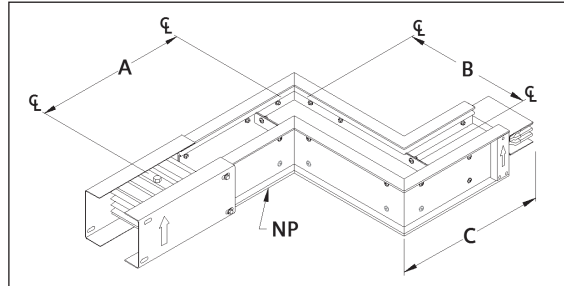

### Flat Left

#### Suffix OFFL

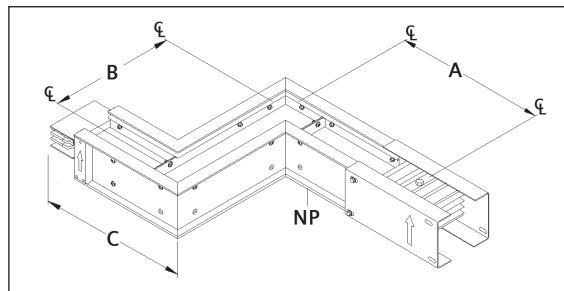

### Edge Up

#### Suffix OFEU

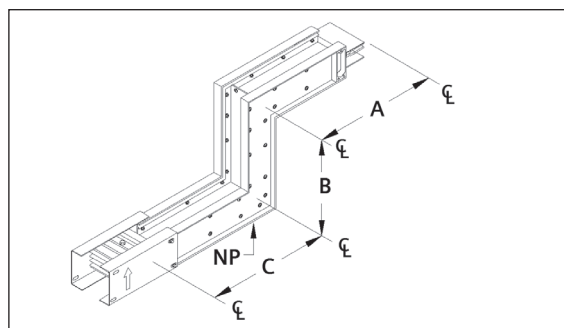

### Edge Down

#### Suffix OFED

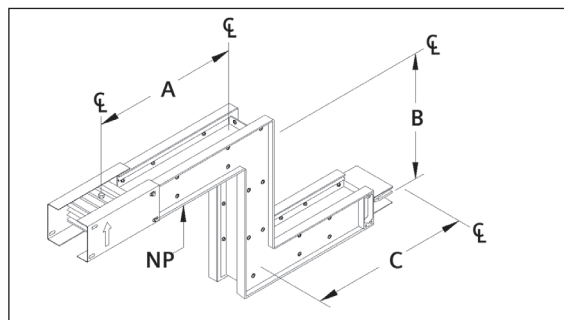

Edgewise Offsets, Dimensions (standard/min.)				
Ampere Rating		Dimensions Inches (mm)		
		*"A"	"B"	"C"
<b>AL</b>	<b>L-Rated</b>			
225	—	10 (254)	6 (152)	10 (254)
400	—	10 (254)	6 (152)	10 (254)
600	—	10 (254)	6 (152)	10 (254)
800	400	10 (254)	6 (152)	10 (254)
1000	600	10 (254)	6 (152)	10 (254)
1200	800	10 (254)	6 (152)	10 (254)
1350	1000	10 (254)	6 (152)	10 (254)
1600	1200	10 (254)	6 (152)	10 (254)
2000	1350,1600	10 (254)	6 (152)	10 (254)
2500	2000	10 (254)	6 (152)	10 (254)
3000	2500	10 (254)	6 (152)	10 (254)
3200	2000	10 (254)	6 (152)	10 (254)
4000	3000,3200	10 (254)	6 (152)	10 (254)
<b>CU</b>	<b>M-Rated</b>			
225	—	10 (254)	6 (152)	10 (254)
400	—	10 (254)	6 (152)	10 (254)
600	—	10 (254)	6 (152)	10 (254)
800	400	10 (254)	6 (152)	10 (254)
1000	—	10 (254)	6 (152)	10 (254)
1200	600	10 (254)	6 (152)	10 (254)
1350	800	10 (254)	6 (152)	10 (254)
1600	1000	10 (254)	6 (152)	10 (254)
2000	1200,1350	10 (254)	6 (152)	10 (254)
—	1600			
2500	2000	10 (254)	6 (152)	10 (254)
3000	—	10 (254)	6 (152)	10 (254)
3200	—	10 (254)	6 (152)	10 (254)
4000	2500,3000,3200	10 (254)	6 (152)	10 (254)
5000	4000	10 (254)	6 (152)	10 (254)

\*Note: Leg Dimensions A and C have been reversed from prior publications.



# Sentron Busway Systems

## Combinations

## Selection

Combinations are used to create edge to flat and flat to edge changes in the busway run. One joint stack assembly is shipped with combination.

See drawings for minimum dimensions. Consult Busway Order Service for information on custom lengths.

Combinations, Dimensions (standard/min.)		Dimensions Inches (mm)		
Ampere Rating		"A"	"B"	"C"
<b>AL</b>	<b>L-Rated</b>			
225	—	10 (254)	8 (203)	12 (305)
400	—	10 (254)	8 (203)	12 (305)
600	—	10 (254)	8 (203)	12 (305)
800	400	10 (254)	8 (203)	12 (305)
1000	600	10 (254)	8 (203)	12 (305)
1200	800	10 (254)	8 (203)	12 (305)
1350	1000	10 (254)	8 (203)	12 (305)
1600	1200	10 (254)	12 (305)	18 (457)
2000	1350,1600	10 (254)	12 (305)	18 (457)
2500	2000	10 (254)	12 (305)	18 (457)
3000	2500	10 (254)	12 (305)	18 (457)
3200	2000	10 (254)	12 (305)	18 (457)
4000	3000,3200	10 (254)	16 (406)	24 (610)
<b>CU</b>	<b>M-Rated</b>			
225	—	10 (254)	8 (203)	12 (305)
400	—	10 (254)	8 (203)	12 (305)
600	—	10 (254)	8 (203)	12 (305)
800	400	10 (254)	8 (203)	12 (305)
1000	—	10 (254)	8 (203)	12 (305)
1200	600	10 (254)	8 (203)	12 (305)
1350	800	10 (254)	8 (203)	12 (305)
1600	1000	10 (254)	8 (203)	12 (305)
2000	1200,1350	10 (254)	8 (203)	12 (305)
—	1600	10 (254)	12 (305)	18 (457)
2500	2000	10 (254)	12 (305)	18 (457)
3000	—	10 (254)	12 (305)	18 (457)
3200	—	10 (254)	12 (305)	18 (457)
4000	2500,3000,3200	10 (254)	12 (305)	18 (457)
5000	4000	10 (254)	16 (406)	24 (610)

\*Note: Leg Dimensions A and C have been reversed from prior publications.

**Flat Right - Edge Up**

**Suffix CORU**

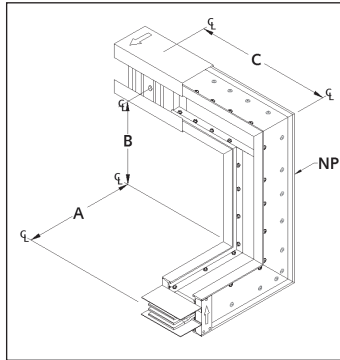

**Flat Left - Edge Up**

**Suffix COLU**

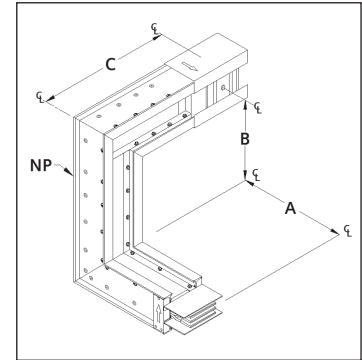

**Edge Up - Flat Left**

**Suffix COUL**

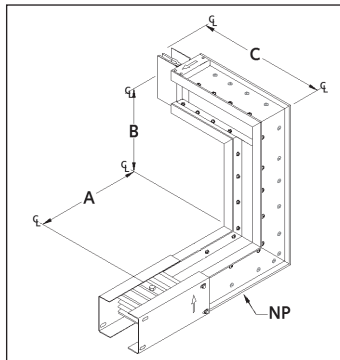

**Edge Up - Flat Right**

**Suffix COUR**

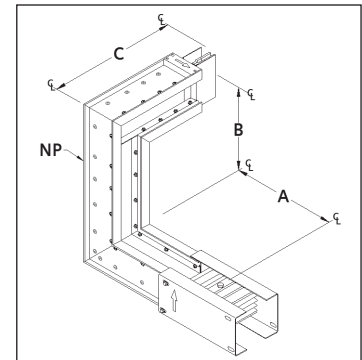

**Flat Right - Edge Down**

**Suffix CORD**

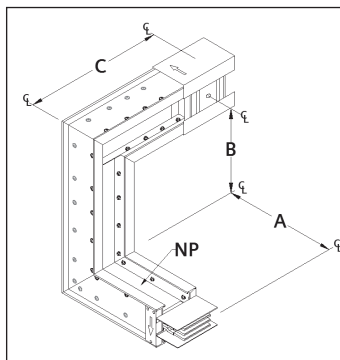

**Flat Left - Edge Down**

**Suffix COLD**

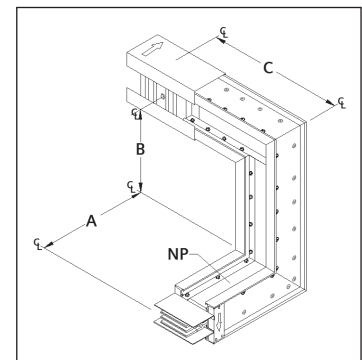

**Edge Down - Flat Left**

**Suffix CODL**

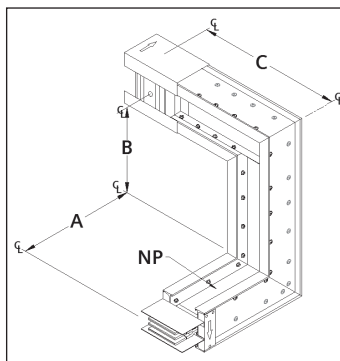

**Edge Down - Flat Right**

**Suffix CODR**

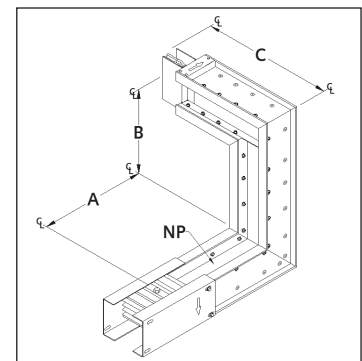

# Sentron Busway Systems

Tees

Selection

Tees are used to simplify directional and plane orientation changes in a busway system. Tees can make 90° bends left or right, and up and down along the busway run. All tees are supplied with two joint stack assemblies.

Flatwise Tees, Dimensions (standard/min.)		
Ampere Rating		Dimensions Inches (mm) "A", "B", "C"
<b>AL</b>	<b>L-Rated</b>	
225	—	12 (305)
400	—	12 (305)
600	—	12 (305)
800	400	12 (305)
1000	600	12 (305)
1200	800	12 (305)
1350	1000	12 (305)
1600	1200	18 (457)
2000	1350,1600	18 (457)
2500	2000	18 (457)
3000	2500	18 (457)
3200	2000	18 (457)
4000	3000,3200	24 (610)
<b>CU</b>	<b>M-Rated</b>	
225	—	12 (305)
400	—	12 (305)
600	—	12 (305)
800	400	12 (305)
1000	—	12 (305)
1200	600	12 (305)
1350	800	12 (305)
1600	1000	12 (305)
2000	1200,1350	12 (305)
—	1600	18 (457)
2500	2000	18 (457)
3000	—	18 (457)
3200	—	18 (457)
4000	2500,3000,3200	18 (457)
5000	4000	24 (610)

## Flatwise Tees

Flatwise tees are used to create left and right branches.

### Flat Right

#### Suffix TEFR

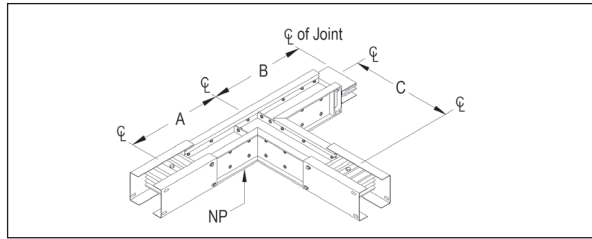

### Flat Left

#### Suffix TEFL

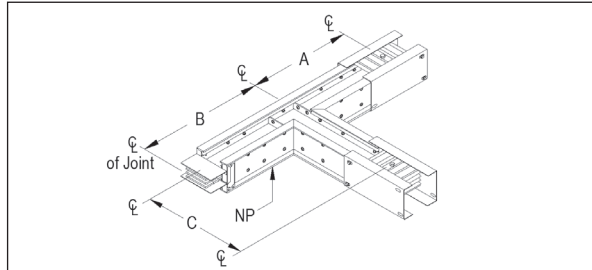

Edgewise Tees, Dimensions (standard/min.)		
Ampere Rating		Dimensions Inches (mm) "D"
<b>AL</b>	<b>L-Rated</b>	
225	—	13 (330)
400	—	13 (330)
600	—	13 (330)
800	400	13 (330)
1000	600	13 (330)
1200	800	18 (457)
1350	1000	18 (457)
1600	1200	18 (457)
2000	1350,1600	18 (457)
2500	2000	27 (686)
3000	2500	27 (686)
3200	2000	27 (686)
4000	3000,3200	29 (737)
<b>CU</b>	<b>M-Rated</b>	
225	—	13 (330)
400	—	13 (330)
600	—	13 (330)
800	400	13 (330)
1000	—	13 (330)
1200	600	13 (330)
1350	800	13 (330)
1600	1000	18 (457)
2000	1200,1350	18 (457)
—	1600	18 (457)
2500	2000	18 (457)
3000	—	27 (686)
3200	—	27 (686)
4000	2500,3000,3200	27 (686)
5000	4000	29 (737)

## Edgewise Tees

Edgewise tees are used to create branches that stem up or down from the busway run.

### Edge Up

#### Suffix TEEU

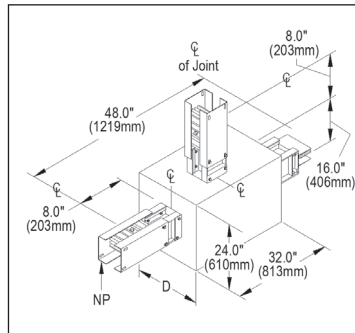

### Edge Down

#### Suffix TEED

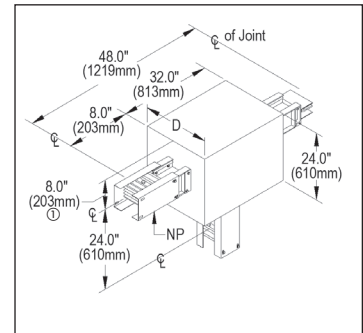

© 12.0" (305mm) For Isolated Ground.

# Sentron Busway Systems

## End Tap Boxes

## Selection

End tap boxes are non-fusible devices used to connect cable and conduit to the end of a busway run or where busway runs connect without the need for over-current protection. End tap boxes may be installed at the end or beginning of a run. Vertical end tap boxes and horizontal end tap boxes can be installed in both horizontal and vertical applications. Extended end tap boxes are available if the application requires additional wire bending space. One joint stack assembly is shipped with each end tap box.

Standard and Extended Horizontal End Tap Boxes, Dimensions								
Ampere Rating	Dimensions Inches (mm)			Wire Bend Space		Cable Lugs Per Phase & Neutral		Ground Lugs <sup>①</sup>
	"A"	"B" Std.	"B" Ext.	"C" Std.	"C" Ext.	Qty.	Size	
<b>AL L-Rated</b>								
225 —	13 (330)	30 (762)	34 (863)	17 (432)	21 (533)	1	①	1
400 —	13 (330)	30 (762)	34 (863)	17 (432)	21 (533)	1	②	1
600 —	13 (330)	30 (762)	34 (863)	17 (432)	21 (533)	2	②	1
800 400	13 (330)	30 (762)	34 (863)	17 (432)	21 (533)	3	②	1
1000 600	13 (330)	30 (762)	34 (863)	17 (432)	21 (533)	4	②	1
1200 800	18 (457)	33 (838)	37 (940)	20 (508)	24 (610)	4	②	1
1350 1000	18 (457)	33 (838)	37 (940)	20 (508)	24 (610)	4	②	1
1600 1200	18 (457)	33 (838)	37 (940)	20 (508)	24 (610)	5	②	1
2000 1350,1600	18 (457)	33 (838)	37 (940)	20 (508)	24 (610)	6	②	2
2500 2000	27 (686)	33 (838)	37 (940)	20 (508)	24 (610)	8	②	2
3000 2500	27 (686)	33 (838)	37 (940)	20 (508)	24 (610)	9	②	2
3200 2000	27 (686)	33 (838)	37 (940)	20 (508)	24 (610)	9	②	2
4000 3000,3200	29 (737)	33 (838)	37 (940)	20 (508)	24 (610)	12	②	3
<b>CU M-Rated</b>								
225 —	13 (330)	30 (762)	34 (863)	17 (432)	21 (533)	1	①	1
400 —	13 (330)	30 (762)	34 (863)	17 (432)	21 (533)	1	②	1
600 —	13 (330)	30 (762)	34 (863)	17 (432)	21 (533)	2	②	1
800 400	13 (330)	30 (762)	34 (863)	17 (432)	21 (533)	3	②	1
1000 —	13 (330)	30 (762)	34 (863)	17 (432)	21 (533)	4	②	1
1200 600	13 (330)	33 (838)	37 (940)	20 (508)	24 (610)	4	②	1
1350 800	13 (330)	33 (838)	37 (940)	20 (508)	24 (610)	4	②	1
1600 1000	18 (457)	33 (838)	37 (940)	20 (508)	24 (610)	5	②	1
2000 1200,1350	18 (457)	33 (838)	37 (940)	20 (508)	24 (610)	6	②	2
— 1600	18 (457)	33 (838)	37 (940)	20 (508)	24 (610)	5	②	1
2500 2000	18 (457)	33 (838)	37 (940)	20 (508)	24 (610)	8	②	2
3000 —	27 (686)	33 (838)	37 (940)	20 (508)	24 (610)	9	②	2
3200 —	27 (686)	33 (838)	37 (940)	20 (508)	24 (610)	9	②	2
4000 2500,3000,3200	27 (686)	33 (838)	37 (940)	20 (508)	24 (610)	12	②	3
5000 4000	29 (737)	33 (838)	37 (940)	20 (508)	24 (610)	15	②	4

### Horizontal End Tap Box

Suffix ETHS (Standard)  
Suffix ETHX (Extended)

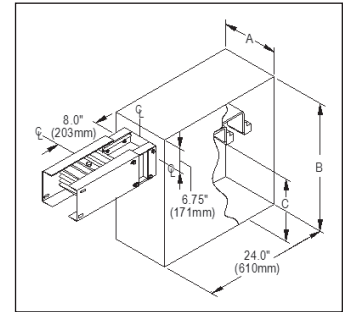

Standard and Extended Vertical End Tap Boxes, Dimensions								
Ampere Rating	Dimensions Inches (mm)			Wire Bend Space		Cable Lugs Per Phase & Neutral		Ground Lugs <sup>①</sup>
	"A"	"B" Std.	"B" Ext.	"C" Std.	"C" Ext.	Qty.	Size	
<b>AL L-Rated</b>								
225 —	13 (330)	25 (635)	29 (737)	17 (432)	21 (533)	1	①	1
400 —	13 (330)	25 (635)	29 (737)	17 (432)	21 (533)	1	②	1
600 —	13 (330)	25 (635)	29 (737)	17 (432)	21 (533)	2	②	1
800 400	13 (330)	25 (635)	29 (737)	17 (432)	21 (533)	3	②	1
1000 600	13 (330)	25 (635)	29 (737)	17 (432)	21 (533)	4	②	1
1200 800	18 (457)	28 (711)	32 (813)	20 (508)	24 (610)	4	②	1
1350 1000	18 (457)	28 (711)	32 (813)	20 (508)	24 (610)	4	②	1
1600 1200	18 (457)	28 (711)	32 (813)	20 (508)	24 (610)	5	②	1
2000 1350,1600	18 (457)	28 (711)	32 (813)	20 (508)	24 (610)	6	②	2
2500 2000	27 (686)	28 (711)	32 (813)	20 (508)	24 (610)	8	②	2
3000 2500	27 (686)	28 (711)	32 (813)	20 (508)	24 (610)	9	②	2
3200 2000	29 (737)	28 (711)	32 (813)	20 (508)	24 (610)	9	②	2
4000 3000,3200	29 (737)	28 (711)	32 (813)	20 (508)	24 (610)	12	②	3
<b>CU M-Rated</b>								
225 —	13 (330)	25 (635)	29 (737)	17 (432)	21 (533)	1	①	1
400 —	13 (330)	25 (635)	29 (737)	17 (432)	21 (533)	1	②	1
600 —	13 (330)	25 (635)	29 (737)	17 (432)	21 (533)	2	②	1
800 400	13 (330)	25 (635)	29 (737)	17 (432)	21 (533)	3	②	1
1000 —	13 (330)	25 (635)	29 (737)	17 (432)	21 (533)	4	②	1
1200 600	13 (330)	28 (711)	32 (813)	20 (508)	24 (610)	4	②	1
1350 800	13 (330)	28 (711)	32 (813)	20 (508)	24 (610)	4	②	1
1600 1000	18 (457)	28 (711)	32 (813)	20 (508)	24 (610)	5	②	1
2000 1200,1350	18 (457)	28 (711)	32 (813)	20 (508)	24 (610)	6	②	2
— 1600	18 (457)	28 (711)	32 (813)	20 (508)	24 (610)	5	②	1
2500 2000	18 (457)	28 (711)	32 (813)	20 (508)	24 (610)	8	②	2
3000 —	27 (686)	28 (711)	32 (813)	20 (508)	24 (610)	9	②	2
3200 —	27 (686)	28 (711)	32 (813)	20 (508)	24 (610)	9	②	2
4000 2500,3000,3200	27 (686)	28 (711)	32 (813)	20 (508)	24 (610)	12	②	3
5000 4000	29 (737)	28 (711)	32 (813)	20 (508)	24 (610)	15	②	4

### Vertical End Tap Box

Suffix ETVS (Standard)  
Suffix ETVX (Extended)

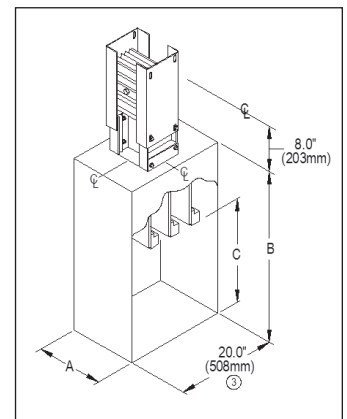

① #6 AWG -350 kcmil, Cu/Al.

② #4 AWG -600 kcmil, Cu/Al.

③ 24.0" (610mm) for isolated ground.

# Sentron Busway Systems

## Center Tap Boxes

Selection

Center tap boxes are non-fusible devices utilized to feed to or take off power from the busway run. When loads served by the busway run do not require over-current protection, center tap boxes may be used. If the application requires additional wiring bending space, extended center tap boxes are available. One joint stack assembly is provided with each center tap box.

Standard and Extended Center End Tap Boxes, Dimensions										
Ampere Rating	Dimensions Inches (mm)			Wire Bend Space			Cable Lugs Per Phase & Neutral		Ground Lugs <sup>①</sup>	
	"A" Std.	"B"	"D"	"A" Ext..	"C" Std.	"C" Ext.	Qty.	Size		
<b>AL L-Rated</b>										
225 —	25 (635)	16 (406)	3.9 (99)	29 (737)	17 (432)	21 (533)	1	①	1	
225 —	25 (635)	16 (406)	3.9 (99)	29 (737)	17 (432)	21 (533)	1	②	1	
400 —	25 (635)	16 (406)	3.9 (99)	29 (737)	17 (432)	21 (533)	1	②	1	
600 —	25 (635)	16 (406)	3.9 (99)	29 (737)	17 (432)	21 (533)	2	②	1	
800 400	25 (635)	16 (406)	4.2 (107)	29 (737)	17 (432)	21 (533)	3	②	1	
1000 600	25 (635)	16 (406)	4.6 (117)	29 (737)	17 (432)	21 (533)	4	②	1	
1200 800	29 (737)	16 (406)	5.2 (132)	33 (838)	20 (508)	24 (610)	4	②	1	
1350 1000	29 (737)	16 (406)	5.7 (145)	33 (838)	20 (508)	24 (610)	4	②	1	
1600 1200	33 (838)	20 (508)	6.3 (160)	37 (940)	20 (508)	24 (610)	5	②	1	
2000 1350,1600	33 (838)	20 (508)	7.4 (188)	37 (940)	20 (508)	24 (610)	6	②	2	
2500 2000	37 (940)	24 (610)	8.7 (221)	41 (1041)	20 (508)	24 (610)	8	②	2	
3000 2500	37 (940)	24 (610)	9.7 (246)	41 (1041)	20 (508)	24 (610)	9	②	2	
3200 2000	37 (940)	24 (610)	9.7 (246)	41 (1041)	20 (508)	24 (610)	9	②	2	
4000 3000,3200	45 (1143)	28 (711)	11.9 (302)	49 (1245)	20 (508)	24 (610)	12	②	3	
<b>CU M-Rated</b>										
225 —	25 (635)	16 (406)	3.9 (99)	29 (737)	17 (432)	21 (533)	1	②	1	
400 —	25 (635)	16 (406)	3.9 (99)	29 (737)	17 (432)	21 (533)	1	②	1	
600 —	25 (635)	16 (406)	3.9 (99)	29 (737)	17 (432)	21 (533)	2	②	1	
800 400	25 (635)	16 (406)	3.9 (99)	29 (737)	17 (432)	21 (533)	3	②	1	
1000 —	25 (635)	16 (406)	4.2 (107)	29 (737)	18 (457)	22 (559)	4	②	1	
1200 600	29 (737)	16 (406)	4.5 (114)	33 (838)	22 (559)	26 (660)	4	②	1	
1350 800	29 (737)	16 (406)	4.8 (122)	33 (838)	21 (533)	25 (635)	4	②	1	
1600 1000	29 (737)	20 (508)	5.3 (135)	33 (838)	21 (533)	25 (635)	5	②	1	
2000 1200,1350	29 (737)	20 (508)	6.1 (155)	33 (838)	20 (508)	24 (610)	6	②	2	
— 1600	33 (838)	20 (508)	6.3 (160)	37 (940)	20 (508)	24 (610)	5	②	1	
2500 2000	33 (838)	24 (610)	7.3 (185)	37 (940)	23 (584)	17 (432)	8	②	2	
3000 —	33 (838)	24 (610)	7.9 (201)	37 (940)	20 (508)	24 (610)	9	②	2	
3200 —	33 (838)	24 (610)	7.9 (201)	37 (940)	20 (508)	24 (610)	9	②	2	
4000 2500,3000,3200	37 (940)	28 (711)	9.4 (239)	41 (1041)	20 (508)	24 (610)	12	②	3	
5000 4000	40(1016)	34 (863)	11.7(297)	44 (1118)	19 (483)	23 (584)	15	②	4	

### Center Tap Box

Suffix CTBS (Standard)

Suffix CTBX (Extended)

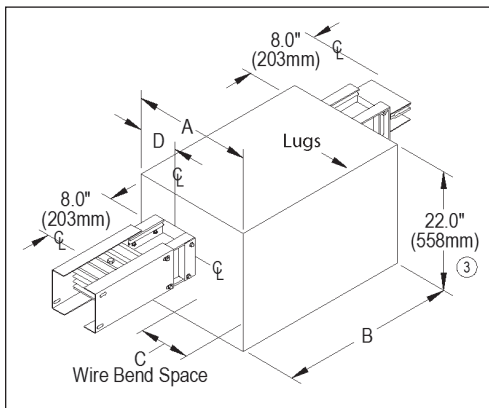

① #6 AWG -350 kcmil, Cu/Al.  
 ② #4 AWG -600 kcmil, Cu/Al.  
 ③ 24.0" (610mm) for isolated ground.

# Sentron Busway Systems

## Joint Mounted Tap Boxes

Selection

The joint mounted tap box (JMTB) is used to tap off power via the busway joint. This device does not provide over-current protection and therefore, must be installed in compliance with

NEC 240.21(B)<sup>Ⓞ</sup>. The small footprint is ideal for space limited applications. The JMTB is compatible with Power Mod, Lighting Panels, Power Panels, and Switchboards 1200A and lower.

### Horizontal Orientation JMTB

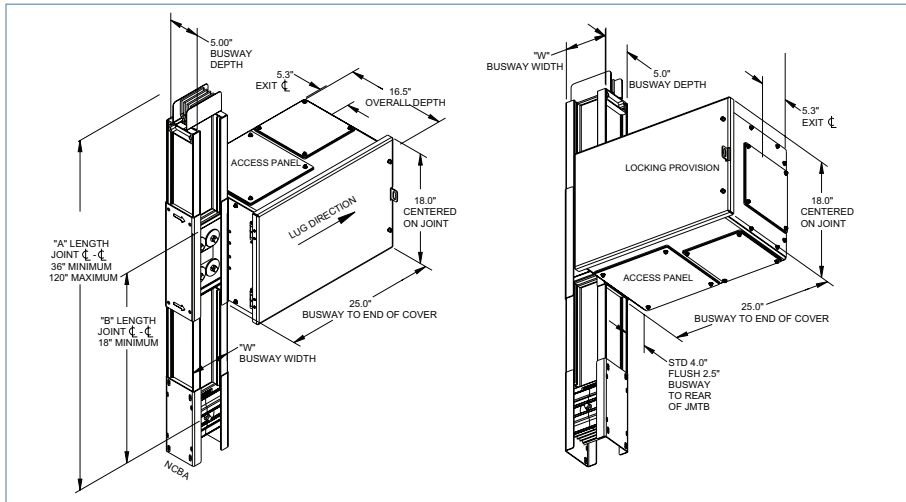

### Vertical Orientation JMTB

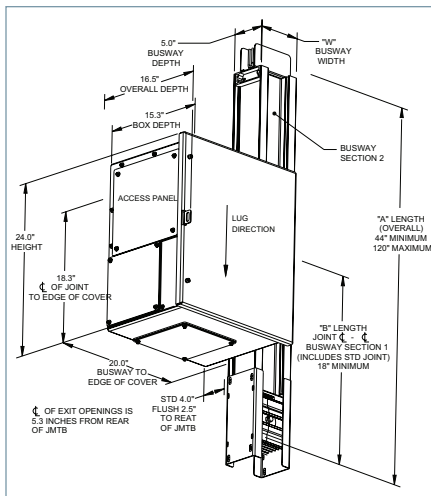

### Configuration Types

Given a vertical bus run, the JMTB can be configured such that it is on the Left, Right, or Both sides. The JMTB is shipped from the factory installed on the busway.

When installed on vertical busway, the lug orientation matches the orientation of the tap box. If using the horizontal JMTB the lug orientation will be left/right, if vertical JMTB it will be up/down.

The standard JMTB extends 4\"/>

### Product Features

- Lug Orientation: Vertical or Horizontal
- Maximum Voltage: 600V
- Maximum UL Short Circuit Rating: 150kA<sup>Ⓜ</sup>
- Amperage Range: 100- 1200A
- Lug Type: Compression Only

### Compression Lugs

The JMTB requires compression lugs, which aid in minimizing product size. The JMTB is shipped with UL listed crimp type compression lugs, which are sized to the amperage of the load side device.

Should additional lugs be required, please reference the table below. The JMTB utilizes general purpose aluminum 2 hole NEMA lugs, compatible with Aluminum and Copper wire. Homac AL-N series or equivalent are recommended.<sup>Ⓜ</sup>

If housing ground is selected the JMTB will contain a standard 4-hole NEMA pattern on a dedicated ground bar. If internal/isolated ground is selected, two ground bars will be included, each with the standard NEMA 4-hole pattern.

### Compression Lugs

Wire size	Straight Lug Catalog Number	Stacking Lug Catalog Number
1/0	AL1/0-NTN	ASL1/0-NTN
2/0	AL2/0-NTN	ASL2/0-NTN
3/0	AL3/0-NTN	ASL3/0-NTN
4/0	AL4/0-NTN	ASL4/0-NTN
250	AL250-NTN	ASL250-NTN
300	AL300-NTN	ASL300-NTN
350	AL350-NTN	ASL350-NTN

<sup>Ⓞ</sup> This device requires compliance with NEC 240.21(B), see 2017 NEC, commonly referred to as the 10ft feeder tap rule. Feeder tap conductors cannot be over 10ft

without overcurrent protection. Main circuit protection device is required downstream. Please reference the NEC before using this device.

<sup>Ⓜ</sup> For series ratings reference the UL short circuit table in the Technical Data section.

<sup>Ⓝ</sup> Replacement lugs to be supplied by others.



# Sentron Busway Systems

TBNK Fittings for Joint Mounted Tap Boxes **NEW**

Selection

## TBNK flexible fittings

TBNK flexible fittings are a UL listed, factory installed series of wireway couplings for use with Sentron Joint Mounted Tap Boxes (JMTB's). TBNK fittings provide a nominal 4.25" long flexible wireway for coupling the JMTB and rigidly mounted downstream equipment. TBNK fittings allow for expansion and contraction of the Busway absorbing up to an inch of movement. Available in 4, 6, and 8-inch sizes, TBNK fittings are suitable for a wide range of equipment amperages and cabling requirements. TBNK fittings if desired should be selected when ordering Sentron JMTB's.

## Installation and Grounding

TBNK flexible fittings must be field installed onto downstream equipment. JMTB's ordered with TBNK fittings include Installation Instructions and a template for making the required cut-out in the downstream equipment enclosure. Location of equipment, cut out and cabling must comply with applicable standards including NEC, Local Building Codes and any other authorities having jurisdiction. Consult codes in advance to assure compliance. The JMTB is shipped from the factory with a braided copper ground cable riveted onto the TBNK. During installation, the opposite end of the ground cable must be connected to the enclosure of the downstream equipment. The Installation Instructions provide details of the ground cable installation procedure.

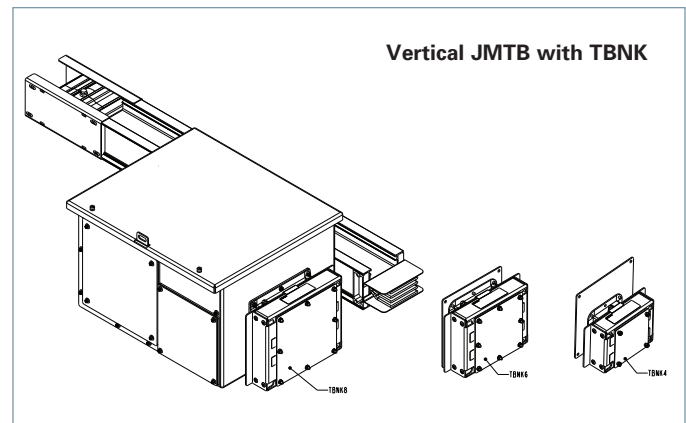
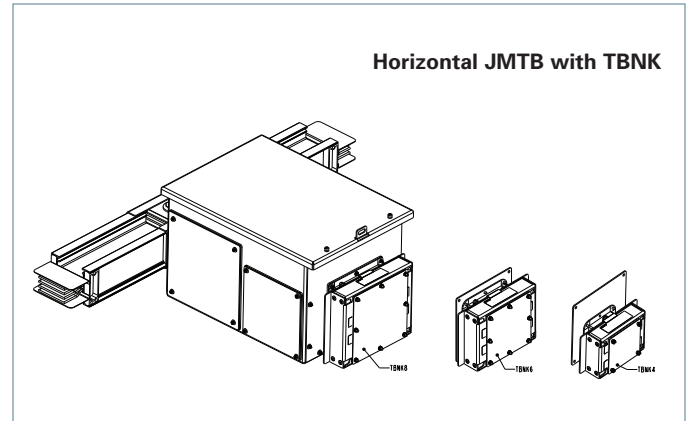

## TBNK flexible fittings

Catalog Number	Cutout Size	Wireway Size	Maximum Cable Size
TBNK4	3.8" x 3.8"	4" x 4" (16 sq. inch)	900MCM
TBNK6	5.8" x 5.8"	6" x 6" (36 sq. inch)	500MCM
TBNK8	7.8" x 7.8"	8" x 8" (64 sq. inch)	4/0

# Sentron Busway Systems

TBNK Fittings for Joint Mounted Tap Boxes **NEW**

Technical data

## TBNK4, TBNK6 and TBNK8

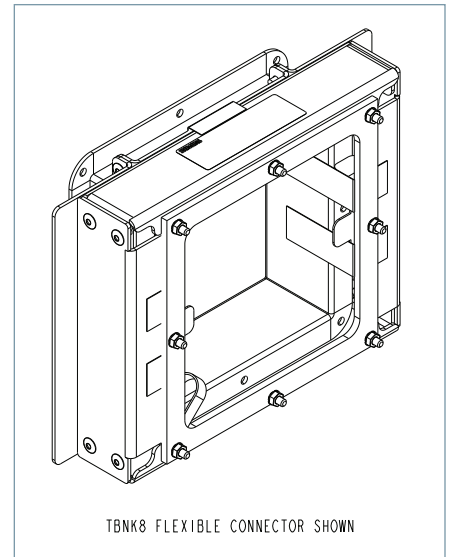
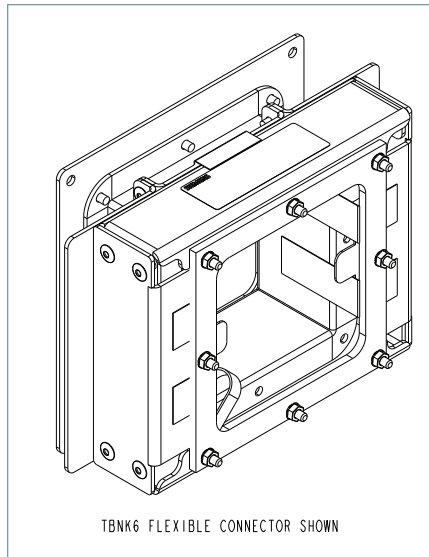
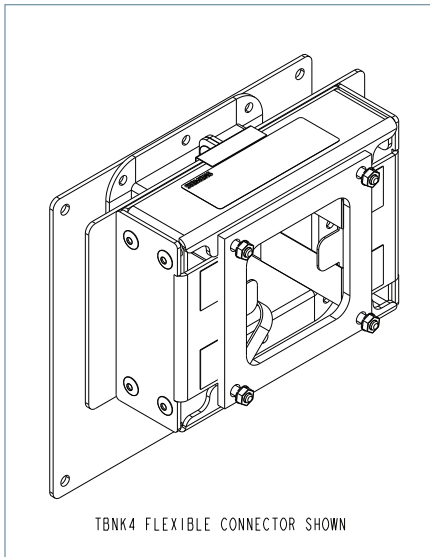

## TBNK cut out pattern

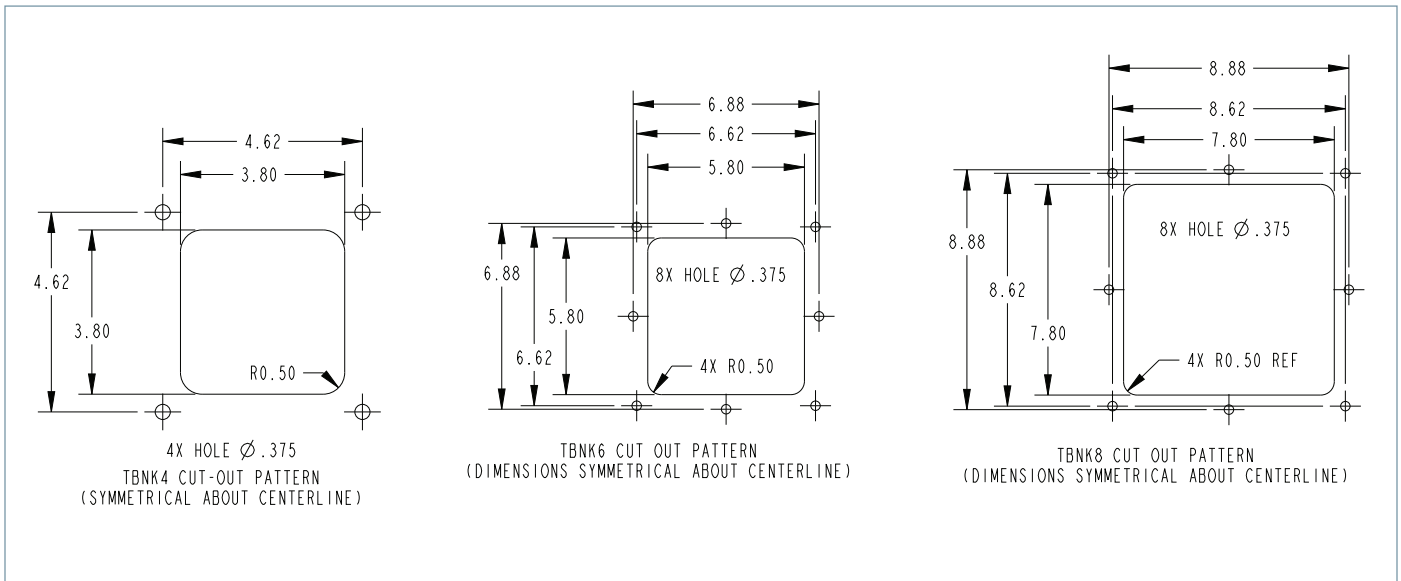

# Sentron Busway Systems

## Expansion Fittings

Selection

Expansion Fittings, Dimensions (standard/min.)		
Ampere Rating		Dimensions Inches (mm) "A"
<b>AL</b>	<b>L-Rated</b>	
225	—	13 (330)
400	—	13 (330)
600	—	13 (330)
800	400	13 (330)
1000	600	13 (330)
1200	800	18 (457)
1350	1000	18 (457)
1600	1200	18 (457)
2000	1350,1600	18 (457)
2500	2000	23 (584)
3000	2500	23 (584)
3200	2000	25 (635)
4000	3000,3200	25 (635)
<b>CU</b>	<b>M-Rated</b>	
225	—	13 (330)
400	—	13 (330)
600	—	13 (330)
800	400	13 (330)
1000	—	13 (330)
1200	600	13 (330)
1350	800	13 (330)
1600	1000	18 (457)
2000	1200,1350	18 (457)
—	1600	18 (457)
2500	2000	18 (457)
3000	—	23 (584)
3200	—	23 (584)
4000	2500,3000,3200	23 (584)
5000	4000	25 (635)

### Expansion Fittings

Expansion fittings accommodate for expansion and contraction of a busway run and building movement. Expansion fittings typically are installed in the center of long busway runs, and at the beginning of riser runs (within the first 20ft of vertical busway when total vertical run length is equal to or greater than 40ft) to minimize stress on the lower most device or where a busway run crosses an expansion joint of a building.

Qty (1) Expansion Section should be used for every 200ft of continuous Busway run length, at every transition to a vertical run, and at each building expansion joint. The Busway run must be positioned accordingly to accommodate the Expansion Section(s).

#### Expansion Fitting

##### Suffix XPFT

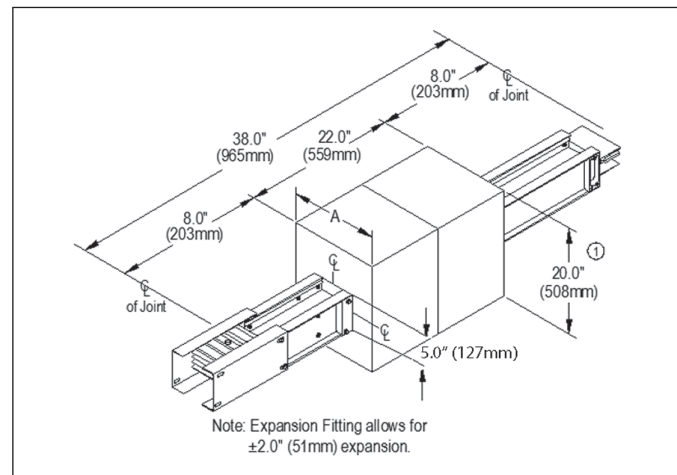

### Flush Mount Expansion Fitting

Often useful in riser application, flush mount expansion fittings allow for the busway to be positioned closer to building walls (reference page 15-36 for minimum required clearances). The flush mount design shifts the centerline of the busway up or down by 5 in. on the 20 in. height axis shown above.

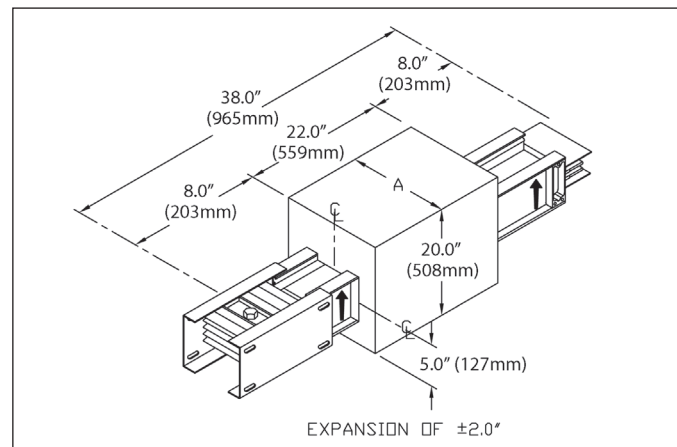

© 24.0\" (610mm) for isolated ground.

# Sentron Busway Systems

## Reducers and Phase Rotation Fittings

Selection

### Fused Reducers, Dimensions (standard/min)

X1 Ampere Rating		Dimensions A Inches (mm)		
		DIM B = 20.00		DIM B = 24.00
AL	L-Rated	X2 < 2000	3200 > X2 ≥ 2000	X2 ≥ 3200
225	—	10.5 (267)	—	—
400	—	10.5 (267)	—	—
600	—	10.5 (267)	—	—
800	400	10.5 (267)	—	—
1000	600	10.5 (267)	—	—
1200	800	10.5 (267)	—	—
1350	1000	15.0 (381)	—	—
1600	1200	15.0 (381)	—	—
2000	1350,1600	15.0 (381)	—	—
2500	2000	20.0 (508)	25.0 (635)	—
3000	2500	20.0 (508)	25.0 (635)	—
3200	—	25.0 (635)	30.0 (762)	—
4000	3000,3200	25.0 (635)	30.0 (762)	30.0 (762)
CU	M-Rated	X2 < 2000	3200 > X2 ≥ 2000	X2 ≥ 3200
225	—	10.5 (267)	—	—
400	—	10.5 (267)	—	—
600	—	10.5 (267)	—	—
800	225, 400	10.5 (267)	—	—
1000	—	10.5 (267)	—	—
1200	600	10.5 (267)	—	—
1350	800	10.5 (267)	—	—
1600	1000	10.5 (267)	—	—
2000	1200, 1350	15.0 (381)	—	—
—	1600	15.0 (381)	—	—
2500	2000	15.0 (381)	20.0 (508)	—
3000	—	20.0 (508)	25.0 (635)	—
3200	—	20.0 (508)	25.0 (635)	—
4000	2500, 3000, 3200	20.0 (508)	25.0 (635)	30.0 (762)
5000	4000	25.0 (635)	30.0 (762)	30.0 (762)

Notes: X1 is the Initial Amperage Stub. X2 is the Reduced Amperage Stub.  
 IF X2 = 3200A or 4000A, the Box height will need to be increased from 20.00" to 24.00" due to the 3500A+ Fuses have a diameter of 5.75"

### Fused Reducers

The National Electric Code requires over current protection when busway systems are reduced in ampacity. A fused reducer is used to reduce the allowable ampere rating in those sections of the busway that do not require a higher rating (i.e. at branch circuit junctures).

#### Fused Reducer – Class L Size Fuses

##### Suffix RFRF

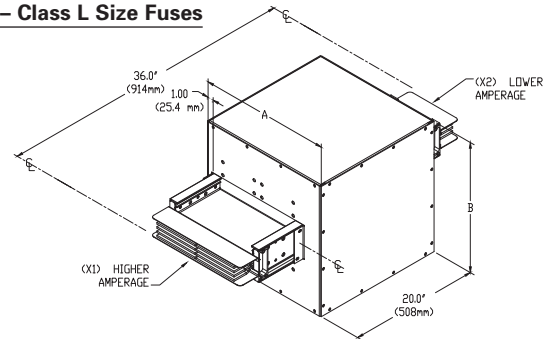

#### Non-Fused Reducers

Non-fused reducers are used in conjunction with the following exception to the Fused Reducer in the National Electric Code: "For industrial establishments only, omission of over current protection shall be permitted at points where busways are reduced in ampacity, provided that the length of the busway having the smaller ampacity does not exceed 50 ft. and has an ampacity of at least equal to one-third the rating or setting of the over current device next back on the line, and provided that such busway is free from contact with combustible material." Special joint stack connections are provided for non-fused reducer connections. Consult factory for specific design guidelines.

### 180 Degrees Phase Rotation Fittings, Dimensions (std/min.)

Ampere Rating		Dimensions A Inches (mm)
AL	L-Rated	
225	—	7.9 (200)
400	—	7.9 (200)
600	—	7.9 (200)
800	400	8.5 (216)
1000	600	9.4 (239)
1200	800	10.5 (267)
1350	1000	11.5 (293)
1600	1200	12.6 (321)
2000	1350, 1600	14.9 (376)
2500	2000	17.6 (447)
3000	2500	19.8 (503)
3200	2000	21.3 (541)
4000	3000, 3200	24.3 (617)
CU	M-Rated	
225	—	7.9 (200)
400	—	7.9 (200)
600	—	7.9 (200)
800	400	7.9 (200)
1000	—	8.4 (213)
1200	600	9.0 (229)
1350	800	9.6 (245)
1600	1000	10.6 (270)
2000	1200, 1350	12.1 (372)
—	1600	12.6 (321)
2500	2000	14.6 (200)
3000	—	15.8 (402)
3200	—	17.3 (439)
4000	2500, 3000, 3200	19.3 (490)
5000	4000	23.3 (592)

### 90 Degrees Phase Rotation Fittings, Dimensions (std/min.)

Ampere Rating		Dimensions A Inches (mm)
AL	L-Rated	
225	—	17 (432)
400	225	
600	—	
800	400	
1000	600	20 (508)
1200	800	
1350	1000	
1600	1200	
2000	1350, 1600	24 (610)
2500	2000	
3000	2500	
3200	—	
4000	3000	34 (863)
—	—	
—	—	
—	—	
CU	M-Rated	
225	—	17 (432)
400	—	
600	225 & 400	
800	—	
1000	—	20 (508)
1200	600	
1350	800	
1600	1000	
2000	1200, 1350	24 (610)
—	1600	
2500	2000	
3000	—	
3200	—	28 (711)
—	—	
—	—	
—	—	
4000	2500, 3000, 3200	34 (863)
5000	4000	

### Phase-Rotation Fittings

Phase-rotation fittings can be used when the application requires a phase rotation in the power supply. Phase rotation fittings can be ordered for "phase and ground", "phase only" and "ground only" rotations.

#### Phase Rotation Fitting

- Suffix TRPG, Phase and Ground
- TRPO, Phase Only
- TRGO, Ground Only

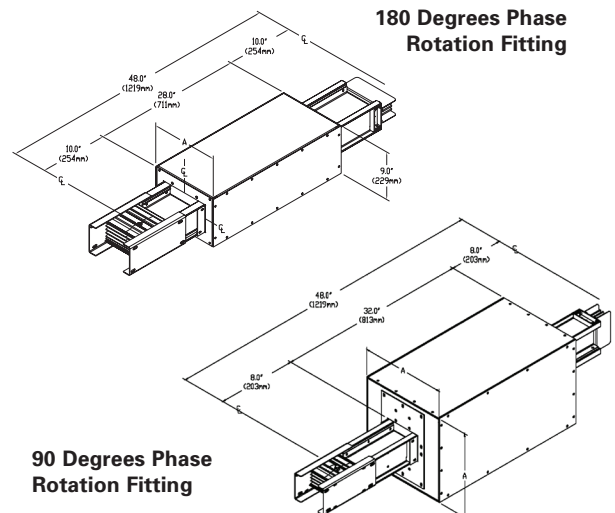

# Sentron Busway Systems

## Service Heads

## Selection

Service Heads are used to connect busway to a service entrance. In the Sentron Busway line, 3 single-phase service heads and 3-phase service head connections are available. The standard service entrance connection is the 3-phase service head which consists of one service head for all three phases. 3 single-phase service heads consist of three heads – one for each phase and may be used to meet the requirements of certain applications. To ensure ease of installation of incoming cables, both types of Sentron service heads are constructed so that the lugs face the Glastic bottom of the box. The Glastic bottom provides insulation and protection to the incoming cables.

Single-Phase Service Heads, Dimensions (standard/min.)						
Ampere Rating		Dimensions Inches (mm)		Cable Lugs per Phase and Neutral		Ground Lugs <sup>①</sup>
		Single-Phase "A"		Qty.	Size	
<b>AL L-Rated</b>						
225		13 (330)		1	①	1
400	225	13 (330)		1	②	1
600	—	13 (330)		2	②	1
800	400	13 (330)		3	②	1
1000	600	13 (330)		4	②	1
1200	800	18 (457)		4	②	1
1350	1000	18 (457)		4	②	1
1600	1200	18 (457)		5	②	1
2000	1350,1600	20 (508)		6	②	2
2500	2000	27 (686)		8	②	2
3000	2500	29 (737)		9	②	2
3200	2000	29 (737)		9	②	2
4000	3000,3200	29 (737)		12	②	3
<b>CU M-Rated</b>						
225		13 (330)		1	①	1
400		13 (330)		1	②	1
600		13 (330)		2	②	1
800	400	13 (330)		3	②	1
1000	—	13 (330)		4	②	1
1200	600	13 (330)		4	②	1
1350	800	13 (330)		4	②	1
1600	1000	18 (457)		5	②	1
2000	1200,1350	20 (508)		6	②	2
—	1600	18 (457)		5	②	1
2500	2000	20 (508)		8	②	2
3000	—	27 (686)		9	②	2
3200	—	27 (686)		9	②	2
4000	2500,3000,3200	27 (686)		12	②	3
5000	4000	29 (737)		15	②	4

### Three Single-Phase Service Heads Suffix V1TX

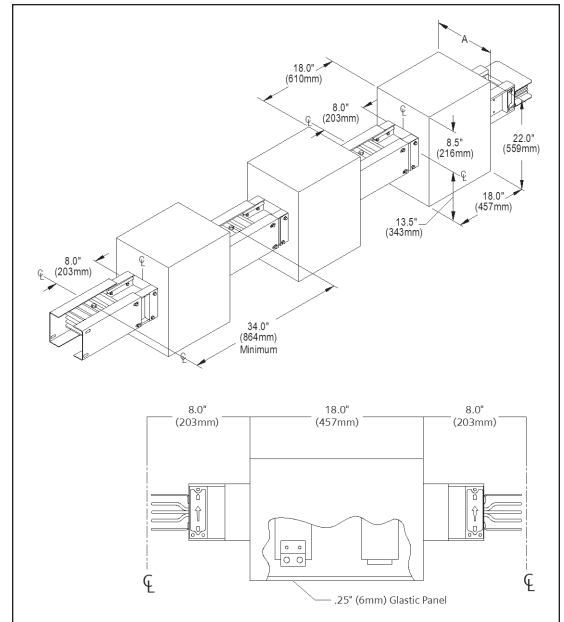

Three-Phase Service Heads, Dimensions (standard/min.)						
Ampere Rating		Dimensions Inches (mm)		Cable Lugs per Phase and Neutral		Ground Lugs <sup>①</sup>
		Three-Phase "B"		Qty.	Size	
<b>AL L-Rated</b>						
225		13 (330)		1	①	1
400	225	13 (330)		1	②	1
600	—	13 (330)		2	②	1
800	400	13 (330)		3	②	1
1000	600	13 (330)		4	②	1
1200	800	18 (457)		4	②	1
1350	1000	18 (457)		4	②	1
1600	1200	18 (457)		5	②	1
2000	1350,1600	18 (457)		6	②	2
2500	2000	27 (686)		8	②	2
3000	2500	27 (686)		9	②	2
3200	2000	27 (686)		9	②	2
4000	3000,3200	29 (737)		12	②	3
<b>CU M-Rated</b>						
225		13 (330)		1	①	1
400		13 (330)		1	②	1
600		13 (330)		2	②	1
800	400	13 (330)		3	②	1
1000	—	13 (330)		4	②	1
1200	600	13 (330)		4	②	1
1350	800	13 (330)		4	②	1
1600	1000	18 (457)		5	②	1
2000	1200,1350	18 (457)		6	②	2
—	1600	18 (457)		5	②	1
2500	2000	18 (457)		8	②	2
3000	—	27 (686)		9	②	2
3200	—	27 (686)		9	②	2
4000	2500,3000,3200	27 (686)		12	②	3
5000	4000	29 (737)		15	②	4

### Three-Phase Service Head Suffix V3TX

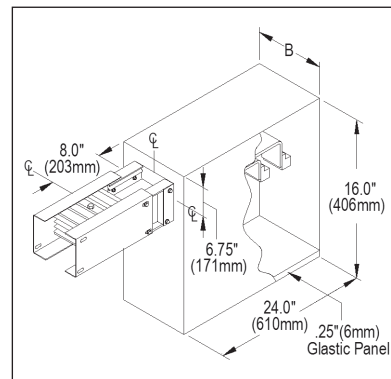

① #6 AWG - 350 kcmil, Cu / Al.

② #4 AWG - 600 kcmil, Cu / Al.



# Sentron Busway Systems

## Hangers

## Selection

### Trapeze Hanger—Aluminum (AL) and Copper (CU)

Ampere Rating		"A" Dimensions		Flat Mounted
		Inches (mm)		Catalog Number <sup>①</sup>
<b>AL</b>	<b>L-Rated</b>			
225	—	10.0 (254)		<b>SXTH1</b>
400	—	10.0 (254)		<b>SXTH1</b>
600	—	10.0 (254)		<b>SXTH1</b>
800	400	10.0 (254)		<b>SXTH1</b>
1000	600	10.0 (254)		<b>SXTH1</b>
1200	800	10.0 (254)		<b>SXTH1</b>
1350	1000	13.5 (343)		<b>SXTH2</b>
1600	1200	13.5 (343)		<b>SXTH2</b>
2000	1350,1600	13.5 (343)		<b>SXTH2</b>
2500	2000	13.5 (343)		<b>SXTH3</b>
3000	2500	13.5 (343)		<b>SXTH3</b>
3200	2000	13.5 (343)		<b>SXTH3</b>
4000	3000,3200	23.0 (584)		<b>SXTH4</b>
<b>CU</b>	<b>M-Rated</b>			
225	—	10.0 (254)		<b>SXTH1</b>
400	—	10.0 (254)		<b>SXTH1</b>
600	—	10.0 (254)		<b>SXTH1</b>
800	400	10.0 (254)		<b>SXTH1</b>
1000	—	10.0 (254)		<b>SXTH1</b>
1200	600	10.0 (254)		<b>SXTH1</b>
1350	800	10.0 (254)		<b>SXTH1</b>
1600	1000	10.0 (254)		<b>SXTH1</b>
2000	1200,1350	13.5 (343)		<b>SXTH2</b>
—	1600	13.5 (343)		<b>SXTH2</b>
2500	2000	13.5 (343)		<b>SXTH2</b>
3000	—	18.5 (470)		<b>SXTH3</b>
3200	—	18.5 (470)		<b>SXTH3</b>
4000	2500,3000,3200	18.5 (470)		<b>SXTH3</b>
5000	4000	23.0 (584)		<b>SXTH4</b>

① Use SXTH1 for Edge Mounted.

### Spring Hanger—Aluminum (AL) and Copper (CU)<sup>②</sup>

Ampere Rating		Floor to Ceiling Height (ft.)				
		10	12	14	16	18
<b>AL</b>	<b>L-Rated</b>					
225	—	SXSH4	SXSH4	SXSH4	SXSH4	SXSH4
400	—	SXSH4	SXSH4	SXSH4	SXSH4	SXSH4
600	—	SXSH4	SXSH4	SXSH4	SXSH4	SXSH4
800	400	SXSH4	SXSH4	SXSH4	SXSH6	SXSH6
1000	600	SXSH4	SXSH4	SXSH4	SXSH6	SXSH6
1200	800	SXSH4	SXSH4	SXSH4	SXSH6	SXSH6
1350	1000	SXSH4	SXSH4	SXSH6	SXSH6	SXSH6
1600	1200	SXSH8	SXSH8	SXSH8	SXSH8	SXSH8
2000	1350,1600	SXSH8	SXSH8	SXSH8	SXSH8	SXSH8
2500	2000	SXSH8	SXSH8	SXSH8	SXSH10	SXSH10
3000	2500	SXSH8	SXSH8	SXSH10	SXSH10	SXSH10
3200	2000	SXSH8	SXSH8	SXSH10	SXSH10	SXSH10
4000	3000,3200	SXSH8	SXSH10	SXSH10	SXSH10	SXSH12
<b>CU</b>	<b>M-Rated</b>					
225	—	SXSH4	SXSH4	SXSH4	SXSH4	SXSH4
400	—	SXSH4	SXSH4	SXSH4	SXSH4	SXSH4
600	—	SXSH4	SXSH4	SXSH4	SXSH4	SXSH4
800	400	SXSH4	SXSH4	SXSH6	SXSH6	SXSH6
1000	—	SXSH4	SXSH6	SXSH6	SXSH6	SXSH8
1200	600	SXSH6	SXSH6	SXSH6	SXSH8	SXSH8
1350	800	SXSH6	SXSH6	SXSH6	SXSH8	SXSH8
1600	1000	SXSH8	SXSH8	SXSH10	SXSH10	SXSH10
2000	1200,1350	SXSH8	SXSH10	SXSH10	SXSH10	SXSH12
2500	2000	SXSH10	SXSH12	SXSH12	SXSH12	SXSH14
3000	—	SXSH10	SXSH12	SXSH12	SXSH14	SXSH14
3200	—	SXSH12	SXSH12	SXSH14	SXSH14	SXSH12A
4000	2500,3000,3200	SXSH12	SXSH14	SXSH14	SXSH16	SXSH14A
5000	4000	SXSH14	SXSH12A	SXSH14A	SXSH16A	SXSH16B

② Assuming 3P4W busway with no additional busway-supported weight per floor. This information is confirmed during the quotation process, for additional information please contact your local Siemens Sales representative.

### Trapeze Hanger

A complete offering of hangers is available to support Sentron Busway in both vertical and horizontal applications. Standard trapeze hangers support Sentron Busway in horizontal applications on 10 ft. (3.05m) centers. Additional hangers may be used if structural requirements mandate their use. The contractor must supply drop rods to complete assembly for trapeze hangers.

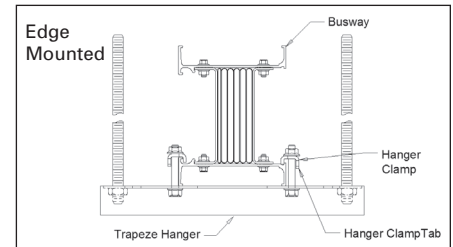
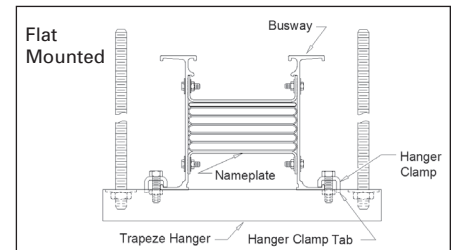
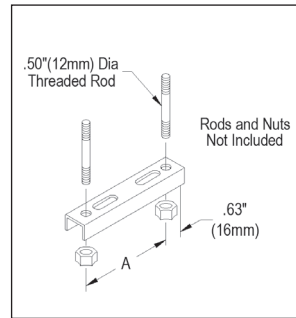

Watch the Busway Support installation video



### Spring Hanger

Spring hangers and floor support hangers must be used to provide secure mounting of the busway run in vertical applications. Spring hangers support the weight of the busway on each floor and also compensate for minimal building movement and thermal expansion. Maximum distance between spring hangers may not exceed 16 ft. (4.88m). When ordering 18 ft. (5.49m) floor to ceiling height assemblies, intermediate support hangers are necessary.

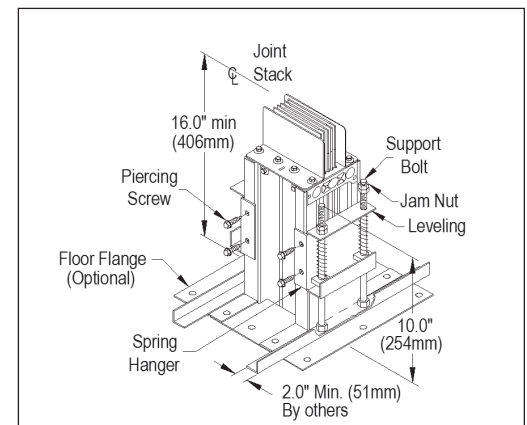

\*Note: Flanges do not offer support to the busway. Flanges provide a means of covering the hole created in the existing structure.

# Sentron Busway Systems

## Hangers

Selection

Structural Steel Hanger, Dimensions and Catalog Numbers			
Ampere Rating		"A" Dimensions Inches (mm)	Catalog Number
<b>AL</b>	<b>L-Rated</b>		
225	—	10.0 (254)	<b>SXSS1</b>
400	—	10.0 (254)	<b>SXSS1</b>
600	—	10.0 (254)	<b>SXSS1</b>
800	400	10.0 (254)	<b>SXSS1</b>
1000	600	10.0 (254)	<b>SXSS1</b>
1200	800	10.0 (254)	<b>SXSS1</b>
1350	1000	13.5 (343)	<b>SXSS2</b>
1600	1200	13.5 (343)	<b>SXSS2</b>
2000	1350,1600	13.5 (343)	<b>SXSS2</b>
2500	2000	18.5 (470)	<b>SXSS3</b>
3000	2500	18.5 (470)	<b>SXSS3</b>
3200	2000	18.5 (470)	<b>SXSS3</b>
4000	3000,3200	23.0 (584)	<b>SXSS4</b>
<b>CU</b>	<b>M-Rated</b>		
225	—	10.0 (254)	<b>SXSS1</b>
400	—	10.0 (254)	<b>SXSS1</b>
600	—	10.0 (254)	<b>SXSS1</b>
800	400	10.0 (254)	<b>SXSS1</b>
1000	—	10.0 (254)	<b>SXSS1</b>
1200	600	10.0 (254)	<b>SXSS1</b>
1350	800	10.0 (254)	<b>SXSS1</b>
1600	1000	10.0 (254)	<b>SXSS1</b>
2000	1200,1350	13.5 (343)	<b>SXSS2</b>
—	1600	13.5 (343)	<b>SXSS2</b>
2500	2000	13.5 (343)	<b>SXSS2</b>
3000	—	13.5 (343)	<b>SXSS2</b>
3200	—	13.5 (343)	<b>SXSS2</b>
4000	2500,3000,3200	13.5 (343)	<b>SXSS2</b>
5000	4000	23.0 (584)	<b>SXSS4</b>

### Structural Steel Hanger

A complete offering of hangers is available to support Sentron Busway in both vertical and horizontal applications. Structural Steel hangers support Sentron Busway in horizontal applications on 10 ft. (3.05m) centers. Additional hangers may be used if structural requirements mandate their use.

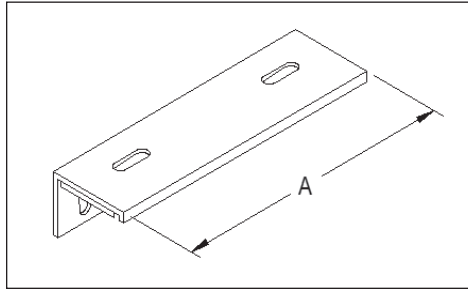

Single Drop Rod Hanger, Catalog Numbers		
Ampere Rating		Catalog Number
<b>AL</b>	<b>L-Rated</b>	
225	—	<b>SXDRA1</b>
400	—	<b>SXDRA1</b>
600	—	<b>SXDRA1</b>
800	400	<b>SXDRA2</b>
1000	600	<b>SXDRA3</b>
1200	800	<b>SXDRA4</b>
1350	1000	<b>SXDRA5</b>
1600	1200	<b>SXDRA6</b>
2000	1350,1600	<b>SXDRA7</b>
2500	2000	—
3000	2500	—
3200	2000	—
4000	3000,3200	—
<b>CU</b>	<b>M-Rated</b>	
225	—	<b>SXDRC1</b>
400	—	<b>SXDRC1</b>
600	—	<b>SXDRC1</b>
800	400	<b>SXDRC1</b>
1000	—	<b>SXDRC2</b>
1200	600	<b>SXDRC3</b>
1350	800	<b>SXDRC4</b>
1600	1000	<b>SXDRC5</b>
2000	1200,1350	<b>SXDRC6</b>
—	1600	<b>SXDRC6</b>
2500	2000	<b>SXDRC7</b>
3000	—	—
3200	—	—
4000	2500,3000,3200	—
5000	4000	—

### Single Drop Rod Hanger

A complete offering of hangers is available to support Sentron Busway in both vertical and horizontal applications. Single drop rod hangers support Sentron Busway in horizontal applications on 10 ft. (3.05m) centers. Additional hangers may be used if structural requirements mandate their use. The contractor must supply drop rods to complete assembly for single drop rod hangers.

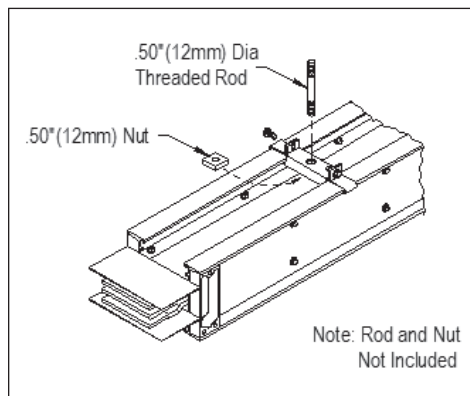

Note: Drop rod hangers can only be used when phase arrows are pointing up.

Wall Mounted Hanger, Dimensions and Catalog Numbers					
Ampere Rating		Dimensions Inches (mm)			Catalog Number
		"A"	"B"	"C"	
<b>AL</b>	<b>L-Rated</b>				
225	—	12.3 (311)	6.1 (156)	4.2 (107)	<b>SXWH1</b>
400	—	12.3 (311)	6.1 (156)	4.2 (107)	<b>SXWH1</b>
600	—	12.3 (311)	6.1 (156)	4.2 (107)	<b>SXWH1</b>
800	400	12.3 (311)	6.1 (156)	3.8 (97)	<b>SXWH1</b>
1000	600	12.3 (311)	6.1 (156)	3.8 (97)	<b>SXWH1</b>
1200	800	12.3 (311)	6.1 (156)	2.8 (72)	<b>SXWH1</b>
1350	1000	16.3 (413)	8.1 (206)	4.4 (111)	<b>SXWH2</b>
1600	1200	16.3 (413)	8.1 (206)	3.9 (98)	<b>SXWH2</b>
2000	1350,1600	16.3 (413)	8.1 (206)	2.8 (70)	<b>SXWH2</b>
2500	2000	20.8 (527)	10.4 (264)	3.6 (92)	<b>SXWH3</b>
3000	2500	20.8 (527)	10.4 (264)	2.5 (64)	<b>SXWH3</b>
3200	2000	20.8 (527)	10.4 (264)	1.8 (46)	<b>SXWH3</b>
4000	3000,3200	25.3 (641)	12.6 (321)	2.5 (64)	<b>SXWH4</b>
<b>CU</b>	<b>M-Rated</b>				
225	—	12.3 (311)	6.1 (156)	4.2 (107)	<b>SXWH1</b>
400	—	12.3 (311)	6.1 (156)	4.2 (107)	<b>SXWH1</b>
600	—	12.3 (311)	6.1 (156)	4.2 (107)	<b>SXWH1</b>
800	400	12.3 (311)	6.1 (156)	3.8 (97)	<b>SXWH1</b>
1000	—	12.3 (311)	6.1 (156)	3.8 (97)	<b>SXWH1</b>
1200	600	12.3 (311)	6.1 (156)	2.8 (72)	<b>SXWH1</b>
1350	800	12.3 (311)	6.1 (156)	2.8 (72)	<b>SXWH1</b>
1600	1000	12.3 (311)	6.1 (156)	2.8 (72)	<b>SXWH1</b>
2000	1200,1350	16.3 (413)	8.1 (206)	4.4 (111)	<b>SXWH2</b>
—	1600	16.3 (413)	8.1 (206)	3.9 (98)	<b>SXWH2</b>
2500	2000	16.3 (413)	8.1 (206)	2.8 (70)	<b>SXWH2</b>
3000	—	20.8 (527)	10.4 (264)	3.6 (92)	<b>SXWH3</b>
3200	—	20.8 (527)	10.4 (264)	2.5 (64)	<b>SXWH3</b>
4000	2500,3000,3200	20.8 (527)	10.4 (264)	1.8 (46)	<b>SXWH3</b>
5000	4000	25.3 (641)	12.6 (321)	2.5 (64)	<b>SXWH4</b>

### Wall Mounted Hanger

Wall Mounted Hangers are used for horizontal applications close to a wall. The busway can be mounted either edgewise or flatwise to the wall.

Wall Mounted Hanger ensures the minimum clearance between the wall and the busway run.

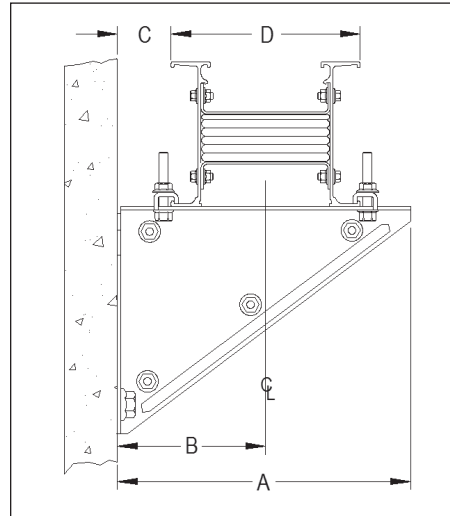

### End Closers

End closers safely terminate a busway run and protect the bus bar ends. End closers may be removed easily in order to extend a busway run. End closers are shipped with Glastic insulation pieces, however, joint stacks and inspection covers are not included.

#### End Closers

(Joint stack and covers not included)

Suffix ECLS

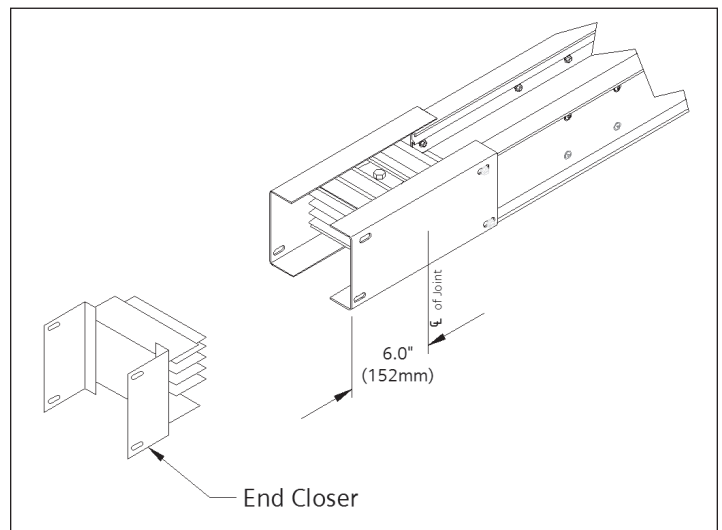

# Sentron Busway Systems

## Roof, Wall, Ceiling and Floor Flanges

Selection

Roof, wall, ceiling and floor flanges are available for Sentron Busway. When the busway run passes through a roof, wall or ceiling, a flange should be used. Flanges do not offer support to the busway. Flanges provide a means of covering the hole

created in the existing structure. Additional sealant may be required to meet fire codes and all other local requirements. No caulking or gasketing is provided with Sentron flanges.

Roof Flanges, Dimensions		Dimensions Inches (mm)	
Ampere Rating		"A"	"B"
<b>AL</b>	<b>L-Rated</b>		
225	—	12 (305)	18 (457)
400	—	12 (305)	18 (457)
600	—	12 (305)	18 (457)
800	400	12 (305)	18 (457)
1000	600	12 (305)	18 (457)
1200	800	12 (305)	18 (457)
1350	1000	16 (406)	22 (559)
1600	1200	16 (406)	22 (559)
2000	1350,1600	16 (406)	22 (559)
2500	2000	20.5 (521)	22 (559)
3000	2500	20.5 (521)	26.5 (673)
3200	2000	20.5 (521)	26.5 (673)
4000	3000,3200	25 (635)	31 (787)
<b>CU</b>	<b>M-Rated</b>		
225	—	12 (305)	18 (457)
400	—	12 (305)	18 (457)
600	—	12 (305)	18 (457)
800	400	12 (305)	18 (457)
1000	—	12 (305)	18 (457)
1200	600	12 (305)	18 (457)
1350	800	12 (305)	18 (457)
1600	1000	12 (305)	18 (457)
2000	1200,1350	16 (406)	22 (559)
—	1600	16 (406)	22 (559)
2500	2000	16 (406)	22 (559)
3000	—	20.5 (521)	26.5 (673)
3200	—	20.5 (521)	26.5 (673)
4000	2500,3000,3200	20.5 (521)	26.5 (673)
5000	4000	25 (635)	31 (787)

### Roof Flanges

Roof flanges are available for Sentron Busway. When the busway run passes through a roof, a flange should be used. Flanges do not offer support to the busway. Flanges provide a means of covering the hole created in the existing structure. Additional sealant may be required to meet fire codes and all other local requirements. No caulking or gasketing is provided with Sentron flanges. Roof flanges provide a watertight seal for use with NEMA 3R and IP66 rated busway. Roof pitch must be indicated on drawings when ordering roof flanges.

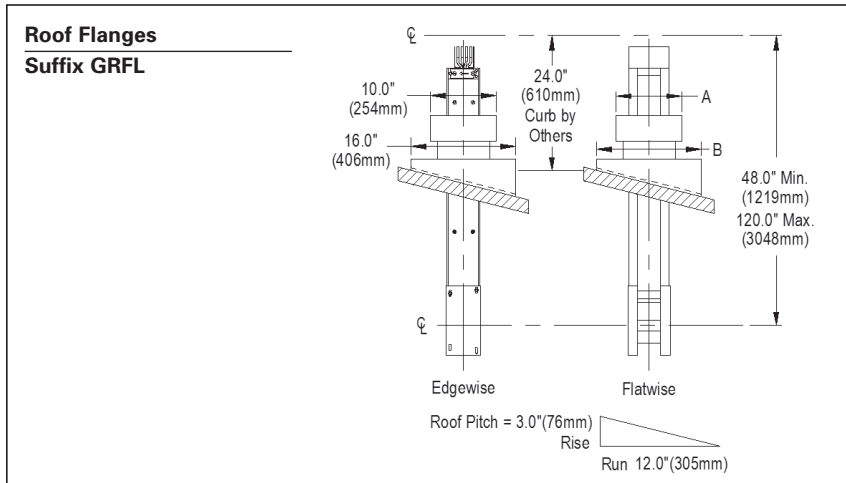

BUSWAY SYSTEMS 15

Wall, Ceiling and Floor Flanges, Dimensions		Dimensions Inches (mm)	
Ampere Rating		"A"	"B"
<b>AL</b>	<b>L-Rated</b>		
225	—	11 (279)	7 (178)
400	—	11 (279)	7 (178)
600	—	11 (279)	7 (178)
800	400	11 (279)	7 (178)
1000	600	12 (305)	8 (203)
1200	800	13 (330)	9 (229)
1350	1000	14 (356)	10 (254)
1600	1200	15 (381)	11 (279)
2000	1350,1600	17 (432)	13 (330)
2500	2000	20 (508)	16 (406)
3000	2500	22 (559)	18 (457)
3200	2000	24 (610)	20 (508)
4000	3000,3200	26 (660)	22 (559)
<b>CU</b>	<b>M-Rated</b>		
225	—	10 (254)	6 (152)
400	—	10 (254)	6 (152)
600	—	10 (254)	6 (152)
800	400	10 (254)	6 (152)
1000	—	11 (279)	7 (178)
1200	600	12 (305)	8 (203)
1350	800	12 (305)	8 (203)
1600	1000	13 (330)	9 (229)
2000	1200,1350	15 (381)	11 (279)
—	1600	15 (381)	11 (279)
2500	2000	17 (432)	13 (330)
3000	—	18 (457)	14 (356)
3200	—	19 (483)	15 (381)
4000	2500,3000,3200	21 (533)	17 (432)
5000	4000	26 (660)	22 (559)

### Wall, Ceiling and Floor Flanges

Wall/Floor flanges are available for Sentron Busway. When the busway run passes through a wall, ceiling or floor, a flange should be used. Flanges do not offer support to the busway. Flanges provide a means of covering the hole created in the existing structure. Additional sealant may be required to meet fire codes and all other local requirements. No caulking or gasketing is provided with Sentron flanges.

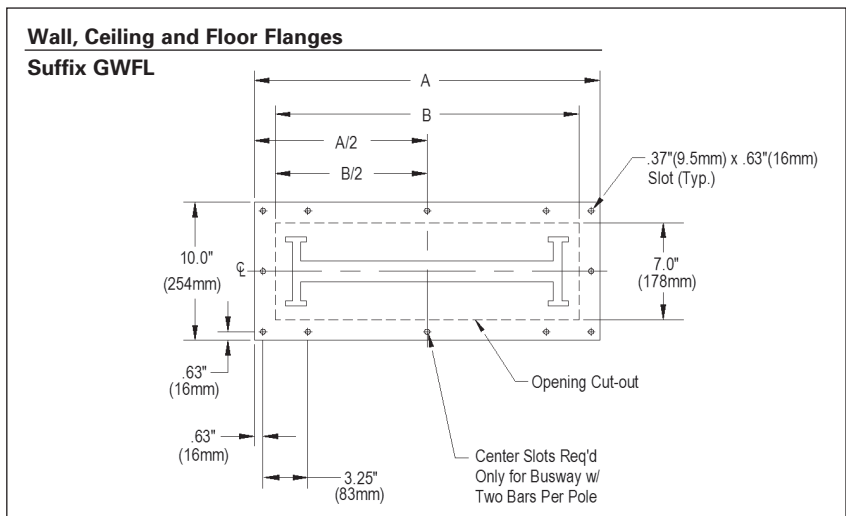

# Sentron Busway Systems

The following table identifies the approximate feeder footage that is included in busway fittings.

Ampere Rating	Elbow Stack	Elbow	Tee	Cross	Tap Box End	Tap Box Center	Flanged End Swbd. Conn.	XFMR Throat	Expansion Section	Reducer Fusible	Reducer Unfused
225–1350 Al 225–1600 Cu	0'	2'	3'	4'	1'	4'	1'	4'	4'	4'	4'
1600–3200 Al 2000–4000 Cu	0'	3'	5'	6'	1'	4'	1'	4'	4'	4'	4'
4000 Al 5000 Cu	0'	4'	6'	8'	1'	4'	1'	4'	4'	4'	4'

Watch the Joint Assembly video



**"M" Rating / Standard Rating Conversion Table**

1000/A Square Inch "M" Rating	Standard Rating Equivalent Sentron
225	600
400	800
600	1200
800	1350
1000	1600
1200	2000
1350	2000
1600	—
2000	2500
2500	4000
3000	4000
3200	4000
4000	5000

**"L" Rating / Standard Rating Conversion Table**

750/A Square Inch "L" Rating	Standard Rating Equivalent Sentron
225	600
400	800
600	1000
800	1200
1000	1350
1200	1600
1350	2000
1600	2000
2000	2500
2500	3000
3000	4000
3200	4000

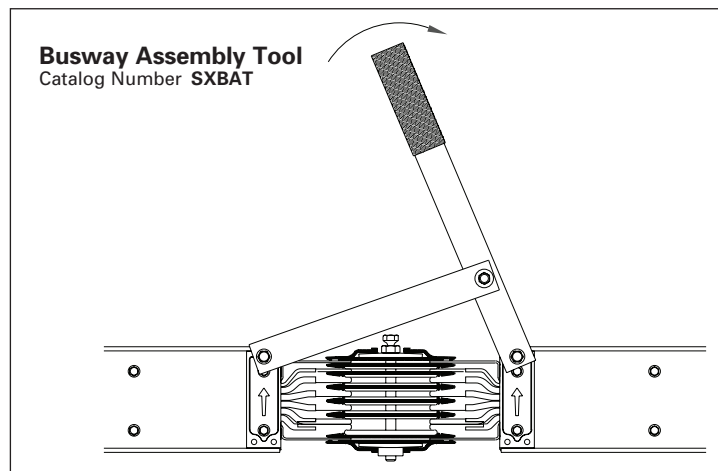
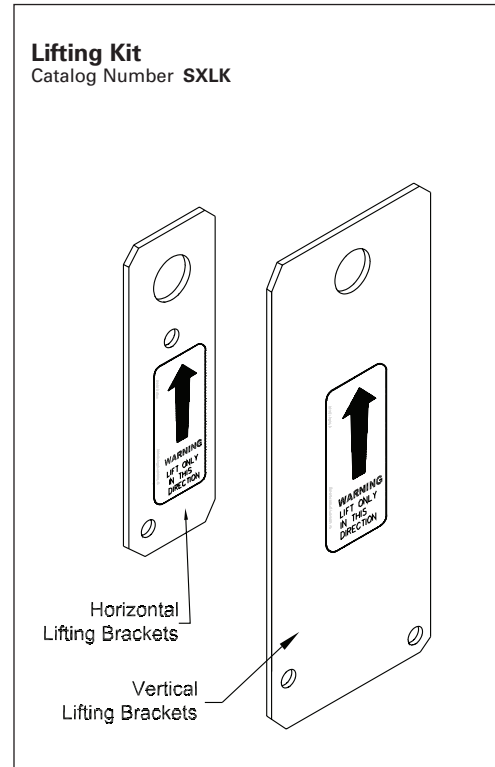
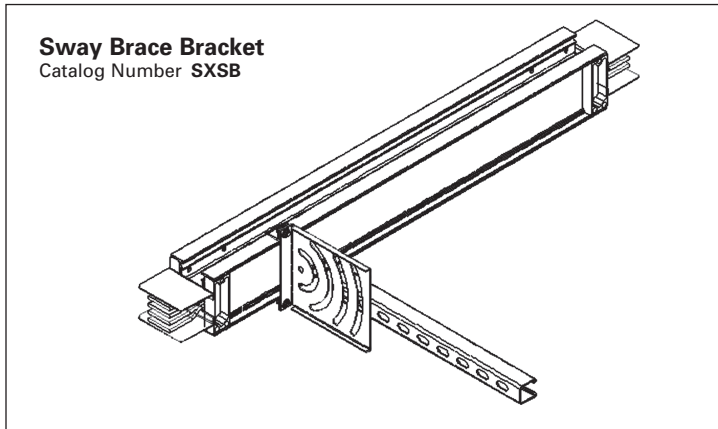

# Sentron Busway Systems

## Flanged Ends

## Selection

Flanged ends provide a direct connection to low-voltage switchgear, switchboards, motor control centers, large power panels, and other electrical distribution equipment.

Flanged ends are shipped with one joint stack assembly. The switchgear manufacture supplies lugs and mounting hardware. See illustration for flanged end drilling patterns.

Flanged End, Dimensions		Dimensions Inches (mm)	
Ampere Rating		"W"	Fig. No.
<b>AL</b>	<b>L-Rated</b>		
225	—	1.75 (44.4)	1
400	—	1.75 (44.4)	1
600	—	1.75 (44.4)	1
800	400	2.38 (60.5)	1
1000	600	3.25 (82.6)	1
1200	800	4.38 (111.3)	1
1350	1000	5.38 (136.7)	1
1600	1200	6.50 (165.1)	1
2000	1350,1600	8.75 (222.3)	1
2500	2000	5.63 (143.0)	2
3000	2500	6.75 (171.5)	2
3200	2000	6.75 (171.5)	2
4000	3000,3200	9.00 (228.6)	2
<b>CU</b>	<b>M-Rated</b>		
225	—	1.75 (44.4)	1
400	—	1.75 (44.4)	1
600	—	1.75 (44.4)	1
800	400	1.75 (44.4)	1
1000	—	2.25 (57.2)	1
1200	600	2.88 (73.2)	1
1350	800	3.50 (88.9)	1
1600	1000	4.50 (114.3)	1
2000	1200,1350	6.00 (152.4)	1
—	1600	6.50 (165.1)	1
2500	2000	8.50 (215.9)	1
3000	—	4.75 (120.7)	2
3200	—	5.50 (139.7)	2
4000	2500,3000,3200	6.50 (165.1)	2
5000	4000	8.50 (215.9)	2

### Flanged End Suffix FRND

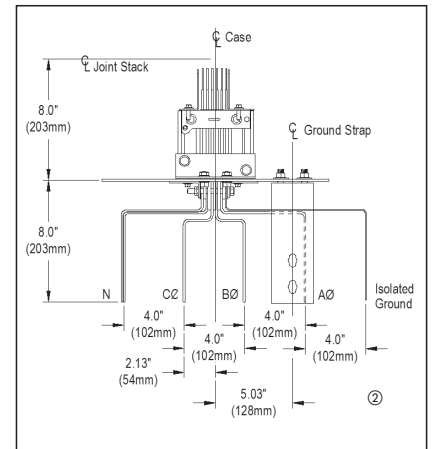
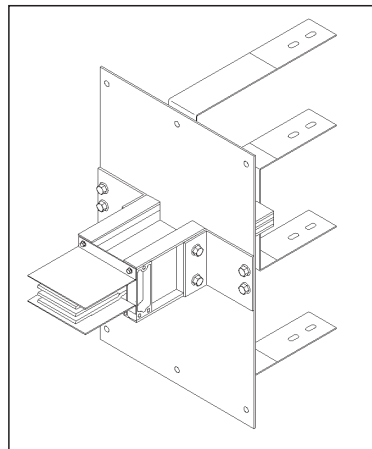
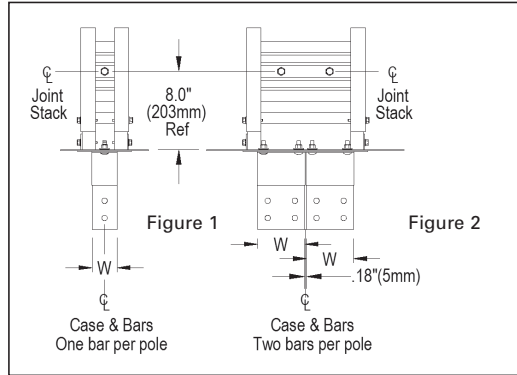

### Flanged End Bus Bar Drilling Pattern (NEMA)Ⓞ

(Same pattern for 2 bus bars per pole, see figure 2 above.)

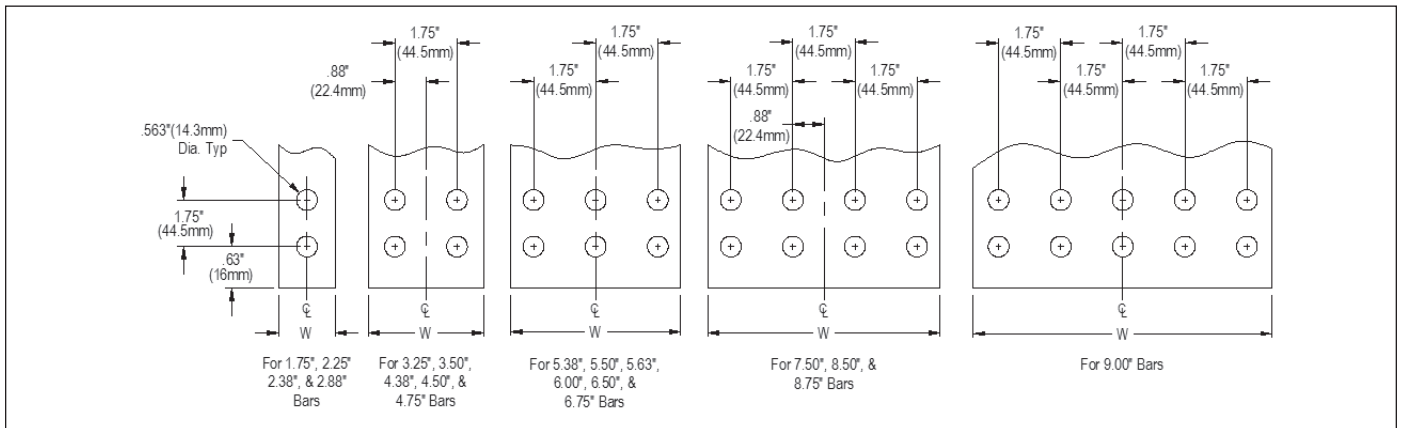

Ⓞ Other drilling patterns are available and must be specified at order entry.  
 Ⓜ See Figures 4, 5 and 6 on page 15-32.



# Sentron Busway Systems

Flanged Ends

Selection

Flanged End, Dimensions (standard/min.)											
Ampere Rating		Dimensions Inches (mm)									
		Ref. Bar Width	Fig. No.	"A"	"B"	"C"	"D"	"E"	"F"	"G"	Fig. No.
<b>AL</b>	<b>L-Rated</b>										
225	—	2.38 (60.5)	1	10.0 (254)	8.00 (203)	4.38 (111)	1.94 (49)	3.88 (99)	—	6.00 (152)	4, 5
400	—	2.38 (60.5)	1	10.0 (254)	8.00 (203)	4.38 (111)	1.94 (49)	3.88 (99)	—	6.00 (152)	4, 5
600	—	2.38 (60.5)	1	10.0 (254)	8.00 (203)	4.38 (111)	1.94 (49)	3.88 (99)	—	6.00 (152)	4, 5
800	400	2.38 (60.5)	1	10.0 (254)	8.00 (203)	4.38 (111)	1.94 (49)	3.88 (99)	—	6.00 (152)	4, 5
1000	600	3.25 (82.6)	1	10.0 (254)	8.00 (203)	4.38 (111)	1.94 (49)	2.06 (52)	—	6.00 (152)	4, 6
1200	800	4.38 (111.3)	2	15.50 (395)	13.50 (343)	7.13 (181)	1.60 (41)	3.19 (81)	—	8.50 (216)	4, 6
1350	1000	5.38 (136.7)	2	15.50 (395)	13.50 (343)	7.13 (181)	2.10 (53)	4.19 (106)	—	8.50 (216)	4, 6
1600	1200	6.50 (165.1)	2	15.50 (395)	13.50 (343)	7.13 (181)	2.66 (67)	5.31 (135)	—	8.50 (216)	4, 6
2000	1350,1600	8.75 (222.3)	2	15.50 (395)	13.50 (343)	7.13 (181)	3.78 (96)	7.56 (192)	—	8.50 (216)	4, 6
2500	2000	5.63 (143.0)	3	20.0 (508)	18.00 (457)	4.50 (114)	0.68 (17)	1.37 (36)	4.44 (113)	13.25 (337)	4, 6
3000	2500	6.75 (171.5)	3	20.0 (508)	18.00 (457)	4.50 (114)	0.68 (17)	1.37 (36)	5.56 (141)	13.25 (337)	4, 6
3200	2000	7.50 (190.5)	4	24.0 (610)	22.0 (569)	5.50 (140)	0.68 (17)	1.37 (36)	6.32 (161)	13.25 (337)	4, 6
4000	3000,3200	9.00 (228.6)	4	24.0 (610)	22.0 (569)	5.50 (140)	0.68 (17)	1.37 (36)	7.81 (198)	14.25 (362)	4, 6
<b>CU</b>	<b>M-Rated</b>										
225	—	1.75 (44.4)	1	10.0 (254)	8.00 (203)	4.38 (111)	1.63 (41)	3.25 (83)	—	6.00 (152)	4, 5
400	—	1.75 (44.4)	1	10.0 (254)	8.00 (203)	4.38 (111)	1.63 (41)	3.25 (83)	—	6.00 (152)	4, 5
600	—	1.75 (44.4)	1	10.0 (254)	8.00 (203)	4.38 (111)	1.63 (41)	3.25 (83)	—	6.00 (152)	4, 5
800	400	1.75 (44.4)	1	10.0 (254)	8.00 (203)	4.38 (111)	1.63 (41)	3.25 (83)	—	6.00 (152)	4, 5
1000	—	2.25 (57.2)	1	10.0 (254)	8.00 (203)	4.38 (111)	1.88 (48)	3.75 (95)	—	6.00 (152)	4, 5
1200	600	2.88 (73.2)	1	10.0 (254)	8.00 (203)	4.38 (111)	0.85 (21)	1.69 (43)	—	6.00 (152)	4, 6
1350	800	3.50 (88.9)	1	10.0 (254)	8.00 (203)	4.38 (111)	1.16 (29)	2.31 (59)	—	6.00 (152)	4, 6
1600	1000	4.50 (114.3)	2	15.50 (395)	13.50 (343)	7.13 (181)	1.66 (42)	3.31 (84)	—	8.50 (216)	4, 6
2000	1200,1350	6.00 (152.4)	2	15.50 (395)	13.50 (343)	7.13 (181)	2.41 (62)	4.81 (122)	—	8.50 (216)	4, 6
—	1600	6.50 (165.1)	2	15.50 (395)	13.50 (343)	7.13 (181)	2.66 (67)	5.31 (135)	—	8.50 (216)	4, 6
2500	2000	8.50 (215.9)	2	15.50 (395)	13.50 (343)	7.13 (181)	3.66 (93)	7.31 (186)	—	8.50 (216)	4, 6
3000	—	4.75 (120.7)	3	20.0 (508)	18.00 (457)	4.50 (114)	0.68 (17)	1.37 (36)	3.56 (90)	13.25 (337)	4, 6
3200	—	5.50 (139.7)	3	20.0 (508)	18.00 (457)	4.50 (114)	0.68 (17)	1.37 (36)	4.32 (110)	13.25 (337)	4, 6
4000	2500,3000,3200	6.50 (165.1)	3	20.0 (508)	18.00 (457)	4.50 (114)	0.68 (17)	1.37 (36)	5.31 (135)	13.25 (337)	4, 6
5000	4000	8.50 (215.9)	4	24.0 (610)	22.00 (569)	5.50 (140)	0.68 (17)	1.37 (36)	7.31 (186)	14.25 (362)	4, 6

15 BUSWAY SYSTEMS

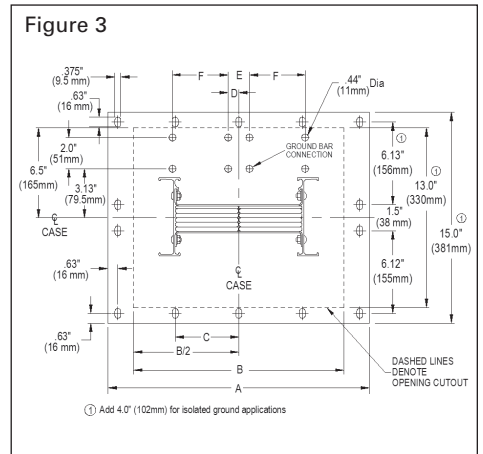
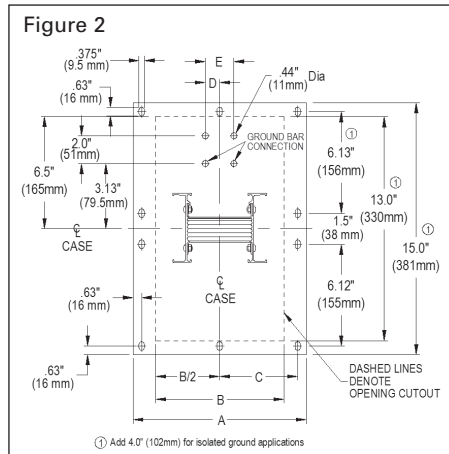
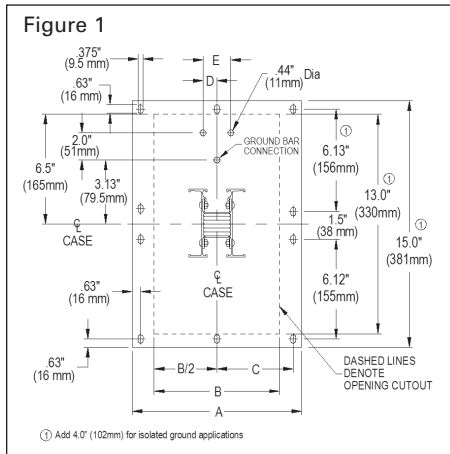

### Integral and Internal Ground Strap Drilling Detail

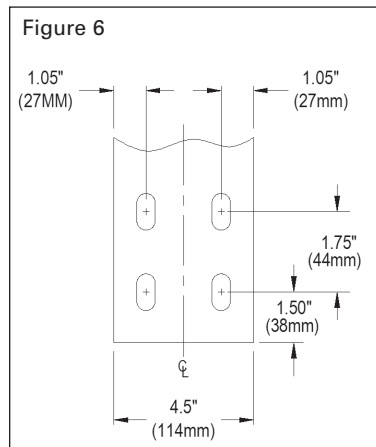
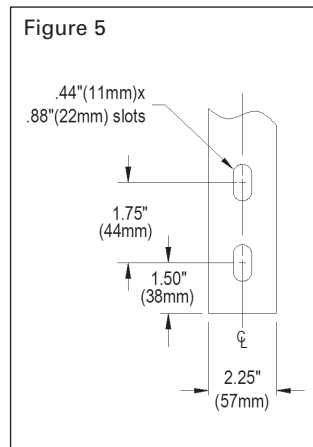
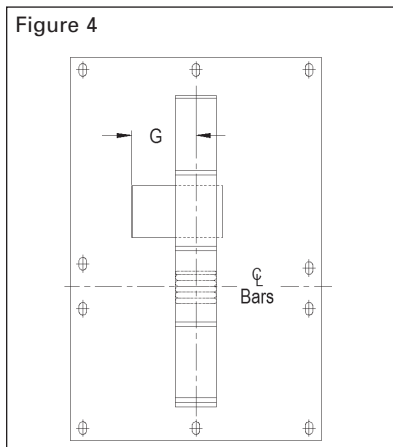

# Sentron Busway Systems

## Combination Flange/Elbows

Selection

### Combination Flange/Elbow

A combination Flange/Elbow may be used in space constrained applications. Flatwise and edgewise combination flange/elbows require a minimum clearance of 5 in. (127mm) from the top of the connecting equipment to the centerline of the busway.

#### Flat Elbow with Flanged End, Dimensions

Ampere Rating	Dimensions inches (mm)							
	Minimum		Maximum		Minimum		Maximum	
	"A"	"B"	"A"	"B"	"A"	"B"	"A"	"B"
800	4.75 (121)	12 (305)	22 (559)	48 (1219)	4.50 (121)	12 (305)	22 (559)	48 (1219)
1000	5.20 (132)	12 (305)	22 (559)	48 (1219)	4.70 (121)	12 (305)	22 (559)	48 (1219)
1200	5.75 (146)	12 (305)	22 (559)	48 (1219)	5.00 (121)	12 (305)	22 (559)	48 (1219)
1350	6.25 (159)	12 (305)	22 (559)	48 (1219)	5.30 (121)	12 (305)	22 (559)	48 (1219)
1600	6.80 (173)	18 (457)	22 (559)	48 (1219)	5.80 (121)	12 (305)	22 (559)	48 (1219)
2000	8.00 (203)	18 (457)	28 (711)	48 (1219)	6.60 (121)	12 (305)	22 (559)	48 (1219)
2500	9.30 (236)	18 (457)	28 (711)	48 (1219)	7.80 (121)	18 (457)	28 (711)	48 (1219)
3000	10.40 (264)	18 (457)	28 (711)	48 (1219)	8.40 (121)	18 (457)	28 (711)	48 (1219)
3200	11.15 (283)	18 (457)	28 (711)	48 (1219)	9.20 (234)	18 (457)	28 (711)	48 (1219)
4000	12.70 (323)	24 (607)	34 (864)	48 (1219)	10.20 (121)	18 (457)	28 (711)	48 (1219)
5000					12.20 (121)	24 (607)	34 (864)	48 (1219)

#### Edge Elbow with Flanged End, Dimensions

Minimum		Maximum	
"A"	"B"	"A"	"B"
5.00 (127)	10 (254)	18 (457)	48 (1219)

#### Edge Elbow with Flanged End

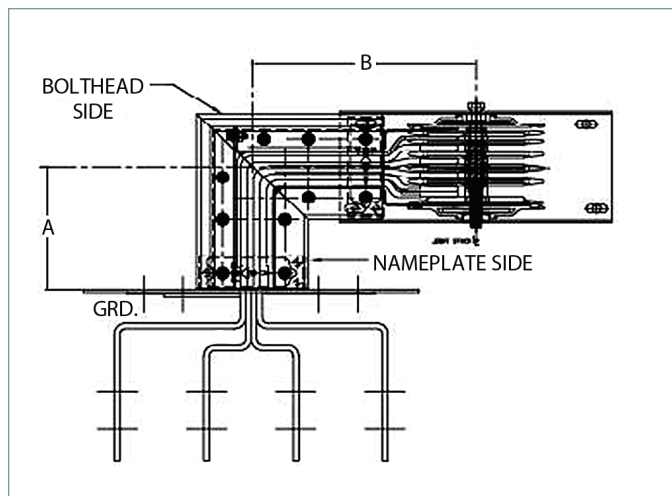

#### Flat Elbow with Flanged End

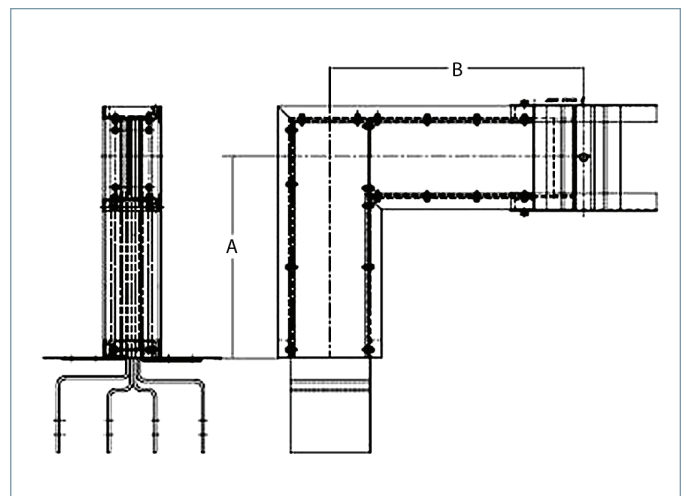

# Sentron Busway Systems

## Cubicle Options

## Selection

In-Line Disconnect Cubicle, Dimensions ②	
Description of Unit	Type of Disconnect
Fusible Switch	800-1200A Vacu-Break
Molded Case Circuit Breaker	JD6, LD6, MD6, ND6 PD6, RD6
Digital Sentron Series MCCB's	SJD6, SLD6, SMD6, SND6 SPD6 1600A Frame
Power Circuit Breaker	200-5000A WL ①
Bolted Pressure Switch	800A 1200-2500A 3000A 4000A
ACCESS-compatible	

① Consult your local Siemens sales office for details on WL breakers.  
② Consult factory for dimensions.

### Fusible Cubicles ①③

3-Pole, 600V/4-Pole, 480/277V

Ampere Ratings:
800
1200

### Bolted Pressure Switches ③

3-Pole 480V, 4-Pole 480V,  
3-Pole 600V or 4-Pole 600V

Ampere Ratings:
800
1200
1600
2000
2500
3000
4000

### Solid State Molded Case Circuit Breaker Cubicles ③

3-Pole, 600V or 4-Pole 480/277V

Breaker Frame	Ampere Rating
SJD6-A, SHJD6-A, SCJD6-A	200-400
SLD6-A, SHLD6-A, SCLD6-A	300-600
SMD6, SHMD6, SCMD6-A	600-800
SND6, SHND6, SCND6-A	800-1200
SPD6, SHPD6	1400-1600

① Fuses not included.  
② For electrically operated, specify control voltage.  
③ IP40 and IP55

### In-Line Disconnect Cubicles

Cubicles provide a means of mounting switches or circuit breakers where power feeds to or pulls from the busway system. When bolted connections are preferred, cubicles may be used in place of plug-in units. Cubicles can also be used at ampere ratings that exceed standard plug-in unit ratings. Modifications to cubicles can be made in order to accommodate key inter-locks, ground fault detector systems and power monitoring systems.

#### In-Line Disconnect Cubicle

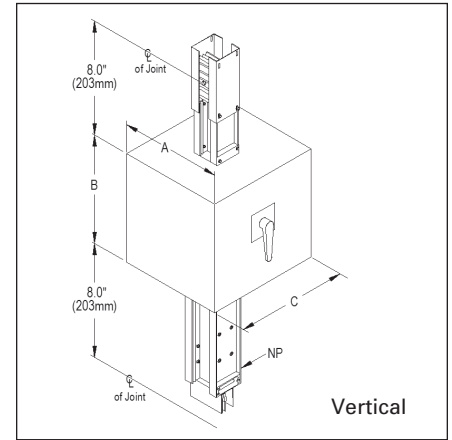
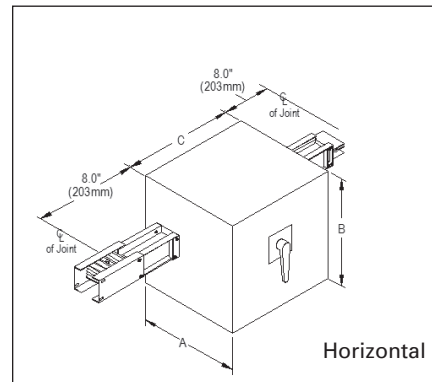

### Molded Case Circuit Breaker Cubicles

3-Pole, 600V or 4-Pole 480/277V

Breaker Type	Ampere Rating
FD6	70-250A
JD6	200-400A
LD6	450-600A
MD6	500-800A
ND6	900-1200A
PD6	1200-1600A
RD6	1600-2000A

### Current-Limiting

3-Phase, 600V AC or  
120/280V AC, 277/480V AC

Breaker Type	Ampere Rating
CFD6	70-250A
CJD6	200-400A
CLD6	450-600A
CMD6	600-800A
CND6	900-1200A
CPD6	1200-1600A

### Power Circuit Breaker ②③

3-Pole or 3-Phase, 4-Wire

Breaker Frame Type	Max. Amp. Rating	Interrupting current frame Ics (kAIR RMS) 50/60 Hz								
		240 Volt			480 Volt			600 Volt		
<b>Type WL</b>										
Frame Size 1 (S, H, L Rating Class)	2000A	65k	85k	100k	65k	85k	100k	65k	85k	100k
Frame Size 2 (S, L, C Rating Class)	3000A	65k	100k	150k	65k	100k	150k	65k	100k	150k
Frame Size 3 (L and C Rating Class)	5000A	—	100k	150k	—	100k	150k	—	85k	100k

### In-Line Disconnect Cubicle, Approximate Dimensions

Description of Unit	Type of Disconnect	Dimensions in Inches		
		A	B	C
Fusible Switch	800-1200A Vacu-Break	36 (914)	36 (914)	32 (813)
Molded Case Circuit Breaker	JD6, LD6, MD6, ND6	36 (914)	28 (711)	28 (711)
	PD6, RD6	36 (914)	36 (914)	32 (813)
Digital Sentron Series MCCB's	SJD6, SLD6, SMD6, SND6	36 (914)	28 (711)	28 (711)
	SPD6, 1600A Frame	36 (914)	36 (914)	32 (813)
Power Circuit Breaker	WL Frame Size 1	48 (1219)	36 (914)	32 (813)
	WL Frame Size 2	48 (1219)	36 (914)	32 (813)
	WL Frame Size 3	48 (1219)	36 (914)	32 (813)
Bolted Pressure Switch	800A	33 (838)	36 (914)	32 (813)
	1200-2500A	37 (940)	40 (1016)	32 (813)
	3000A	37 (940)	40 (1016)	48 (1219)
	4000A	41 (1041)	40 (1016)	48 (1219)

# Sentron Busway Systems

## Panelboards and Meter Center Modules

Selection

Meter center modules provide a quick and convenient method of connecting to metering devices for both commercial and industrial applications.

Meter center modules connect at the side of a busway run to special joint stacks; these special joints can be added to existing busway to accommodate meter center module connections. When using multiple metering stacks, main disconnects are available if the system reaches the 6 circuit rule (see metering bulletin for further information).

### Dimensional Data Required

#### Dimensions Inches (mm)

- "A" Distance between floor and bottom of meter center as required by the customer.
- "B" Dimension from bottom of meter center to centerline of meter center joint connection stack:  
100-125A Panel, B = 16.5 (419)  
200A Panel, B = 22.0 (559)
- "C" Equals "A" plus "B", Minimum 16.0 (406)
- "D" Individual meter center height. Consult Modular Metering application information.

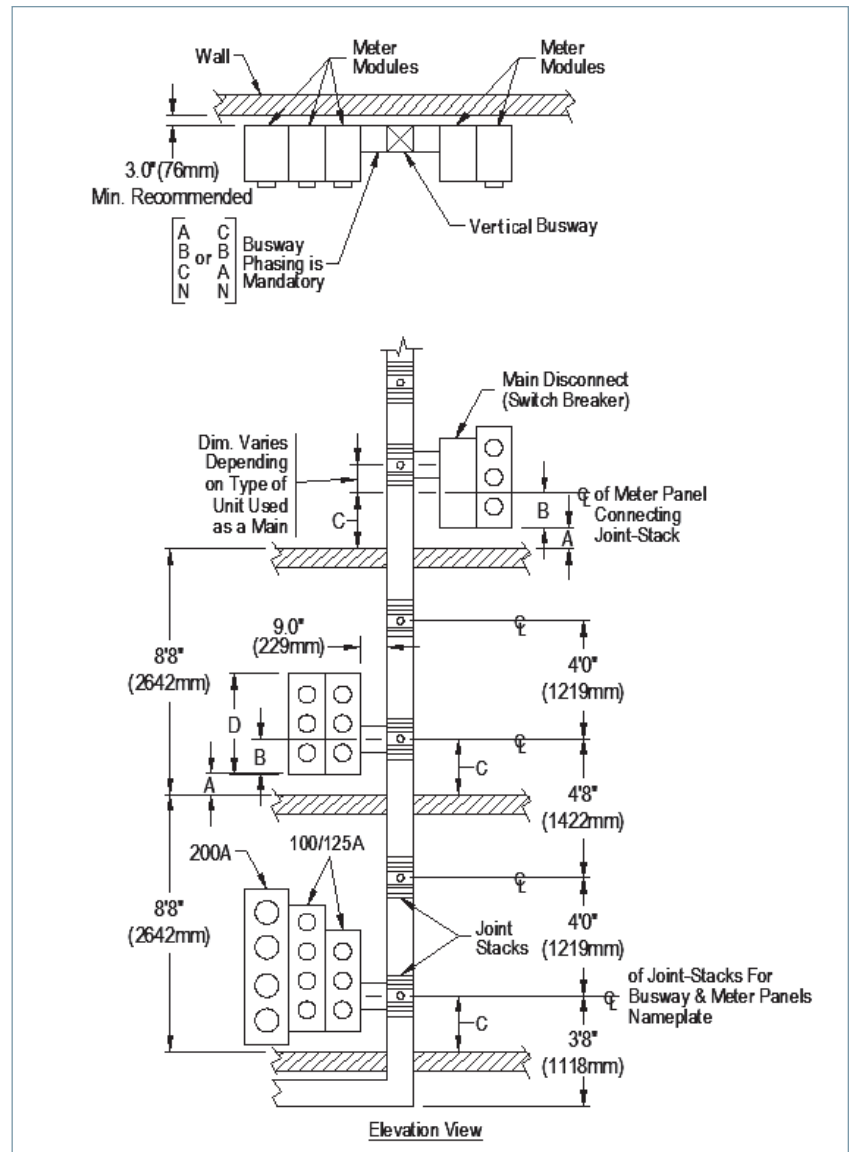

# Sentron Busway Systems

Selection

## Meter Center Cubicles

Meter center cubicles provide a quick and convenient method of connecting to metering devices for both commercial and industrial applications and have the main disconnect circuit breaker factory installed.

Having the main disconnect built into the device reduces the required space on the right and left side of the busway. Meter center modules connect at the side of the cubicle frame box using an QC4 stack. Meter center cubicles are available for 600 – 1200 Amp (L, M and N Frames). They are available with flexible meter center connections, left side, right side or both. (When ordering a meter center cubicle a QC4 stack must be ordered separately.)

Molded Case Circuit Breaker Cubicles with Meter Tap Stack Provisions Dimensions, Inches (mm)											
Ampere Rating	Busway Width W	L Frame Breaker (250-600A)			M Frame Breaker (250-800A)			N Frame Breaker (800-1200A)			
		A	B	C	A	B	C	A	B	C	
<b>AL L-Rated</b>											
225 —	3.9 (99)	32 (813)	24 (620)	16 (406)	37 (940)	26 (660)	16 (406)	37 (940)	26 (660)	16 (406)	
400 —	3.9 (99)	32 (813)	24 (620)	16 (406)	37 (940)	26 (660)	16 (406)	37 (940)	26 (660)	16 (406)	
600 —	3.9 (99)	32 (813)	24 (620)	16 (406)	37 (940)	26 (660)	16 (406)	37 (940)	26 (660)	16 (406)	
800 400	4.6 (117)	32 (813)	24 (610)	16 (406)	37 (940)	26 (660)	16 (406)	37 (940)	26 (660)	16 (406)	
1000 600	5.4 (137)	32 (813)	24 (610)	16 (406)	37 (940)	26 (660)	16 (406)	37 (940)	26 (660)	16 (406)	
1200 800	6.6 (168)	32 (813)	24 (610)	16 (406)	37 (940)	26 (660)	16 (406)	37 (940)	26 (660)	16 (406)	
1350 1000	7.6 (193)	32 (813)	24 (610)	16 (406)	37 (940)	26 (660)	16 (406)	37 (940)	26 (660)	16 (406)	
1600 1200	8.7 (221)	32 (813)	24 (610)	20 (490)	37 (940)	26 (660)	20 (490)	37 (940)	26 (660)	20 (490)	
2000 1350,1600	10.9 (277)	32 (813)	24 (610)	20 (490)	37 (940)	26 (660)	20 (490)	37 (940)	26 (660)	20 (490)	
2500 2000	13.7 (348)	32 (813)	24 (610)	23.5 (597)	37 (940)	26 (660)	23.5 (597)	37 (940)	26 (660)	23.5 (597)	
3000 2500	15.8 (401)	32 (813)	24 (610)	23.5 (597)	37 (940)	26 (660)	23.5 (597)	37 (940)	26 (660)	23.5 (597)	
3200 2000	17.3 (439)	32 (813)	24 (610)	23.5 (597)	37 (940)	26 (660)	28 (711)	37 (940)	26 (660)	28 (711)	
4000 3000,3200	20.3 (516)	32 (813)	24 (610)	28 (711)	37 (940)	26 (660)	28 (711)	37 (940)	26 (660)	28 (711)	
4000 3000,3200	20.3 (516)	32 (813)	24 (610)	28 (711)	37 (940)	26 (660)	28 (711)	37 (940)	26 (660)	28 (711)	
<b>CU M-Rated</b>											
225 —	3.9 (99)	32 (813)	24 (620)	16 (406)	37 (940)	26 (660)	16 (406)	37 (940)	26 (660)	16 (406)	
400 —	3.9 (99)	32 (813)	24 (620)	16 (406)	37 (940)	26 (660)	16 (406)	37 (940)	26 (660)	16 (406)	
600 —	3.9 (99)	32 (813)	24 (620)	16 (406)	37 (940)	26 (660)	16 (406)	37 (940)	26 (660)	16 (406)	
800 400	3.9 (99)	32 (813)	24 (620)	16 (406)	37 (940)	26 (660)	16 (406)	37 (940)	26 (660)	16 (406)	
1000 —	4.4 (112)	32 (813)	24 (610)	16 (406)	37 (940)	26 (660)	16 (406)	37 (940)	26 (660)	16 (406)	
1200 600	5.1 (130)	32 (813)	24 (610)	16 (406)	37 (940)	26 (660)	16 (406)	37 (940)	26 (660)	16 (406)	
1350 800	5.7 (145)	32 (813)	24 (610)	16 (406)	37 (940)	26 (660)	16 (406)	37 (940)	26 (660)	16 (406)	
1600 1000	6.7 (170)	32 (813)	24 (610)	16 (406)	37 (940)	26 (660)	16 (406)	37 (940)	26 (660)	16 (406)	
2000 1200,1350	8.2 (208)	32 (813)	24 (610)	20 (490)	37 (940)	26 (660)	20 (490)	37 (940)	26 (660)	20 (490)	
— 1600	8.7 (221)	32 (813)	24 (610)	20 (490)	37 (940)	26 (660)	20 (490)	37 (940)	26 (660)	20 (490)	
2500 2000	10.7 (272)	32 (813)	24 (610)	20 (490)	37 (940)	26 (660)	20 (490)	37 (940)	26 (660)	20 (490)	
3000 —	11.8 (300)	32 (813)	24 (610)	20 (490)	37 (940)	26 (660)	20 (490)	37 (940)	26 (660)	20 (490)	
3200 —	13.3 (335)	32 (813)	24 (610)	20 (490)	37 (940)	26 (660)	23.5 (597)	37 (940)	26 (660)	23.5 (597)	
4000 2500,3000,3200	15.3 (389)	32 (813)	24 (610)	23.5 (597)	37 (940)	26 (660)	23.5 (597)	37 (940)	26 (660)	23.5 (597)	
5000 4000	19.3 (491)	32 (813)	24 (610)	28 (711)	37 (940)	26 (660)	28 (711)	37 (940)	26 (660)	28 (711)	

15 BUSWAY SYSTEMS

### Meter Center Module

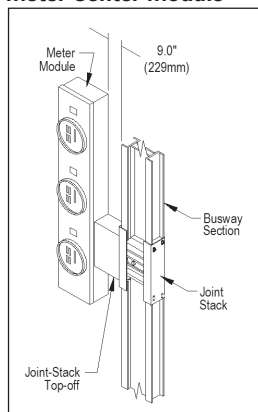

### Side Mount Panelboard

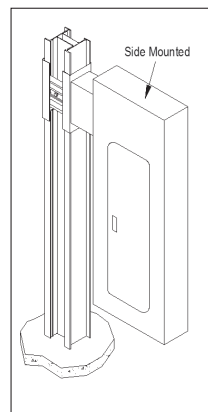

For this panelboard configuration, please contact Spartanburg plant for mounting information. Configuration only available for P2 and P3 panels in 240V or below applications.

### Main Disconnect Meter Module

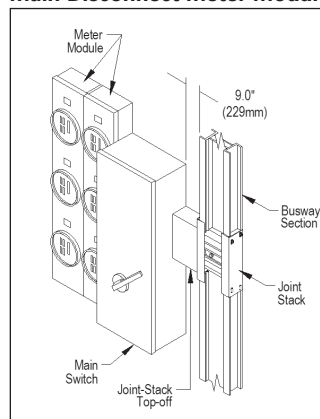

### Meter Center Cubicle

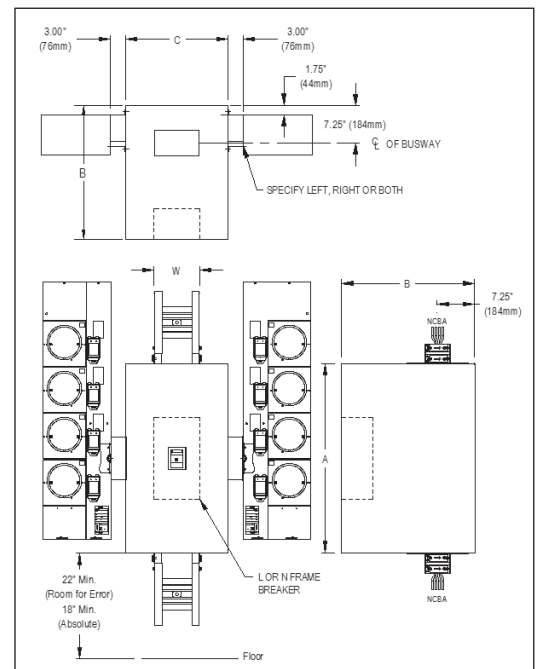

# Sentron Busway Systems

## Installation and Application Information

## Selection

### Installation

In preparation for installation of your busway systems, it is important to familiarize yourself with the following installation publications:

- General Instructions For Handling, Installation, Operation and Maintenance of Busway Rated 600 Volts or Less (NEMA Standards Publication BU1.1)
- Storage, Installation and Maintenance Instructions for Sentron Busway

These publications should be read through thoroughly and used as reference during installation to ensure proper installation procedures. All equipment should be inspected upon delivery. If the busway is not installed immediately, it should be stored in a clean, dry location. Factory supplied record drawings as well as installation tools should be accessible in preparation for installation.

Video content illustrating bus plug installation, joint assembly, and support installation is also available and meant to compliment the two aforementioned documents.

### UL 1479 Fire Rated Installations

Sentron Busway has been tested in accordance with UL 1479 and offers a certified two hour fire rating for gypsum wallboard construction and a three hour fire rating for concrete slab or block penetrations. These ratings were achieved using standard busway installed with SpecSeal sealant from Specified Technologies Inc. The SpecSeal fire stop system provides superior performance at the industry's lowest installed cost.

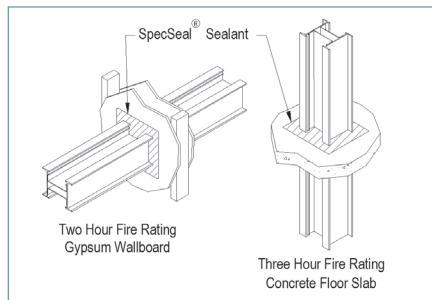

Sentron Busway Clean Order Form

**SIEMENS**

**Order information:**

Sales Engineer: \_\_\_\_\_

Order Status: Released  Hold for Release



Run Designation: \_\_\_\_\_

Busway Catalog #: \_\_\_\_\_

Plating Type: Tin  or Silver

Special Paint, provide paint chip \_\_\_\_\_

Busway mounting position in reference to the floor

**Busway Check List:**

- Field sketches or factory approval drawings attached?
- Dimensions from walls, column lines, etc.
- Wall, floor and roof thickness and pitch
- Floor Elevations
  - Floor to floor \_\_\_\_\_
  - Floor to ceiling \_\_\_\_\_
- Wall location Dimensions (indicate on drawing)
- Equipment pads / curbs Height \_\_\_\_\_
- Existing Busway to be extended cat # \_\_\_\_\_
  - Phasing \_\_\_\_\_
  - Nameplate Information \_\_\_\_\_
  - Match to competitor. Contact the plant \_\_\_\_\_
- Special SWBD connection, provide details \_\_\_\_\_
- Phase Transpositions: (indicate phasing on drawing)

Special Comments

**Example page of busway clean order form. Please contact your local Siemens sales representative.**

### Measuring

Critical to the success of any busway installation is the layout and the accurate measuring of the busway. First and foremost:

Select a route for your busway that will require the fewest fittings and the maximum number of 10' (3.05m) sections. It is important that the busway system be designed to meet the requirements of the National Electric Code for Busway. There are a number of techniques that may be used to ensure an accurate measurement before purchasing and installing the busway. The following tools will be required during layout and measuring:

- Laser measurement device
- Measuring stick
- Chalkline
- Plumb bob
- Marker

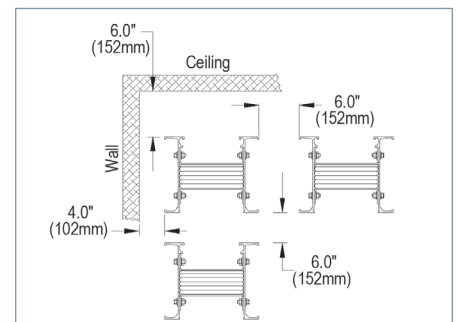

### Minimal Clearances

Minimum clearances for installing feeder busway are shown. Additional clearance may be required for plug-in devices larger than 100A fusible and 250A circuit breaker.

Watch Busway joint assembly video



Watch Busway support video



Watch SLVB Bus Plug installation video



**Support and installation videos.**



# Sentron Busway Systems

## General Information

## Selection

### Recommended Measurement Steps

- Using systems requirements for amperage, voltage, and conductors, determine the physical size of the busway. This is important when setting minimum clearances from walls, columns, ceilings and other obstructions. See page 30 for minimal clearances.
- Prior to any layout, review the complete area to determine the best location for the run. Special attention needs to be given to existing equipment such as plumbing, HVAC, steel columns, beams and permanent structures.
- Measure all dimensions from fixed points such as columns, walls, floors and ceilings.
- Make a preliminary sketch showing proposed busway routing, elevations and obstructions. Be sure to show all floor and wall locations including thickness.
- Where plug-in devices are being used, be sure to allow for proper operation clearances. See dimensional requirements shown in the bus plug section of this publication.

Reference the following documents online at [www.usa.siemens.com/busway](http://www.usa.siemens.com/busway).

- Sentron Quick Reference
- Busway Order Entry Checklist
- Sentron Busway Installation and Instruction Guide

### Maintenance

In order to maintain system performance, it is necessary to perform regular maintenance on your busway system. Siemens Storage, Installation and Maintenance Instructions, and NEMA Publication BU1.1 should be used as a guide to proper maintenance procedures. Routine maintenance of your busway system will increase its life and performance.

### Custom Product

With a 60 year history in designing and manufacturing Busway Systems, Siemens can develop custom solutions to meet specific job requirements. Siemens specializes in custom engineered busway sections, connections, and bus plugs. Consult your local Siemens sales office for details on custom pricing and ordering.

### Connecting to Existing Equipment

Do you have existing power distribution equipment (non-Sentron) that you would like to run Sentron Busway to or from? Siemens can engineer special connection pieces that allow you to connect Sentron Busway quickly and efficiently.

### Transformer Connections

Siemens can connect Sentron Busway to almost any transformer. All you need to do is provide complete drawings of transformer secondary connections with detailed drilling pattern and phasing information to your local Siemens sales engineer and they can order you a custom designed connection piece.

### Paint

Sentron Busway products have a protective finish of ANSI 61 gray (standard) polyester urethane powder paint. The paint is electrostatically applied to all housing surfaces. Colors other than ANSI 61 gray may be special ordered.

Low Current Density Busway Sentron Busway may be ordered as 1000 A/in<sup>2</sup> Copper or 750 A/in<sup>2</sup> Aluminum.

Conversion is as follows:

Required M or L Rating	
AL	L-Rated
225	—
400	—
600	—
800	400
1000	600
1200	800
1350	1000
1600	1200
2000	1350,1600
2500	2000
3000	2500
3200	2000
4000	3000,3200

Required M or L Rating	
AL	L-Rated
225	—
400	—
600	—
800	400
1000	—
1200	600
1350	800
1600	1000
2000	1200, 1350
—	1600
2500	2000
3000	—
3200	—
4000	2500, 3000
5000	4000

"L" Rating = 750 A/in<sup>2</sup> Aluminum  
 "M" Rating = 1000 A/in<sup>2</sup> Copper  
 1600 "M" rated is dedicated offering.

# Sentron Busway Systems

## General Information

## Selection

### Applications – 200% Neutral Option

Power system harmonics are created by numerous types of non-linear loads which are often very high in harmonic content. The harmonics generated create problems in electrical systems and equipment. The presence of nonlinear loads can result in overheated neutrals and lead to deterioration of equipment performance and a reduced equipment life cycle. In order to prevent such problems from occurring, the Computer and Business Equipment Manufacturers Association (CBEMA) recommends that the neutral be oversized to at least 173% of the ampacity of the phase conductors to prevent problems. Sentron Busway offers two fully rated bus bars, therefore providing twice the current carrying surface as the phase bars. Each neutral bar is plated with the same tin plating and insulated with the same electrostatically applied epoxy insulation as the phase bars. This 200% neutral capacity helps prevent overheating caused by non-linear loads.

### Isolated Ground

Sentron Busway is available with an optional isolated ground. This isolated ground provides a clean ground path for high frequency signals coming through the ground. This option is very useful in applications where there are computers or diagnostic equipment. The isolated ground option is often used in hospitals and higher technology industry applications.

### Services – Power II Fit Final Connection Program

A “Final Connection” section is a length of busway inserted into a run of busway after the major portion of the busway run has been installed. This allows the release of the majority of the busway run long before the final dimensions are known.

Final Connection pieces must be identified at the time of the original order release with approximate date of Final Connection order. The Final Connection order form should be emailed to Busway Customer Service. For program details visit our website: [www.usa.siemens.com/busway](http://www.usa.siemens.com/busway) or contact your local Siemens sales office.

### Measuring and Layout

For large jobs, Siemens Busway Systems offer assistance with measuring and layout of the busway. This service is negotiated on a job by job basis.

### Emergency Service

Siemens provides a 24-hour emergency service call center where you can call at any time for emergency service. 1.800.241.4453 will put you in touch with a trained professional who will help assess the situation and put you in touch with a product expert.

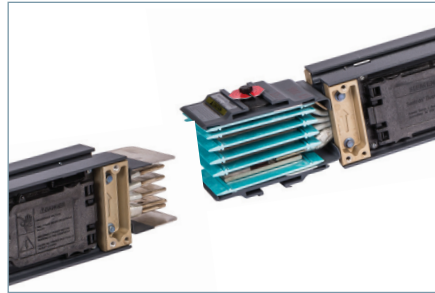

# Sentron Busway Systems

Siemens Sentron Busway Quick Reference

General

## Siemens Sentron Busway Quick Reference

### Critical Dimensions:

Busway that passes through a wall, ceiling or floor:

- Centerline of a joint to the wall, ceiling or floor = 7 in. min.
- Centerline of a joint (*above a floor support*) to a floor = 16 in. min.
- Joints cannot be positioned inside a wall, ceiling or floor (*joints must be accessible for maintenance*).

Feeder Busway clearances:

- From the top of the busway to a ceiling/floor/wall or other busway = 6 in. min.
- From the side of the busway to a ceiling/floor/wall or other busway = 4 in. min.

Plug-in Busway clearances:

- Plug-In busway clearances depend on the configuration of bus plugs (*see bus plug clearance charts in the Sentron Selection and Application Guide*)
- Otherwise, clearances for feeder busway apply.
- Note orientation of the operating handle and provide clearance for access & operation.

Feeder Busway length:

- Minimum length = 14.38 in.
- Maximum length = 10 ft.

Plug-In & Riser length:

- Available only in 4, 6, 8 and 10 ft. lengths

Flat Elbow section:

- Maximum leg length = 4 ft.
- Minimum leg length: Varies according to amperage and bus bar material

Edge Elbow section:

- Maximum length = 4 ft.
- Minimum leg length = 10 in.

Combination and Offset Elbows:

- Maximum leg lengths = 4 ft.
- Minimum leg lengths: varies according to amperage and bus bar material

Elbow - Stub Combinations:

- Maximum leg length = 4 ft.
- Minimum leg length = 2.50 in. + (case size x .5)

### Critical Details:

- Busway DRAWINGS must include all relevant dimensions.
- CENTERLINE dimensions are expected (*please note any dimensions that are not center line dimensions*).
- WALLS and FLOORS must be located (*wall & floor thickness must be included*).
- Locate the **FRONT of all switchboards** and provide the phasing of any existing boards (*advise if any PADs are located under boards and height of pads*).
- When using ONE-SIDED plug-in busway please note the desired direction of the load side of bus plugs (*G,A,B,C,N from left to right will position the load side to the bottom and "UP is On" handle operation*)
- TRANSFORMER THROAT connections require complete details.
- Horizontal plug-in busway must be oriented with the A phase on top (*bolt head on top*).
- In-Line Disconnect CUBICLES are engineered to order. The **FRONT** of the cubicle and **Breaker** information must be specified.
- Panels - panel type and size / if a certain panel or breaker height is required (those dimensions)
- Curb height

### Intermediate Hangers

- Add qty (1) Intermediate Hanger for floor to ceiling height greater than 16ft. Consult factory if greater than 32 ft.

### Expansion Sections:

- Qty (1) Expansion Section should be used for every 200 ft of continuous Busway run length, length, at every transition to a vertical run over 40' in continuous length, and at each building expansion joint.

### Outdoor Busway:

- Route busway to minimize outdoor busway run length.
- Call factory before quoting outdoor busway runs over 50 ft.
- Avoid installing busway near exhaust pipes that may generate steam or caustic vapors.

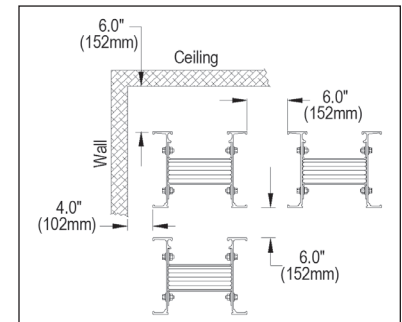

Feeder Busway minimal clearances

# Sentron Busway Systems

## What is the Power II Fit Program?

Siemens PIIF Program compensates for dimensional deviations that may result in busway layouts. With the PIIF Program, specific dimensions on straight sections and/or elbows may be left out of factory released drawings. After the busway run has been installed (minus PIIF pieces), final measurements are taken and sent to your Siemens representative.

### Why use the Power II Fit Program?

The PIIF Program can save you both time and money by eliminating uncertainty in busway measurements. When you take advantage of the PIIF Program, your busway runs fit exactly the first time, eliminating incorrect pieces and costly reordering time.

### When should the Power II Fit Program be used?

The PIIF Program will benefit you when you are uncertain of exact dimensions on long busway runs and when difficult contour situations require special attention. Common applications of the PIIF Program include tie bus or other configurations in which the busway origin and termination are rigidly defined.

### Ordering Details

- Identify Siemens Busway PIIF Pieces at time of original order. Busway Customer Service approves PIIF Pieces.
- Send PIIF Order Form to Busway Customer Service when exact measurements are known.
- Busway Customer Service acknowledges PIIF Order and PIIF pieces ship within lead time per table.

### Program Details

- Product Line: SENTRON.
- Pricing: Included with original order entry.

Table below only applies to Sentron Busway. Consult factory for Legacy Products.

Piece Type	1-3 Pieces <sup>①</sup>	1-5 Total Pieces <sup>①</sup>	6-10 Total Pieces <sup>①</sup>	11 or more Total Pieces <sup>①</sup>
Straight Sections	5 days <sup>③</sup>	5-10 Working Days	10-15 Working Days	Consult factory for lead times
Standard 90 Elbows <sup>②</sup>	N/A	5-15 Working Days	10-20 Working Days	Consult factory for lead times
Non Standard Elbows / Other Fittings <sup>②</sup>	N/A	Consult factory for lead times	Consult factory for lead times	Consult factory for lead times

<sup>①</sup> Lead times are in business days from receipt of complete PIIF Order Form. The number of pieces is calculated based on how many pieces are released in a given week on any project. All orders ship via standard carrier originating from Spartanburg, SC. Ex: 4 straight sections and 2 elbows would be considered 6 total pieces and they would be ready to ship in 10-20 days. All field fit pieces must be shown on layout drawings issued by factory. If pieces are not shown on factory layout drawings as field fits they are not eligible for the field fit program.

<sup>②</sup> Standard 90 elbows are defined in the selection and application guide as 90 degree elbows. Offsets & Combinations will be considered Non Standard Elbows or Other Fittings.

<sup>③</sup> Pending material availability. All sections must be shorter than 5ft from center line to center line if air freight is required. Lengths of pieces should be determined during the approval drawing stage.

## Field Dimension Measurement Guide

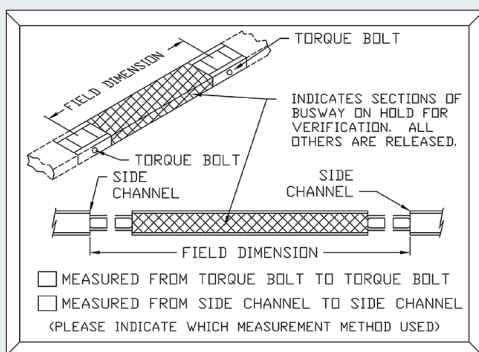

### Straight Sections

Measure the distance "A" between the housings of the connecting sections. Forward this to the factory via the Power II Fit Order Form and we will calculate the length of busway required.

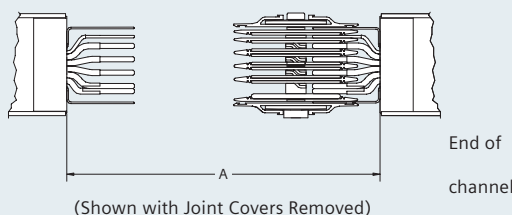

### 90 Degree Elbow Sections:

Measure the distance "X" and "Y" between the housings of the connecting sections. Forward this to the factory via the Power II Fit Order Form and we will calculate the lengths of elbow required.

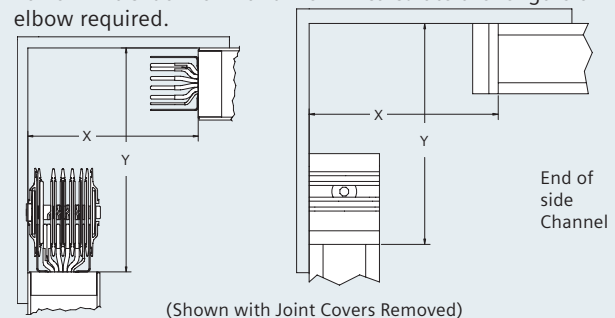

### Elbow Stacks:

Measure the distance "A" between the housings of the connecting sections. Forward this to the factory via the Power II Fit Order Form and we will calculate the lengths of elbow required.

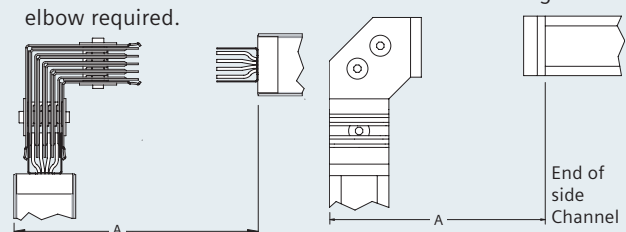

# Sentron Busway Systems

Programs and Services

Selection

## What is the Power II Measure service?

Siemens Power II Measure (PIIM) service provides professional busway routing and measurement by a factory representative. The Siemens representative will meet with the designated site contact to review project details and discuss routing options. Using a laser measuring device, all pertinent site measurements will be recorded and then transferred to a CAD approval drawing(s). The PIIM service guarantees correct alignment and routing of the busway. If there are any errors in the busway routing that resulted from Siemens, replacement busway items will be provided at no charge.

### Why use the Power II Measure service?

The PIIM service can save you both time and money by:

- Ensuring the most cost effective busway routing
- Ensuring accurate measurements
- Reducing order engineering lead-time

### When should the Power II Measure service be used?

The PIIM service can be beneficial for all projects (new or existing, large or small). The PIIM service is especially beneficial for large and/or complex projects.

### Program details

- Product Line: Sentron, XJL, XLU, BD
- Pricing: Fixed daily rate includes travel expenses, site review, measurement service and approval drawings
- Deliverable: An electronic CAD approval package will be submitted within 3 weeks of the site visit. The drawing package will include isometric busway routing with gear orientation, and any special application notes/details.

### Ordering details

- The PIIM service should be ordered at the same time as the busway
- The PIIM service may be ordered for project cost estimation
- Allow 2 weeks notice to schedule the PIIM service

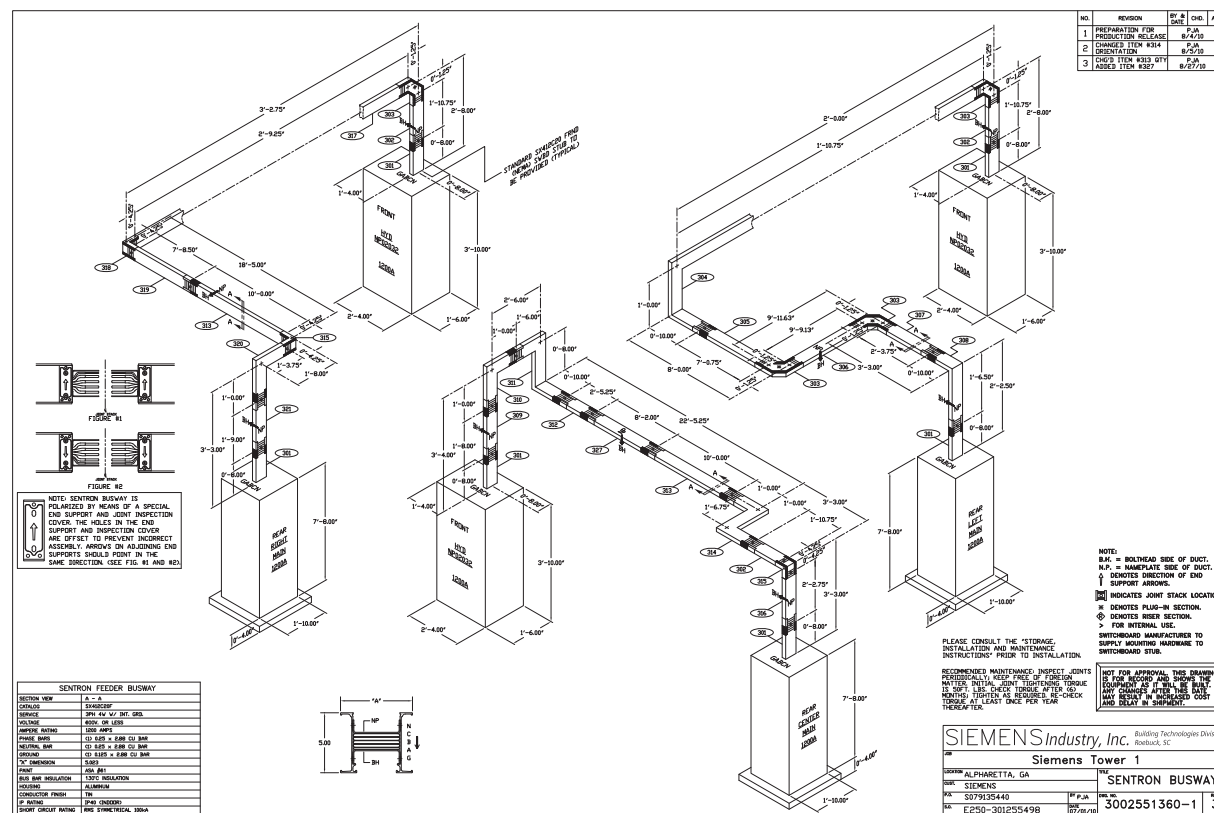

# Sentron Bus Plugs

## Table of Contents



**Non-Metered Sentron 3/6 Bus Plug**



**Sentron SLVB Bus Plug**

### Sentron Busway Systems

Sentron Bus Plug Overview	15-43
Bus Plug Catalog Numbering System	15-44
Circuit Breaker Bus Plugs Dimensions and Weights	15-45
Bus Plugs with Standard Circuit Breakers	15-46
Bus Plugs with Current Limiting Circuit Breakers	15-47
Circuit Breaker Bus Plugs Dimensions and Weights	15-48
Wall Clearance and Circuit Breaker Bus Plug Dimensions	15-49
Fusible Bus Plugs Catalog Numbering System	15-50
Fusible Bus Plugs Ratings	15-51
Fusible Plugs Selection and Ordering	15-52
Fusible Bus Plugs Dimensions and Weights	15-53 – 15-54
Wall Clearance and Fusible Bus Plug Dimensions	15-55
SPD Bus Plugs	15-56
SPD Bus Plugs Catalog Numbering System	15-57
SPD Bus Plugs Dimensions and Weights	15-58
3/6 Bus Plugs	15-59
3/6 Bus Plugs Catalog Numbering System	15-60
3/6 Bus Plugs Product Configuration	15-61
3/6 Bus Plugs Dimensions and Weights	15-62 – 15-63



# Sentron Bus Plugs

## Sentron Bus Plug Overview

## Overview

SENTRON Bus Plugs are engineered with the installer and end user in mind. The installer will benefit from the numerous features, such as factory installed circuit breakers, compact footprint, generous wirebend space, and dual interlocks. The end user will appreciate the visible position indicator, as well as the spring loaded pad lockable latch which prevents access to unauthorized personnel.

SENTRON Bus Plugs are designed with an interlock device to prevent the door from being opened when the disconnect is on. This also prevents the disconnect from being turned on while the door is open. The interlock ensures that the protective device is "OFF" prior to installation or removal of the bus plug. Once the bus plug is properly installed, a spring - loaded, padlock latch provides additional security by preventing unauthorized access to the unit.

Alignment and interlock stabs are features of the Sentron Bus Plugs engineered to prevent improper installation of the unit. Guide stabs prevent installing the bus plug 180 degrees out of rotation. In addition, the stabs provide vertical support for vertical applications. The bus plug ground stabs are designed to ensure positive contact with both the integral and optional internal busway grounds before the bus plug fingers contact the phase and neutral bars. Sentron Bus Plugs also feature bolt-on mounting to the busway housing for secure attachment.

Sentron Bus Plugs can be configured for horizontal or vertical applications. The following Bus Plugs can be mounted (side by side) five (5) per busway side channel (Total 10 per 10' Section).

- 30-600 SLVBH Fusible (Horizontal)<sup>①</sup>
- 30-200 SLVBR Fusible (Riser)<sup>①</sup>
- 30-400 Circuit Breaker<sup>①</sup>
- 10-100A 3/6 Bus Plug (Horizontal)<sup>②</sup>

Sentron SLVB Fusible Bus Plugs feature a direct drive mechanism. The operating handle mounts directly to the switch mechanism for fewer moving parts.

Enclosure Ratings:

- IP40
- IP55

Conductors:

- 3-phase, 3-wire
- 3-phase, 4-wire
- 3-phase, 4-wire 200% neutral (400A and below)

Grounding:

- Integral (Housing)
- Internal
- Isolated

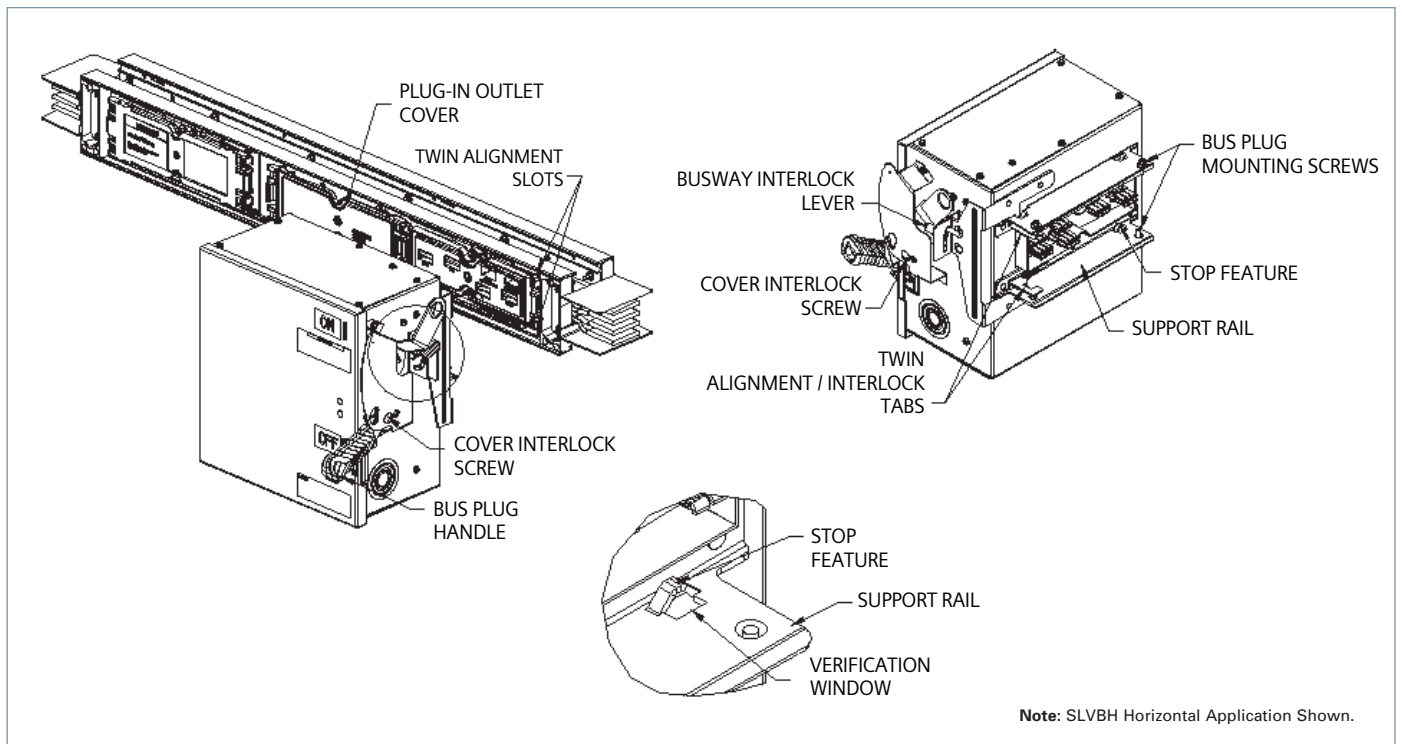

<sup>①</sup> Contact Siemens for 200% Neutral Applications.  
<sup>②</sup> IP55 enclosure not available.

# Sentron Circuit Breaker Bus Plugs

Catalog Numbering System

Selection / Application

## Sentron Bus Plugs—Circuit Breaker (Installed)

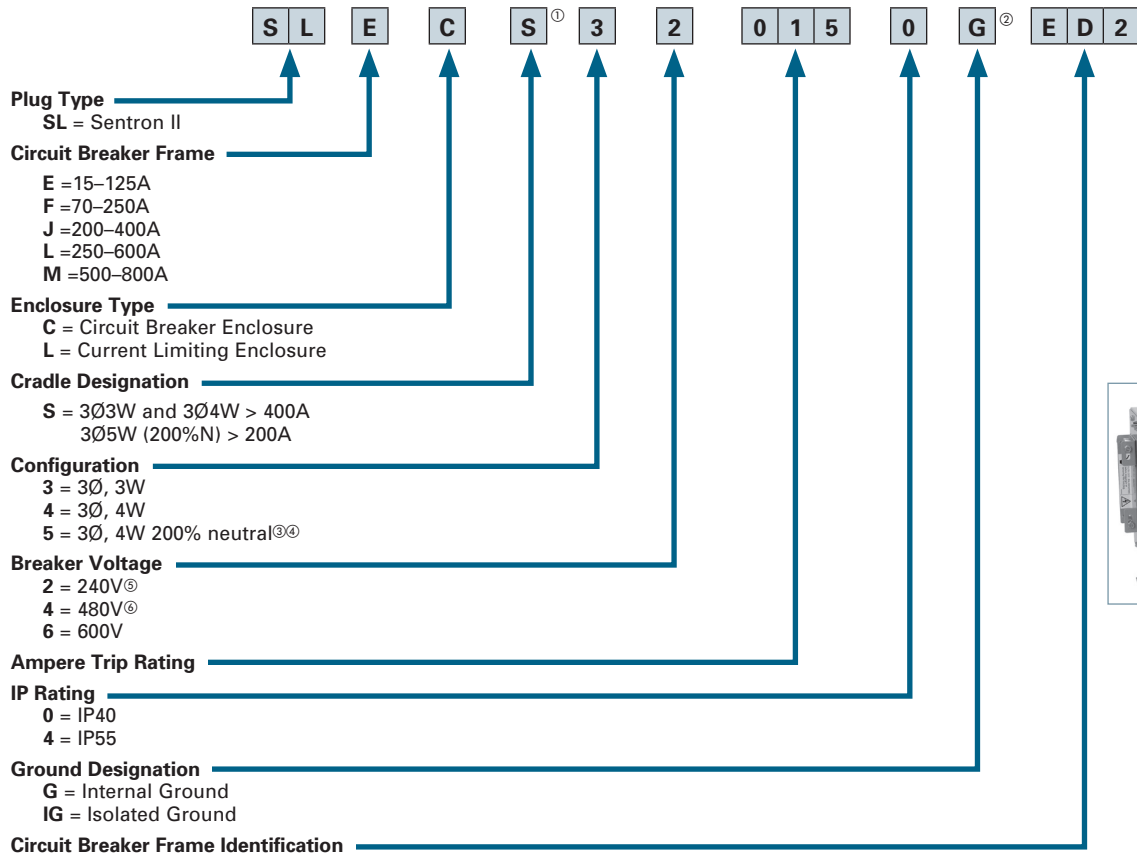

① The S digit is only used on 3- and 4-wire (100%N) plugs that are greater than 400A and 200%N plugs greater than 200A. Lower amperage plugs do not require this digit. (Ex. SLEC32060ED2)

② The G and IG digits are used to specify internal and isolated ground respectively. Integral (housing) ground plugs do not require this digit. (Ex. SLEC360150ED6)

③ Available through 250A only.

④ Available with E and F Frame breakers only.

⑤ Available with ED2 breakers only.

⑥ Available with ED4 and HHED6 breakers only.

# Sentron Bus Plugs

## Circuit Breaker Bus Plugs Dimensions and Weights

Overview

### Standard Circuit Breakers, Bus Plug Ratings<sup>①</sup>

Plug-In Units Series	Circuit Breaker Max. Rating	Frame Size	Max. Short Circuit Current Rating
SLEC	125A, 600V	E Frame	100kA, 240V, 3 ph 65kA, 480V, 3 ph <sup>①</sup> 25kA, 600V, 3 ph
SLFC	250A, 600V	F Frame	200kA, 240V, 3 ph 100kA, 480V, 3 ph 25kA, 600V, 3 ph
SLJC	400A, 600V	J Frame	200kA, 240V, 3 ph 100kA, 480V, 3 ph 50kA, 600V, 3 ph
SLLCS	600A, 600V	L Frame	200kA, 240V, 3 ph 100kA, 480V, 3 ph 50kA, 600V, 3 ph
SLMCS	800A, 600V	M Frame	200kA, 240V, 3 ph 100kA, 480V, 3 ph 65kA, 600V, 3 ph

### Current Limiting Circuit Breakers, Bus Plug Ratings<sup>①</sup>

Plug-In Units Series	Circuit Breaker Max. Rating	Frame Size	Max. Short Circuit Current Rating
SLEL	125A, 600V	CED Frame	200KA, 240V, 3 ph 200KA, 480V, 3 ph 100KA, 600V, 3 ph
SLFL	250A, 600V	CFD Frame	200KA, 240V, 3 ph 200KA, 480V, 3 ph 100KA, 600V, 3 ph
SLJL	400A, 600V	CJD Frame	200KA, 240V, 3 ph 150KA, 480V, 3 ph 100KA, 600V, 3 ph
SLLLS	600A, 600V	CLD Frame	200KA, 240V, 3 ph 150KA, 480V, 3 ph 100KA, 600V, 3 ph
SLMLS	800A, 600V	CMD Frame	200KA, 240V, 3 ph 100KA, 480V, 3 ph 65KA, 600V, 3 ph

Sentron Circuit Breaker Bus Plugs feature an easy to read “position indicator” label, designed to be visible from the floor, that clearly marks whether the bus plug is in the “Off,” “On,” or “Tripped” position. Circuit breaker bus plugs are available in frame sizes from 125 amps to 800 amps with interrupting ratings of standard, high or current limiting.

Circuit breaker bus plugs will be shipped complete with factory installed circuit breakers. The following Siemens molded case circuit breaker frames may be ordered with Sentron Circuit Breaker Bus Plugs: ED2, ED4, ED6, HED4, HHED6, CED6, FXD6, FD6, HFD6, CFD6 JXD6, JD6, HJD6, CJD6, LXD6, HLD6, CLD6, MXD6, HMD6, CMD6.

Refer to the diagram on page 15-44 for easy ordering instructions.

Sentron circuit breaker bus plugs can be custom configured to meet application specific requirements.

Consult your local Siemens sales office for details on custom pricing and ordering.

<sup>①</sup> Available in IP40 or IP55 variant.

# Sentron Circuit Breaker Bus Plugs

Bus Plugs with Standard Circuit Breakers<sup>①②③④</sup>

Selection

Ampere Rating	Catalog Number
<b>E Frame 3-Pole, 240 Volt, ED2 Breaker</b>	
15-60A	SLEC32***0ED2 SLEC32***0GED2 SLEC32***0IGED2
70-100A	SLEC32***0ED2 SLEC32***0GED2 SLEC32***0IGED2

Ampere Rating	Catalog Number
<b>E Frame 3-Pole, 480 Volt, ED4 Breaker</b>	
15-60A	SLEC34***0ED4 SLEC34***0GED4 SLEC34***0IGED4
70-100A	SLEC34***0ED4 SLEC34***0GED4 SLEC34***0IGED4
110-125A	SLEC34***0ED4 SLEC34***0GED4 SLEC34***0IGED4

Ampere Rating	Catalog Number
<b>E Frame 3-Pole, 600 Volt, ED6 Breaker</b>	
15-60A	SLEC36***0ED6 SLEC36***0GED6 SLEC36***0IGED6
70-100A	SLEC36***0ED6 SLEC36***0GED6 SLEC36***0IGED6
110-125A	SLEC36***0ED6 SLEC36***0GED6 SLEC36***0IGED6

Ampere Rating	Catalog Number
<b>F Frame 3-Pole, 600 Volt, FXD6 Breaker</b>	
70-225A	SLFC36***0FXD6 SLFC36***0GFXD6 SLFC36***0IGFXD6
250A	SLFC362500FXD6 SLFC362500GFXD6 SLFC362500IGFXD6

Ampere Rating	Catalog Number
<b>J Frame 3-Pole, 600 Volt, JXD6 Breaker</b>	
200-400A <sup>④</sup>	SLJC36***0JXD6 SLJC36***0GJXD6 SLJC36***0IGJXD6

Ampere Rating	Catalog Number
<b>L Frame 3-Pole, 600 Volt, LXD6 Breaker</b>	
450-600A <sup>④</sup>	SL LCS36***0LXD6 SL LCS36***0GLXD6 SL LCS36***0IGLXD6

Ampere Rating	Catalog Number
<b>M Frame 3-Pole, 600 Volt, MXD6 Breaker</b>	
500-800A <sup>④</sup>	SLMCS36***0MXD6 SLMCS36***0GMXD6 SLMCS36***0IGMXD6

Ampere Rating	Catalog Number	Ampere Rating	Catalog Number
<b>E Frame 4-Pole, 240 Volt, ED2 Breaker</b>		<b>E Frame 200% Neutral</b>	
15-60A	SLEC42***0ED2 SLEC42***0GED2 SLEC42***0IGED2	15-60A	SLEC52***0ED2 SLEC52***0GED2 SLEC52***0IGED2
70-100A	SLEC42***0ED2 SLEC42***0GED2 SLEC42***0IGED2	70-100A	SLEC52***0ED2 SLEC52***0GED2 SLEC52***0IGED2

Ampere Rating	Catalog Number	Ampere Rating	Catalog Number
<b>E Frame 4-Pole, 480 Volt, ED4 Breaker</b>		<b>E Frame 200% Neutral</b>	
15-60A	SLEC44***0ED4 SLEC44***0GED4 SLEC44***0IGED4	15-60A	SLEC54***0ED4 SLEC54***0GED4 SLEC54***0IGED4
70-100A	SLEC44***0ED4 SLEC44***0GED4 SLEC44***0IGED4	70-100A	SLEC54***0ED4 SLEC54***0GED4 SLEC54***0IGED4
110-125A	SLEC44***0ED4 SLEC44***0GED4 SLEC44***0IGED4	110-125A	SLEC54***0ED4 SLEC54***0GED4 SLEC54***0IGED4

Ampere Rating	Catalog Number	Ampere Rating	Catalog Number
<b>E Frame 4-Pole, 600 Volt, ED6 Breaker</b>		<b>E Frame 200% Neutral</b>	
15-60A	SLEC46***0ED6 SLEC46***0GED6 SLEC46***0IGED6	15-60A	SLEC56***0ED6 SLEC56***0GED6 SLEC56***0IGED6
70-100A	SLEC46***0ED6 SLEC46***0GED6 SLEC46***0IGED6	70-100A	SLEC56***0ED6 SLEC56***0GED6 SLEC56***0IGED6
110-125A	SLEC46***0ED6 SLEC46***0GED6 SLEC46***0IGED6	110-125A	SLEC56***0ED6 SLEC56***0GED6 SLEC56***0IGED6

Ampere Rating	Catalog Number	Ampere Rating	Catalog Number
<b>F Frame 4-Pole, 600 Volt, FXD6 Breaker</b>		<b>F Frame 200% Neutral</b>	
70-225A	SLFC46***0FXD6 SLFC46***0GFXD6 SLFC46***0IGFXD6	70-200A	SLFC56***0FXD6 SLFC56***0GFXD6 SLFC56***0IGFXD6
250A	SLFC462500FXD6 SLFC462500GFXD6 SLFC462500IGFXD6	225-250A	SLFC56***0FXD6 SLFC56***0GFXD6 SLFC56***0IGFXD6

Ampere Rating	Catalog Number
<b>J Frame 4-Pole, 600 Volt, JXD6 Breaker</b>	
200-400A <sup>④</sup>	SLJC46***0JXD6 SLJC46***0GJXD6 SLJC46***0IGJXD6

Ampere Rating	Catalog Number
<b>L Frame 4-Pole, 600 Volt, LXD6 Breaker</b>	
450-600A <sup>④</sup>	SL LCS46***0LXD6 SL LCS46***0GLXD6 SL LCS46***0IGLXD6

Ampere Rating	Catalog Number
<b>M Frame 4-Pole, 600 Volt, MXD6 Breaker</b>	
500-800A <sup>④</sup>	SLMCS46***0MXD6 SLMCS46***0GMXD6 SLMCS46***0IGMXD6

Description	Catalog Number
Spring Kit	SXSK

NOTE: Used on 400A and larger bus plugs that require auxiliary support and that are mounted on vertical/riser busway. Kit contains two springs (part number 32-9909-04). One kit required per bus plug. Spring kits are automatically included when 400A and larger bus plug is selected.

① Replace "\*\*\*\*" with breaker trip rating. Example: SLEC36060ED6, for 60A trip.  
 ② All plugs shown have an IP40 rating, if IP54/55 is desired substitute "4" for "0" in position 10 (or 11 for cradle plugs):  
 E Frame: Ex. SLEC360604ED6  
 F Frame: Ex. SLFC360704FXD6  
 J Frame: Ex. SLJC361004JXD6  
 L Frame: Ex. SL LCS365004LXD6  
 M Frame: Ex. SLMCS368004MXD6

③ For the following breaker substitutions, change the catalog number suffix:  
 15-60A: HHED6 Ex. SLEC36\*\*\*0HHED6  
 70-100A: HHED6 Ex. SLEC36\*\*\*0HHED6  
 110-125A: HHED6 Ex. SLEC36\*\*\*0HHED6  
 F Frame: FD6 Ex. SLFC36\*\*\*0FD6  
 F Frame: HFD6 Ex. SLFC36\*\*\*0HFD6  
 J Frame: JD6 Ex. SLJC36\*\*\*0JD6  
 J Frame: HJD6 Ex. SLJC36\*\*\*0HJD6  
 L Frame: LD6 Ex. SL LCS36\*\*\*0LD6  
 L Frame: HLD6 Ex. SL LCS36\*\*\*0HLD6  
 M Frame: MD6 Ex. SLMCS36\*\*\*0MD6  
 M Frame: HMD6 Ex. SLMCS36\*\*\*0HMD6

④ 400A and larger bus plugs that require auxiliary support. See also SXSK Spring Kit.

# Sentron Circuit Breaker Bus Plugs

Bus Plugs with Current Limiting Circuit Breakers<sup>①②</sup>

Selection

Ampere Rating	Catalog Number
---------------	----------------

## E Frame 3-Pole, 600 Volt, CED6 Breaker

15-60A	SLEL36***0CED6 SLEL36***0GCEd6 SLEL36***0IGCEd6
70-100A	SLEL36***0CED6 SLEL36***0GCEd6 SLEL36***0IGCEd6
110-125A	SLEL36***0CED6 SLEL36***0GCEd6 SLEL36***0IGCEd6

## F Frame 3-Pole, 600 Volt, CFD6 Breaker

100-225A	SLFL36***0CFD6 SLFL36***0GCFD6 SLFL36***0IGCFD6
250A	SLFL362500CFD6 SLFL362500GCFD6 SLFL362500IGCFD6

## J Frame 3-Pole, 600 Volt, CJD6 Breaker

200-400A <sup>③</sup>	SLJL36***0CJD6 SLJL36***0GCJD6 SLJL36***0IGJD6
-----------------------	--

## L Frame 3-Pole, 600 Volt, CLD6 Breaker

450-600A <sup>③</sup>	SLLS36***0CLD6 SLLS36***0GCLD6 SLLS36***0IGCLD6
-----------------------	---

## M Frame 3-Pole, 600 Volt, CLD6 Breaker

500-800A <sup>③</sup>	SLLS36***0CMD6 SLLS36***0GCMD6 SLLS36***0IGCMD6
-----------------------	---

Ampere Rating	Catalog Number
---------------	----------------

## E Frame 4-Pole, 600 Volt, CED6 Breaker

15-60A	SLEL46***0CED6 SLEL46***0GCEd6 SLEL46***0IGCEd6
70-100A	SLEL46***0CED6 SLEL46***0GCEd6 SLEL46***0IGCEd6
110-125A	SLEL46***0CED6 SLEL46***0GCEd6 SLEL46***0IGCEd6

## F Frame 4-Pole, 600 Volt, CFD6 Breaker

100-225A	SLFL46***0CFD6 SLFL46***0GCFD6 SLFL46***0IGCFD6
250A	SLFL462500CFD6 SLFL462500GCFD6 SLFL462500IGCFD6

## J Frame 4-Pole, 600 Volt, CJD6 Breaker

200-400A <sup>③</sup>	SLJL46***0CJD6 — SLJL46***0GCJD6 — SLJL46***0IGJD6 —
-----------------------	--

## L Frame 4-Pole, 600 Volt, CLD6 Breaker

450-600A <sup>③</sup>	SLLS46***0CLD6 SLLS46***0GCLD6 SLLS46***0IGCLD6
-----------------------	---

## M Frame 4-Pole, 600 Volt, CLD6 Breaker

500-800A <sup>③</sup>	SLLS46***0CMD6 SLLS46***0GCMD6 SLLS46***0IGCMD6
-----------------------	---

Ampere Rating	Catalog Number
---------------	----------------

## E Frame 200% Neutral

15-60A	SLEL56***0CED6 SLEL56***0GCEd6 SLEL56***0IGCEd6
70-100A	SLEL56***0CED6 SLEL56***0GCEd6 SLEL56***0IGCEd6
110-125A	SLEL56***0CED6 SLEL56***0GCEd6 SLEL56***0IGCEd6

## F Frame 200% Neutral

70-200A	SLFL56***0CFD6 SLFL56***0GCFD6 SLFL56***0IGCFD6
225-250A	SLFL56***0CFD6 SLFL56***0GCFD6 SLFL56***0IGCFD6

## J Frame 200% Neutral

200A <sup>③</sup>	SLJL562000CJD6 SLJL562000GCJD6 SLJL562000IGJD6
225-400A <sup>③</sup>	SLJL56***0CJD6 SLJL56***0GCJD6 SLJL56***0IGJD6

① Replace "\*\*\*\*" with breaker trip rating.  
Example: SLEC36060ED6, for 60A trip.

② All plugs shown have an IP40 rating, if IP54/55 is desired, substitute "4" for "0" in position 10 (or 11 for cradle plugs):

E Frame: Ex. SLEC360604ED6  
F Frame: Ex. SLFC360704FXD6  
J Frame: Ex. SLJC361004JXD6  
L Frame: Ex. SLLC365004LXD6  
M Frame: Ex. SLMCS368004MXD6

③ 400A and larger bus plugs that require auxiliary support. See also SXSK Spring Kit.

# Sentron Circuit Breaker Bus Plugs

## Circuit Breaker Bus Plugs Dimensions and Weights

Selection

### Circuit Breaker Bus Plugs, Dimensions and Weights (Enclosure only)

Ampere Rating	Dimensions Inches (mm)								Weight lbs (kg)
	"A" <sup>①</sup>	"B"	"C"	"D" max.	"E"	"F"	"J"	"K"	
125	15.13 (384)	10.18 (259)	9.75 (248)	1.60 (41)	2.50 (64)	2.50 (64)	3.50 (89)	2.25 (57)	35 (15.87)
250	20.25 (514)	10.18 (259)	9.75 (248)	1.60 (41)	2.50 (64)	2.50 (64)	3.25 (83)	3.25 (83)	50 (22.68)
400	21.75 (552)	16.75 (425)	11.75 (298)	1.60 (41)	5.75 (146)	5.75 (146)	4.00 (102)	3.25 (83)	83 (37.64)
600	41.50 (1054)	19.75 (502)	15.75 (400)	2.31 (59)	7.00 (178)	7.75 (197)	—	—	130 (58.97)
800	41.50 (1054)	19.75 (502)	15.75 (400)	2.31 (59)	7.00 (178)	7.75 (197)	—	—	177 (80.29)

#### 125 – 400A Bus Plugs

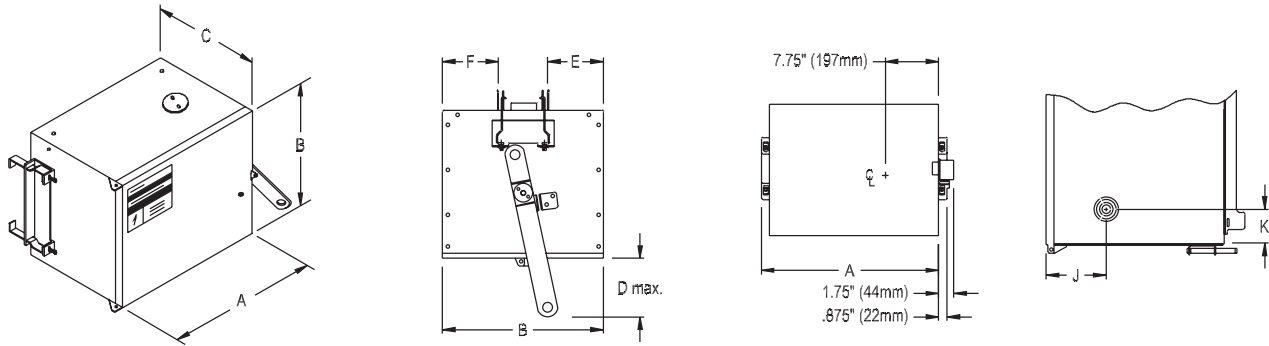

#### 600 – 800A Bus Plugs

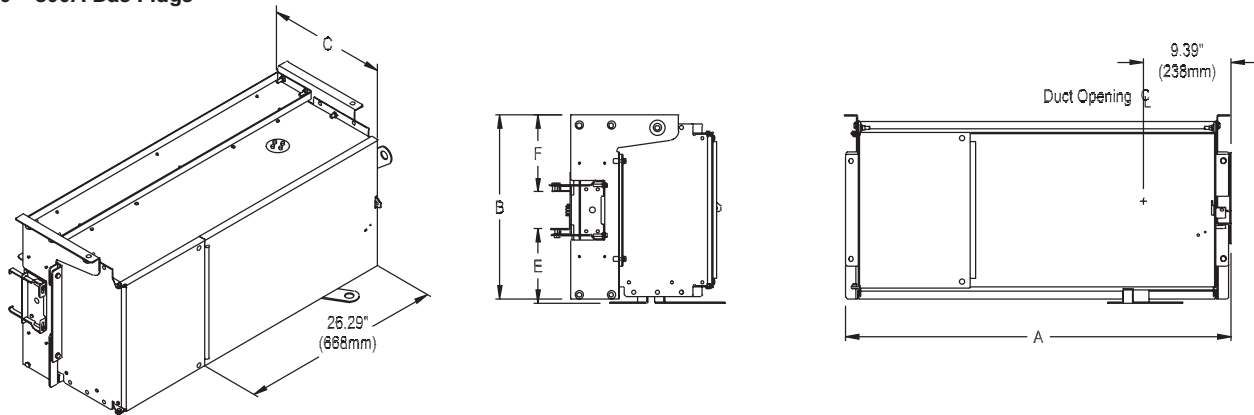

### Circuit Breaker Bus Plugs, Load Lugs and Knockouts

Frame Size	Ground Lug Cu/Al	Neutral Lug Cu/Al	Phase Lug Cu/Al	Knockout Sizes In. (mm)
E Frame	#14-2	#14-2	#14-1/0	7/8 (22)
F Frame	#14-2	#6-350 kcmil	#6-350 kcmil	7/8 (22)
J Frame	#14-2	(2) #4-500 kcmil	(2) 3/0-500 kcmil	7/8 (22)
L Frame	#6-350 kcmil	(2) 3/0-500 kcmil	(2) 3/0-500 kcmil	No Knockouts
M Frame	#4-500 kcmil	(3) #1-500 kcmil	(3) #1-500 kcmil	No Knockouts

① Current limiting breakers add 5-7 inches to dimension A, depending upon breaker amperage.



# Sentron Circuit Breaker Bus Plugs

## Wall Clearance and Circuit Breaker Bus Plug Dimensions

Selection

### 600A and 800A Cradle Mounted

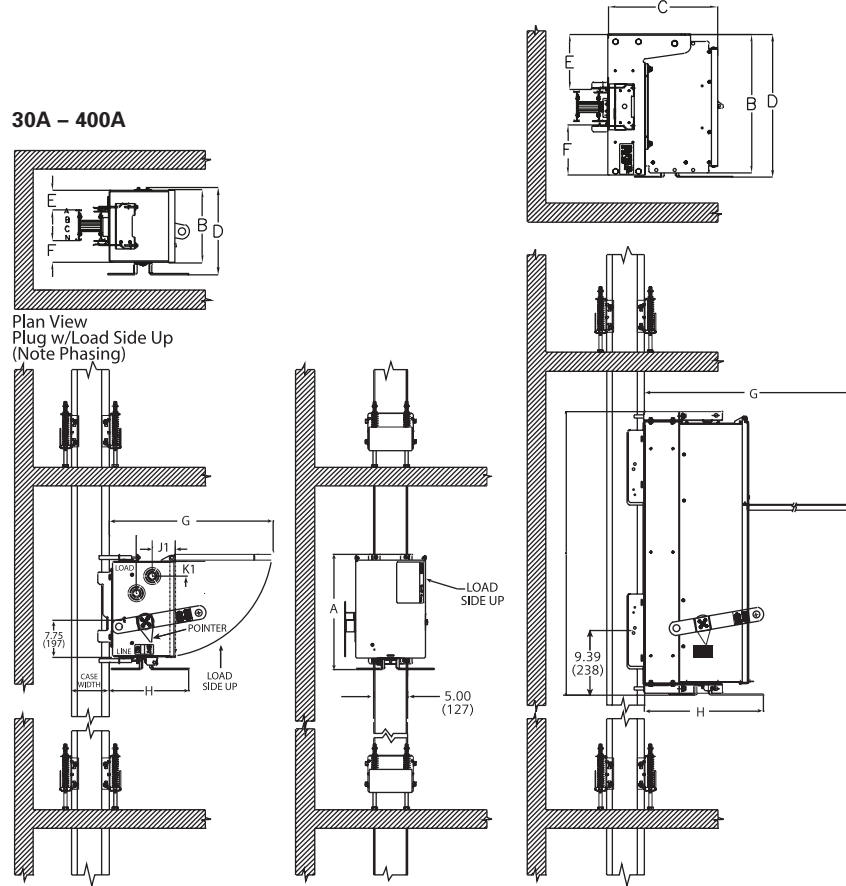

Dim. Legend	Circuit Breaker Plugs No Cradle						Circuit Breaker Plugs w/Cradle			
	E Frame Current		F Frame Current		J Frame Current		L Frame Current		M Frame Current	
	Standard	Limiting	Standard	Limiting	Standard	Limiting	Standard	Limiting	Standard	Limiting
A	17.00 (432)	22.00 (559)	22.00 (559)	27.00 (686)	23.50 (597)	30.50 (775)	41.50 (1054)	41.50 (1054)	41.50 (1054)	41.50 (1054)
B	10.25 (260)	10.25 (260)	10.25 (260)	10.25 (260)	16.75 (425)	16.75 (425)	19.75 (502)	19.75 (502)	19.75 (502)	19.75 (502)
C	9.75 (248)	9.75 (248)	9.75 (248)	9.75 (248)	11.75 (298)	11.75 (298)	15.75 (400)	15.75 (400)	15.75 (400)	15.75 (400)
D	12.25 (311)	12.25 (311)	12.25 (311)	12.25 (311)	18.75 (476)	18.75 (476)	20.25 (514)	20.25 (514)	20.25 (514)	20.25 (514)
E	2.50 (64)	2.50 (64)	2.50 (64)	2.50 (64)	5.75 (146)	5.75 (146)	7.75 (197)	7.75 (197)	7.75 (197)	7.75 (197)
F	2.50 (64)	2.50 (64)	2.50 (64)	2.50 (64)	5.75 (146)	5.75 (146)	7.00 (178)	7.00 (178)	7.00 (178)	7.00 (178)
G	24.00 (610)	29.00 (737)	29.00 (737)	29.00 (737)	32.50 (826)	39.50 (1003)	41.50 (1054)	41.50 (1054)	41.50 (1054)	41.50 (1054)
H	11.25 (286)	11.25 (286)	11.25 (286)	11.25 (286)	13.50 (343)	13.50 (343)	18.00 (457)	18.00 (457)	18.00 (457)	18.00 (457)
J1	3.50 (89)	3.50 (89)	3.25 (83)	3.25 (83)	4.00 (102)	4.00 (102)	—	—	—	—
K1	2.25 (57)	2.25 (57)	3.25 (83)	3.25 (83)	3.25 (83)	3.25 (83)	—	—	—	—

- Legend:
- A = Length of enclosure including handle
  - B = Height of enclosure
  - C = Depth of enclosure
  - D = Height of enclosure including optional handle location
  - E = Extension of plug above top of busway
  - F = Extension of plug below bottom of busway
  - G = Cover (depth) clearance for enclosure
  - H = Depth of enclosure from handle to edge of busway
  - J = Knockout/ pilot hole location (horizontal)
  - K = Knockout/ pilot hole location (vertical)

# Sentron Fusible Bus Plugs

Catalog Numbering System

Selection / Application

## Sentron SLVB Bus Plugs—Fusible

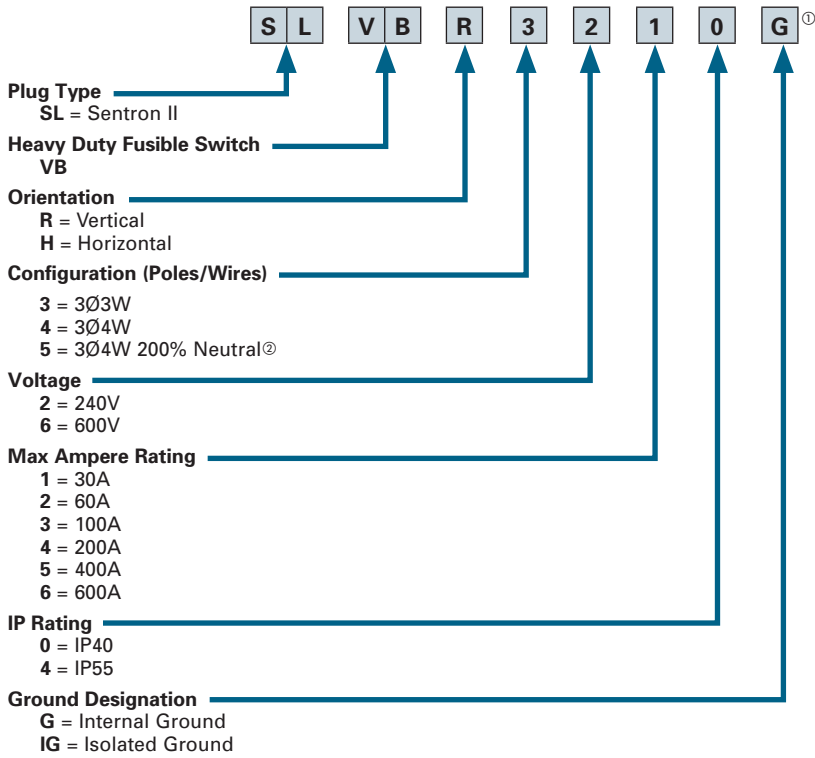

Watch SLVB Bus Plug installation video



① The G and IG digits are used to specify internal and isolated ground respectively. Integral (housing) ground plugs do not require this digit. (Ex. SLID3610, SLEC360150ED6)

Ⓞ Available through 400A only.

# Sentron Busway Systems

## Fusible Bus Plugs

## Selection

### Fusible Bus Plugs

The Sentron SLVB Bus Plug meets all UL and CSA standards to assure reliable performance in all environments. The installer and end user will appreciate new features like Highly Visible Position Indicator, Dual Stab Busway Interlocks, Dual Cover Interlocks, and Bolt-on Mounting.

Sentron SLVB Fusible Bus Plugs are available in 30, 60, 100, 200, 400 and 600 amp ratings (compatible with H, R, T, K and J fuses).



### Standard Fusible, Bus Plug Ratings

Plug-In Units Series	Max. Rating Fused Switch	Fuse Class	Fuse Kits		Max. Short Circuit Current Rating
			R Fuse Kits	T Fuse Kits	
SLVB_21	30A, 240V	H, K, R	SLR2030	—	200kA, 240V, 3ph
SLVB_61	30A, 600V	H, K, R, J	SLR6030	—	200kA, 600V, 3ph
SLVB_22	60A, 240V	H, K, R	SLR2060	—	200kA, 240V, 3ph
SLVB_62	60A, 600V	H, K, R, J	SLR6060	—	200kA, 600V, 3ph
SLVB_23	100A, 240V	H, K, R, J, T	SLR2100	SLT2100	200kA, 240V, 3ph
SLVB_63	100A, 600V	H, K, R, J, T	SLR6100	SLT6100	200kA, 600V, 3ph
SLVB_24	200A, 240V	H, K, R, J, T	SLR2200	SLT2200	200kA, 240V, 3ph
SLVB_64	200A, 600V	H, K, R, J, T	SLR6200	SLT6200	200kA, 600V, 3ph
SLVB_25	400A, 240V	H, K, R, J, T	SLR2400	SLT2400	200kA, 240V, 3ph
SLVB_65	400A, 600V	H, K, R, J, T	SLR6400	SLT6400	200kA, 600V, 3ph
SLVB_26	600A, 240V	H, K, R, J, T	SLR2600	SLT2600	200kA, 240V, 3ph
SLVB_66	600A, 600V	H, K, R, J, T	SLR6600	SLT6600	200kA, 600V, 3ph

### Standard Fusible, Bus Plug Horsepower Ratings

Plug-In Units Series	Fused Switch Max. Rating	240V, 1 ph		240V, 3 ph		480V, 3 ph		600V, 3 ph	
		Std.	Max.	Std.	Max.	Std.	Max.	Std.	Max.
SLVB_21	30A, 240V	1.5	3.0	3.0	7.5	—	—	—	—
SLVB_61	30A, 600V	—	—	—	—	5.0	15.0	7.5	20.0
SLVB_22	60A, 240V	3.0	10.0	7.5	15.0	—	—	—	—
SLVB_62	60A, 600V	—	—	—	—	15.0	30.0	15.0	50.0
SLVB_23	100A, 240V	7.5	15.0	15.0	30.0	—	—	—	—
SLVB_63	100A, 600V	—	—	—	—	25.0	60.0	30.0	75.0
SLVB_24	200A, 240V	15.0	—	25.0	60.0	—	—	—	—
SLVB_64	200A, 600V	—	—	—	—	50.0	125.0	60.0	150.0
SLVB_25	400A, 240V	15.0	—	50.0	125.0	—	—	—	—
SLVB_65	400A, 600V	—	—	—	—	100.0	250.0	125.0	350.0
SLVB_26	600A, 240V	15.0	—	75.0	200.0	—	—	—	—
SLVB_66	600A, 600V	—	—	—	—	150.0	400.0	200.0	500.0

# Sentron Fusible Bus Plugs

## Bus Plugs / Fusible Plugs

Selection

Ampere Rating	Catalog Number
---------------	----------------

### 3-Pole, 250 Volt<sup>①</sup>

30A	SLVB*3210 SLVB*3210G SLVB*3210IG
60A	SLVB*3220 SLVB*3220G SLVB*3220IG
100A	SLVB*3230 SLVB*3230G SLVB*3230IG
200A	SLVB*3240 SLVB*3240G SLVB*3240IG
400A <sup>②</sup>	SLVB*3250 SLVB*3250G SLVB*3250IG
600A <sup>②</sup>	SLVB*3260 SLVB*3260G SLVB*3260IG

Ampere Rating	Catalog Number
---------------	----------------

### 3-Pole, 600 Volt<sup>①</sup>

30A	SLVB*3610 SLVB*3610G SLVB*3610IG
60A	SLVB*3620 SLVB*3620G SLVB*3620IG
100A	SLVB*3630 SLVB*3630G SLVB*3630IG
200A	SLVB*3640 SLVB*3640G SLVB*3640IG
400A <sup>②</sup>	SLVB*3650 SLVB*3650G SLVB*3650IG
600A <sup>②</sup>	SLVB*3660 SLVB*3660G SLVB*3660IG

Ampere Rating	Catalog Number	Catalog Number
---------------	----------------	----------------

### 4-Pole, 250 Volt,<sup>①</sup>

### 200% Neutral<sup>①</sup>

30A	SLVB*4210 SLVB*4210G SLVB*4210IG	SLVB*5210 SLVB*5210G SLVB*5210IG
60A	SLVB*4220 SLVB*4220G SLVB*4220IG	SLVB*5220 SLVB*5220G SLVB*5220IG
100A	SLVB*4230 SLVB*4230G SLVB*4230IG	SLVB*5230 SLVB*5230G SLVB*5230IG
200A	SLVB*4240 SLVB*4240G SLVB*4240IG	SLVB*5240 SLVB*5240G SLVB*5240IG
400A <sup>②</sup>	SLVB*4250 SLVB*4250G SLVB*4250IG	SLVB*5250 SLVB*5250G SLVB*5250IG
600A <sup>②</sup>	SLVB*4260 SLVB*4260G SLVB*4260IG	

Ampere Rating	Catalog Number	Catalog Number
---------------	----------------	----------------

### 4-Pole, 600 Volt,<sup>①</sup>

### 200% Neutral<sup>①</sup>

30A	SLVB*4610 SLVB*4610G SLVB*4610IG	SLVB*5610 SLVB*5610G SLVB*5610IG
60A	SLVB*4620 SLVB*4620G SLVB*4620IG	SLVB*5620 SLVB*5620G SLVB*5620IG
100A	SLVB*4630 SLVB*4630G SLVB*4630IG	SLVB*5630 SLVB*5630G SLVB*5630IG
200A	SLVB*4640 SLVB*4640G SLVB*4640IG	SLVB*5640 SLVB*5640G SLVB*5640IG
400A <sup>②</sup>	SLVB*4650 SLVB*4650G SLVB*4650IG	SLVB*5650 SLVB*5650G SLVB*5650IG
600A <sup>②</sup>	SLVB*4660 SLVB*4660G SLVB*4660IG	

Note: Replace \* in catalog number with "H" for horizontal applications and "R" for riser applications.

## Ground Detector And Potentializer Plug

Description	Catalog Number
For 2 or 3-pole 240 and 480 volt service.	SLPGR3140G

Note: Available in IP40 construction only.

Description	Catalog Number
Spring Kit	SXSK

Note: Used on 400A and larger bus plugs that require auxiliary support and that are mounted on vertical/riser busway. Kit contains two springs (part number 32-9909-04). One kit required per bus plug. Spring kits are automatically included when 400A and larger bus plug is selected.

## Fuse Adapter Kits

Switch Rating	Std Fuse Class	Class R Catalog Number	Class T Catalog Number	Class J Catalog Number
---------------	----------------	------------------------	------------------------	------------------------

### 250V

30A <sup>③</sup>	H, K	SLR2030		
60A <sup>③</sup>	H, K	SLR2060		
100A <sup>③</sup>	H, K	SLR2100	SLT2100	
200A <sup>③</sup>	H, K	SLR2200	SLT2200	
400A <sup>②</sup>	H, K, J	SLR2400	SLT2400	
600A <sup>②</sup>	H, K, J	SLR2600	SLT2600	SLJ2600

### 600V

30A <sup>③</sup>	H, K, J	SLR6030		
60A <sup>③</sup>	H, K, J	SLR6060		
100A <sup>③</sup>	H, K, J	SLR6100	SLT6100	
200A <sup>③</sup>	H, K, J	SLR6200	SLT6200	
400A <sup>②</sup>	H, K, J	SLR6400	SLT6400	
600A <sup>②</sup>	H, K, J	SLR6600	SLT6600	SLJ6600

① All plugs shown are rated IP40; if IP55 rating is desired, substitute a "4" for "0" in position 9.

② 400A and larger bus plugs require auxiliary support. See also SXSK Spring Kit.

# Sentron Fusible Bus Plugs

## Fusible Bus Plugs Dimensions and Weights

Selection

### Horizontal Fusible Bus Plug Dimensions and Weights (Enclosure Only)

Ampere Rating	Dimensions Inches (mm)												Weight lbs (kg)
	"A"	"B"	"C"	"D max."	"E"	"F"	"J"	"K"	"L"	"M"	"N"	"P"	
30	13.13 (333)	13.86 (352)	7.96 (202)	2.60 (66)	6.18 (156)	2.66 (67)	2.65 (67)	2.06 (52)	9.81 (249)	6.22 (157)	5.27 (134)	8.59 (218)	23.5 (10.66)
60	13.13 (333)	14.86 (377)	7.96 (202)	2.60 (66)	7.18 (182)	2.66 (67)	2.65 (67)	2.06 (52)	9.81 (249)	6.22 (157)	5.27 (134)	9.59 (244)	25.5 (11.56)
100	13.13 (333)	15.86 (402)	7.96 (202)	2.60 (66)	8.18 (207)	2.66 (67)	2.65 (67)	2.06 (52)	9.81 (249)	6.22 (157)	5.27 (134)	10.59 (269)	28.0 (12.70)
200	14.88 (377)	22.86 (580)	10.58 (268)	2.60 (66)	15.88 (403)	2.66 (67)	3.40 (86)	3.06 (78)	9.81 (249)	7.95 (201)	5.27 (134)	17.59 (447)	49.0 (22.22)
400	18.63 (473)	25.48 (647)	15.67 (398)	5.50 (140)	12.67 (322)	7.67 (195)	12.15 (309)	3.06 (78)	11.80 (299)	9.43 (239)	11.91 (303)	15.14 (385)	100.0 (254)
600	18.63 (473)	25.48 (647)	15.67 (398)	5.50 (140)	12.67 (322)	7.67 (195)	12.15 (309)	3.06 (78)	11.80 (299)	9.43 (239)	11.91 (303)	15.14 (385)	100.0 (254)

Watch SLVB Bus Plug installation video

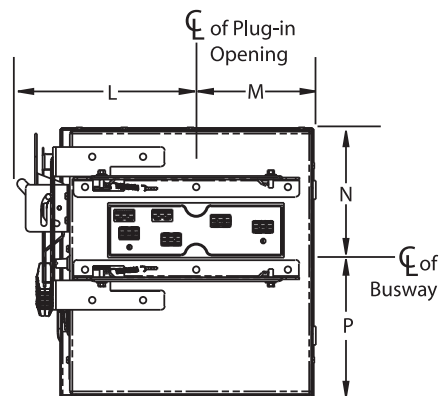
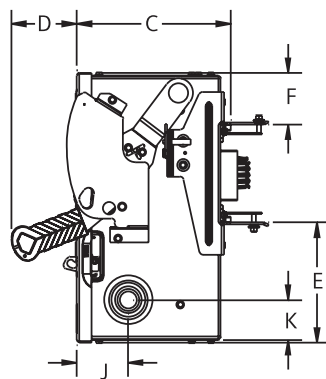
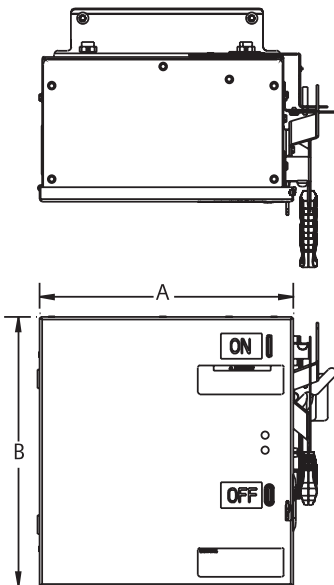
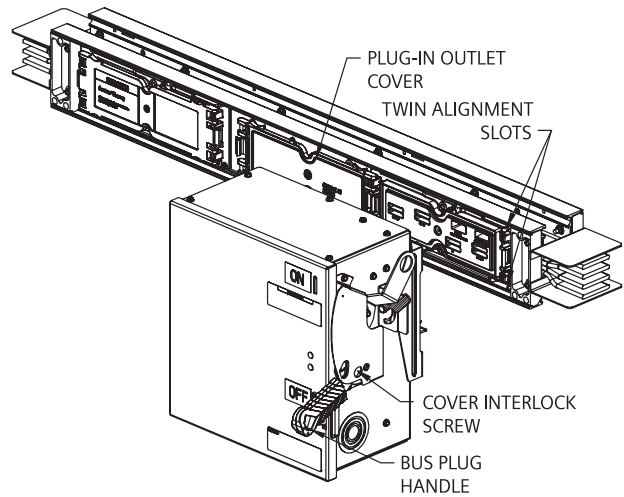

# Sentron Fusible Bus Plugs

## Fusible Bus Plugs Dimensions and Weights

Selection

### Riser Fusible Bus Plug Dimensions and Weights (Enclosure Only)

Ampere Rating	Dimensions Inches (mm)												Weight lbs (kg)
	"A"	"B"	"C"	"D max."	"E"	"F"	"J"	"K"	"L"	"M"	"N"	"P"	
30	10.13 (257)	13.86 (352)	7.96 (202)	5.25 (133)	2.74 (69)	2.36 (59)	2.65 (67)	2.06 (52)	8.06 (204)	5.08 (129)	7.8 (198)	6.06 (154)	23.5 (10.66)
60	10.13 (257)	14.86 (377)	7.96 (202)	5.25 (133)	2.74 (69)	2.36 (59)	2.65 (67)	2.06 (52)	8.06 (204)	2.08 (52)	7.8 (198)	7.06 (179)	25.5 (11.56)
100	11.13 (282)	15.86 (402)	7.96 (202)	5.25 (133)	7.74 (196)	3.36 (85)	2.65 (67)	2.06 (52)	8.06 (204)	6.08 (154)	7.8 (198)	8.06 (205)	28.0 (12.70)
200	14.88 (377)	22.86 (580)	10.58 (268)	5.90 (149)	5.11 (129)	4.74 (120)	3.40 (86)	3.06 (78)	10.42 (264)	7.35 (186)	9.05 (230)	13.81 (351)	49.0 (22.22)
400	18.63 (473)	25.48 (647)	15.67 (398)	5.50 (140)	6.60 (167)	7.10 (180)	12.15 (309)	3.06 (78)	11.97 (304)	9.25 (234)	13.56 (344)	13.49 (342)	100.0 (2540)
600	18.63 (473)	25.48 (647)	15.67 (398)	5.50 (140)	6.60 (167)	7.10 (180)	12.15 (309)	3.06 (78)	11.97 (304)	9.25 (234)	13.56 (344)	13.49 (342)	100.0 (2540)

Watch SLVB Bus Plug installation video

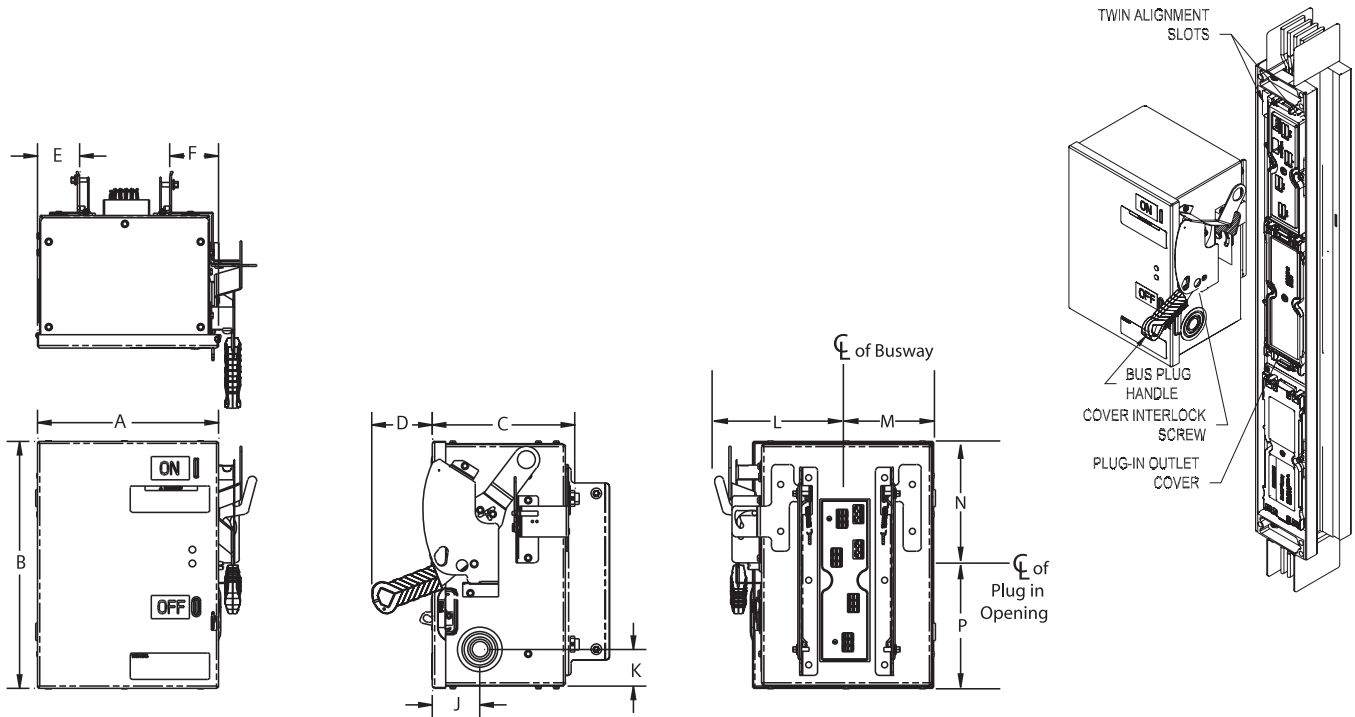

### Fusible Switch Plug, Load Lugs, and Knockouts

Ampere Rating	Ground Lug Cu/Al	Neutral Lug Cu/Al	Phase Lug Cu/Al	Knockout Sizes Inches (mm)
30	#14-1/0	#14-2	#14-2	7/8 (22)
60	#14-1/0	#14-1/0	#14-2	7/8 (22)
100	#14-1/0	#14-1/0	#14-1/0	7/8 (22)
200	#14-1/0	#6-300MCM	#6-300MCM	7/8 (22)
400	(2)#6-350MCM	(2) 1/0-250MCM or (1) 1/0-750MCM	(2) 1/0-250MCM or (1) 1/0-750MCM	7/8 (22)
600	(2)#6-350MCM	(4) 1/0-250MCM or (2) 1/0-750MCM	(4) 1/0-250MCM or (2) 1/0-750MCM	7/8 (22)



# Sentron Fusible Bus Plugs

## Wall Clearance and Fusible Bus Plug Dimensions

Dimensions

### Wall Clearance and Bus Plug Dimensions Horizontal (Inches/mm)

Dim.	30	60	100	200	400	600
A	13.13 (333)	13.13 (333)	13.13 (333)	14.88 (377)	18.63 (473)	18.63 (473)
B	13.86 (352)	14.86 (377)	15.86 (402)	22.86 (580)	27.00 (686)	27.00 (686)
C	7.96 (202)	7.96 (202)	7.96 (202)	10.58 (268)	15.67 (398)	15.67 (398)
D	15.89 (403)	16.68 (423)	17.68 (449)	24.66 (626)	20.00 (508)	20.00 (508)
E	6.19 (157)	7.19 (182)	8.19 (208)	15.19 (385)	12.67 (322)	12.67 (322)
F	2.67 (67)	2.67 (67)	2.67 (67)	2.67 (67)	7.67 (195)	7.67 (195)
G	20.39 (517)	20.39 (517)	20.39 (517)	24.76 (628)	33.75 (857)	33.75 (857)
H	13.09 (332)	13.09 (332)	13.09 (332)	16.55 (420)	21.17 (538)	21.17 (538)
J	2.65 (67)	2.65 (67)	2.65 (67)	3.40 (86)	12.15 (309)	12.15 (309)
K	2.06 (52)	2.06 (52)	2.06 (52)	3.06 (78)	3.06 (78)	3.06 (78)
L	2.65 (67)	2.65 (67)	2.65 (67)	2.65 (67)	2.65 (67)	2.65 (67)
M	15.07 (382)	15.07 (382)	15.07 (382)	16.82 (427)	21.00 (533)	21.00 (533)

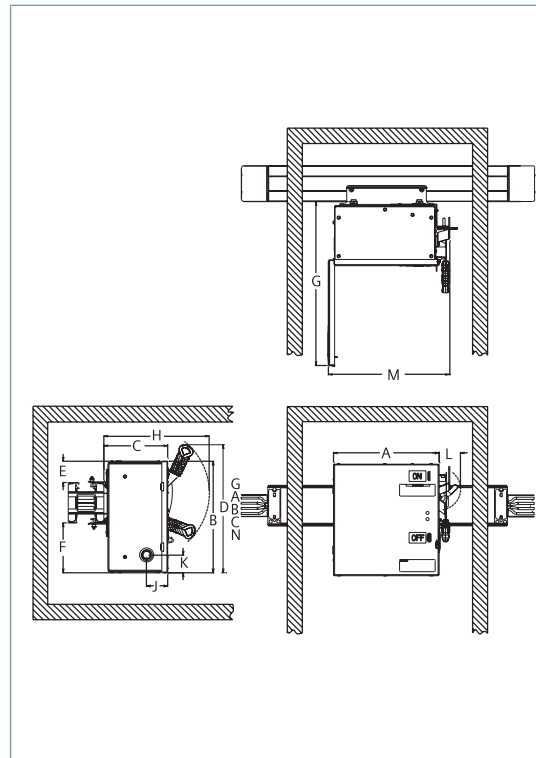

Watch SLVB  
Bus Plug  
installation  
video



### Wall Clearance and Bus Plug Dimensions Riser (Inches/mm)

Dim.	30	60	100	200	400	600
A	10.13 (237)	10.13 (257)	11.13 (282)	14.68 (372)	18.63 (473)	18.63 (473)
B	13.86 (352)	14.86 (377)	15.86 (402)	22.86 (580)	27.00 (686)	27.00 (686)
C	7.96 (202)	7.96 (202)	7.96 (202)	10.58 (268)	15.67 (398)	15.67 (398)
D	15.89 (403)	16.68 (423)	17.68 (449)	24.66 (626)	20.00 (508)	20.00 (508)
E	2.74 (69)	2.74 (69)	7.74 (196)	5.11 (129)	6.60 (167)	6.60 (167)
F	2.36 (59)	2.36 (59)	3.36 (85)	4.74 (120)	7.10 (180)	7.10 (180)
G	17.39 (441)	17.39 (441)	18.39 (467)	24.76 (628)	33.75 (857)	33.75 (857)
H	13.09 (332)	13.09 (332)	13.09 (332)	16.55 (420)	21.17 (538)	21.17 (538)
J	2.65 (67)	2.65 (67)	2.65 (67)	3.40 (86)	12.15 (309)	12.15 (309)
K	2.06 (52)	2.06 (52)	2.06 (52)	3.06 (78)	3.06 (78)	3.06 (78)
L	3.55 (90)	3.55 (90)	3.55 (90)	3.55 (90)	2.65 (67)	2.65 (67)
M	12.07 (306)	12.07 (306)	13.07 (331)	16.82 (427)	21.00 (533)	21.00 (533)

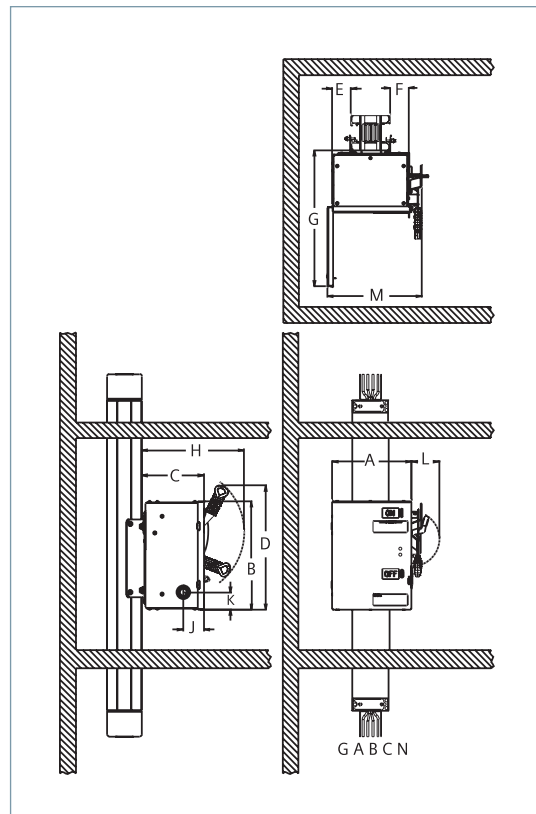

# Sentron SPD Bus Plugs

Sentron SPD Bus Plugs

Technical

## The Siemens advantage...

Siemens history of innovation and safety continues with our line of UL 1449 4th Edition SPD's. The TPS Series utilizes thermally protected MOV's specifically designed for safe operation in high fault current or sustained overvoltage conditions that can cause other SPD's to fail in an unsafe manner and damage other equipment in the distribution system. Every MOV, including N-G, is monitored. Indicator lights for each phase provide indication of loss of protection and phase loss protection. The direct bus, integral design reduces circuit impedance resulting in the lowest possible let-through voltages providing maximum protection to facility equipment and systems.

### All TPS Series SPD's:

- UL 1449 4th Edition Listed, CUL, CE Mark
- Designed, tested, manufactured to ANSI/IEEE C62.42.1 – 2002, C62.41.2 – 2002, C62.45 – 2002
- Provide indication of loss of protection on each phase and phase loss
- Include all UL-required over current protection and safety coordination inside
- Prevent internally generated surges from propagating throughout a facility and externally generated surges from reaching sensitive loads

### Low Exposure Applications – TPS3 09

- 100kA per phase
- 200kA SCCR
- 20kA nominal discharge current
- Indicator lights standard
- Individually fused, thermally protected MOV's
- Dry contacts and audible alarm optional

### Medium Exposure Applications – TPS3 01

- 100kA – 300kA per phase
- 200kA SCCR
- 20kA nominal discharge current
- Indicator lights, audible alarm and dry contacts standard
- Individually fused, thermally protected MOV's
- EMI/RFI filtering
- Surge counter optional

### High Exposure Applications – TPS3 06

- 400kA – 500kA per phase
- 200kA SCCR
- 20kA nominal discharge current
- Indicator lights, audible alarm and dry contacts standard
- Individually fused, thermally protected MOV's
- EMI/RFI filtering
- Surge counter optional

Watch SLVB  
Bus Plug  
installation  
video



# Sentron SPD Bus Plugs

## Sentron SPD Bus Plug Numbering System

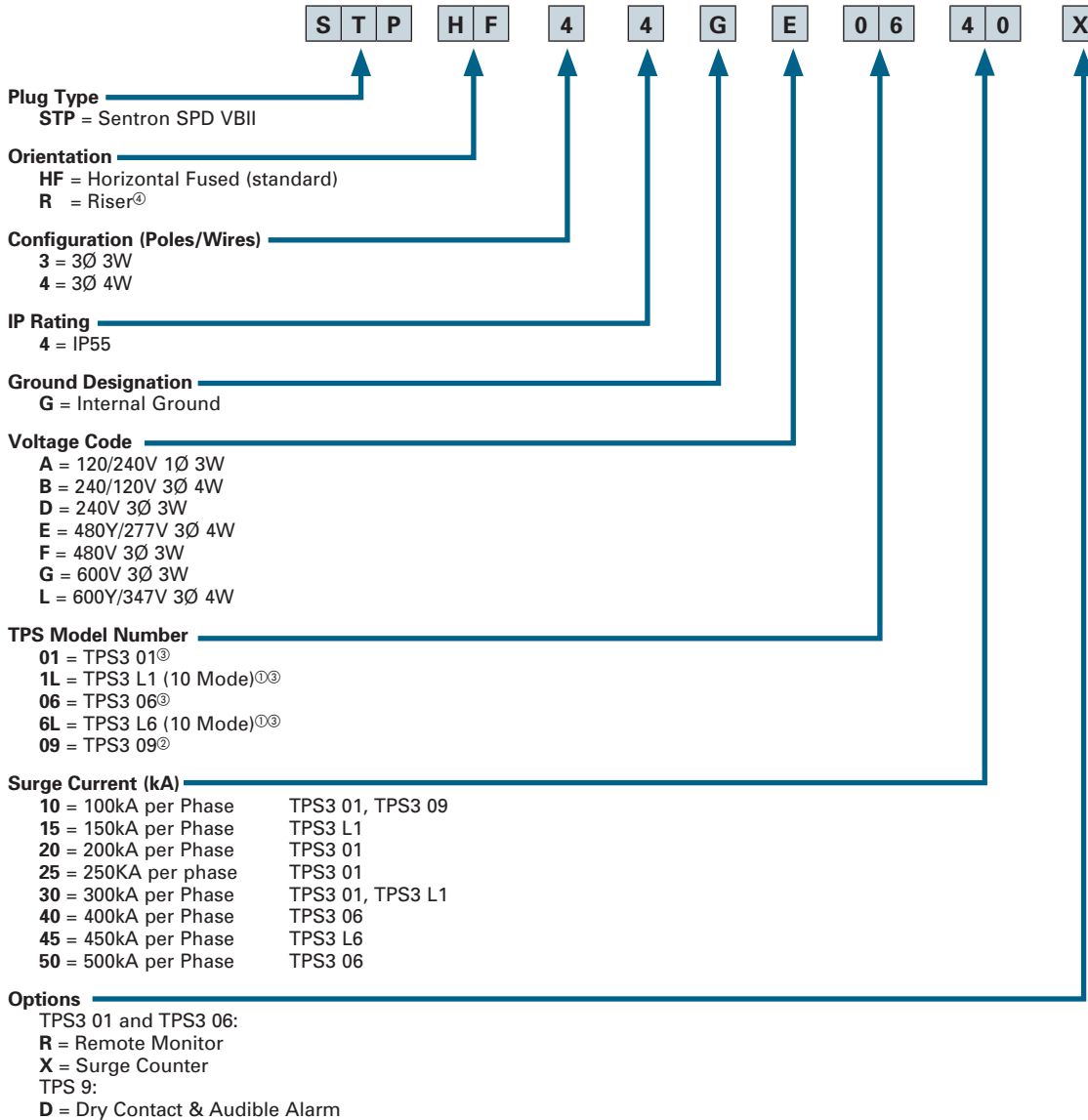

Watch SLVB Bus Plug installation video



Notes:  
 Ⓞ The 10 mode devices provide additional circuit protection for Line to Neutral and Neutral to Ground. The 10 modes of protection are: L1-G, L2-G, L3-G, L1-L2, L2-L3, L1-L3, L1-N, L2-N, L3-N, N-G.  
 Ⓞ Standard features: indicator lights.  
 Ⓞ Standard features: indicator lights, dry contacts, audible alarm with silence switch, test button.  
 Ⓞ In riser applications, Sentron SPD Bus Plug Numbering System only requires the "R" character.

# Sentron SPD Bus Plugs

Sentron SPD Bus Plugs

Technical

## Horizontal SPD bus plugs dimensions and weights

Plug type	Dimensions inches (mm)						Weight lbs. (kgs)
	"A"	"B"	"C"	"D" max.	"E"	"F"	
TPS 9	13.30 (336)	15.86 (403)	7.44 (189)	2.60 (66)	8.17 (208)	2.66 (67)	30 (13.63)
TPS 1	19.30 (490)	11.77 (299)	8.50 (216)	2.60 (66)	4.08 (104)	2.66 (67)	35 (15.90)
TPS 6	19.30 (490)	11.77 (299)	8.50 (216)	2.60 (66)	4.08 (104)	2.66 (67)	38 (17.27)

Watch SLVB Bus Plug installation video

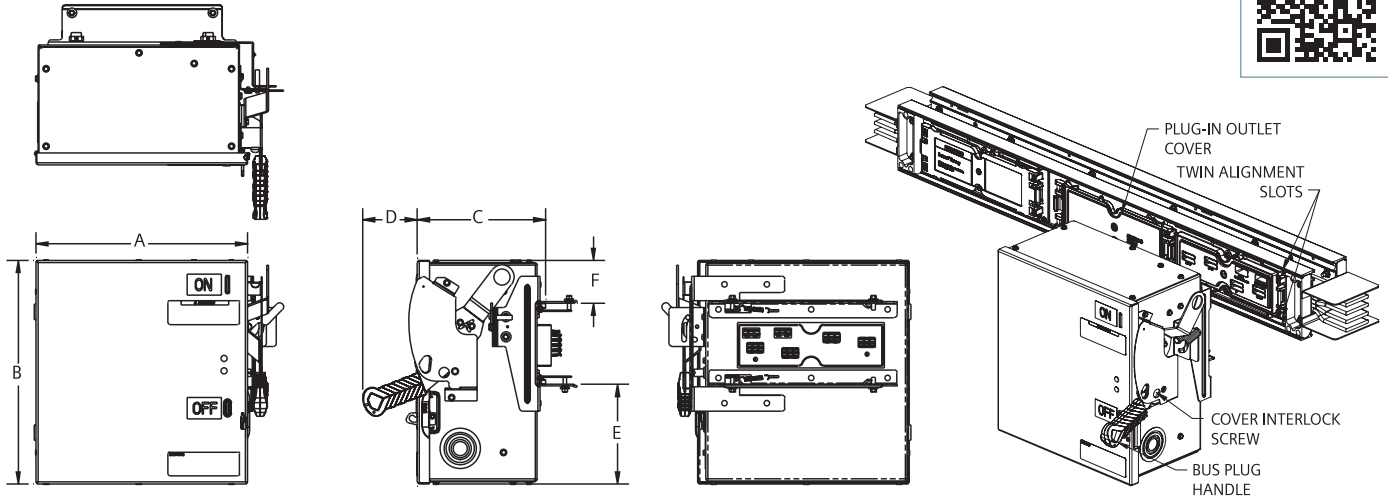

## Riser SPD bus plugs dimensions and weights

Plug type	Dimensions inches (mm)						Weight lbs. (kgs)
	"A"	"B"	"C"	"D" max.	"E"	"F"	
TPS 9	10.25 (260)	13.86 (352)	7.96 (202)	5.25 (133)	2.74 (69)	2.36 (59)	25 (11.36)
TPS 1	11.25 (286)	19.36 (492)	7.96 (202)	5.25 (133)	7.74 (196)	3.36 (85)	35 (15.90)
TPS 6	15.00 (381)	22.86 (580)	10.58 (268)	5.25 (133)	5.11 (129)	4.74 (120)	45 (20.45)

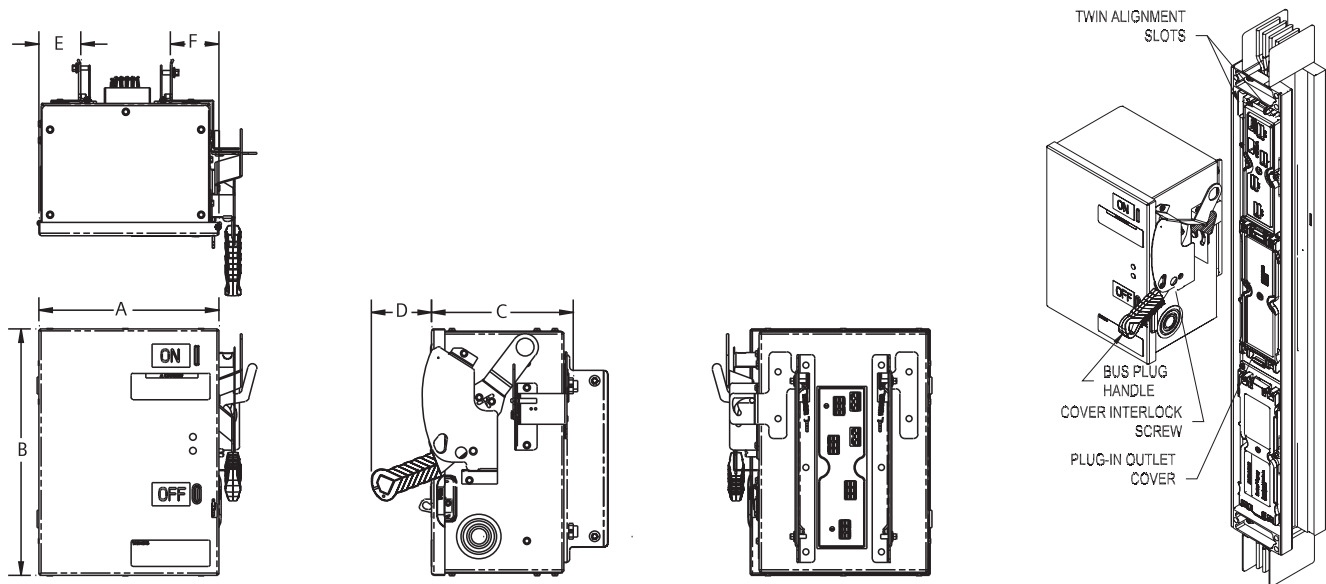

# Sentron 3/6 Bus Plugs

## Product Overview

The Sentron 3/6 bus plug is designed for light industrial, commercial, and datacenter applications. Optional factory installed receptacles range from 10 to 100A per pole, and the bus plug allows for anywhere between 1 and 6 poles of distribution (i.e. two 3Ø receptacles per plug). This product combines plug-and-play capabilities, minimizing installation time and cost, with the option for preconfigured embedded branch circuit metering utilizing SEM3™.

## Product Application

Building your metered network of Sentron 3/6 bus plugs is easy. There are two variations of metered bus plugs, simple meter plugs (child) and controller plugs (parent). Each SEM3™ controller can monitor 42 bus plug poles. Depending on the number of metered poles per bus plug, one parent controller plug can monitor between 6 to 41 bus plugs. An example of a network of seven 6-pole bus plugs is shown below (in this case there is one controller and six metered plugs). Outputs from multiple controller plugs may be consolidated at an Ethernet switch (shown below) or integrated directly into a building or site management system.

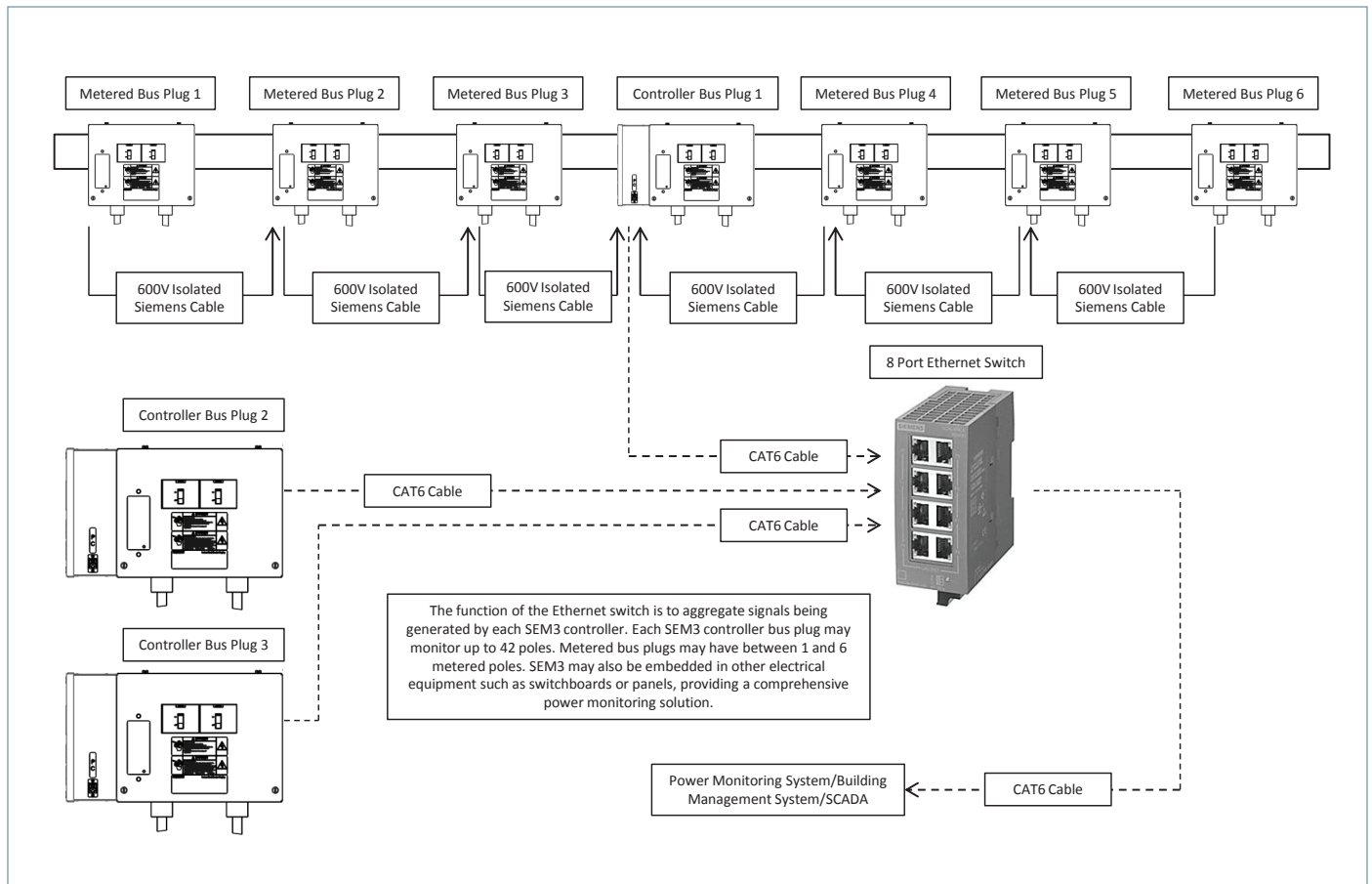

# Sentron 3/6 Bus Plugs

Catalog Numbering System

Selection / Application

## Sentron 3/6 Bus Plugs—Circuit Breaker (Installed)

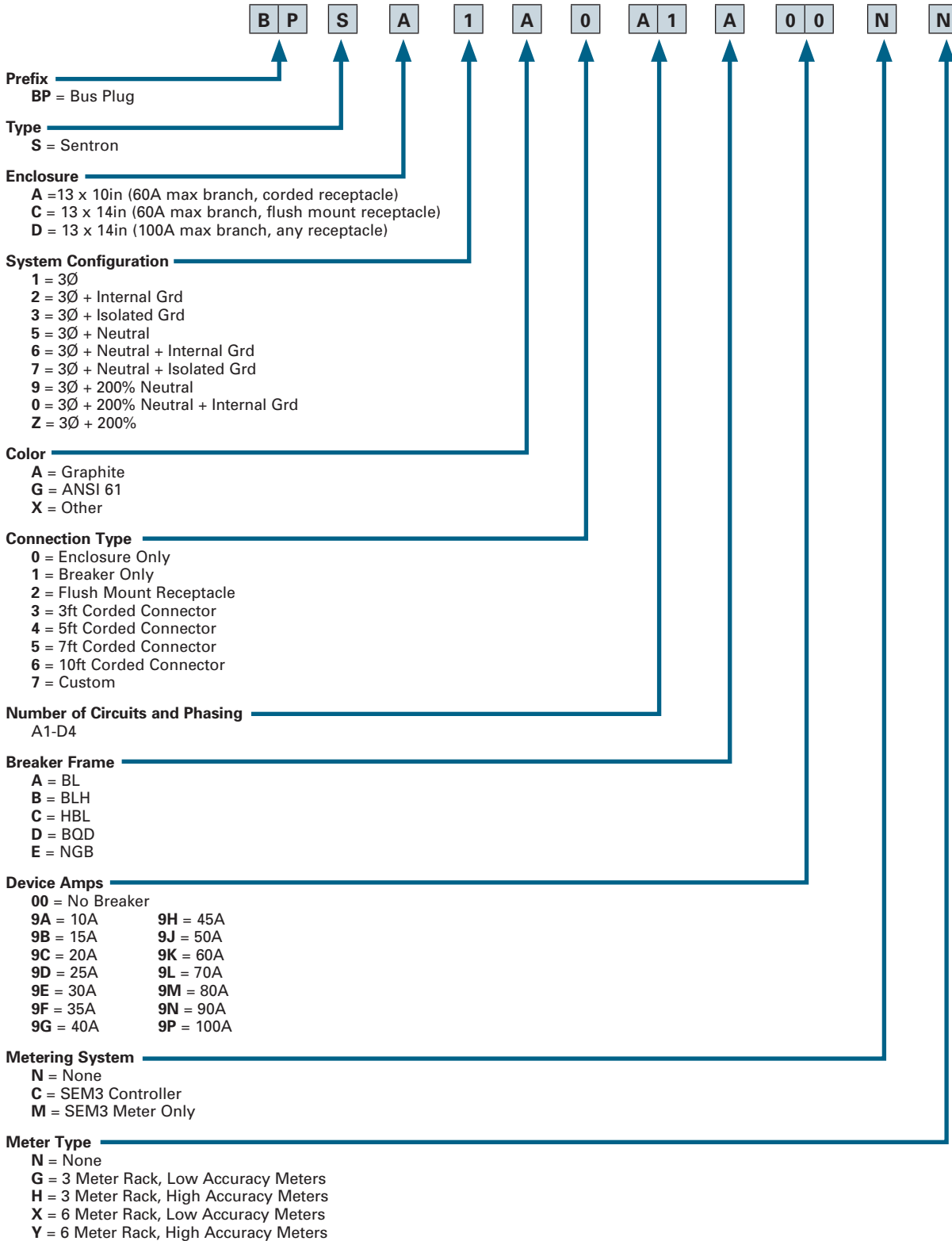



# Sentron 3/6 Bus Plugs

Sentron 3/6 Bus Plugs

Technical

## Product Configurations

### Field Wire-able Bus Plug

- Enclosure height of 14.20"
- Customer supplied receptacle or corded connector
- Stocking program for specific variants

### Non-Metered Bus Plug

- Standard enclosure height of 10.18" at 60A (per pole) and below
- Enclosure height of 14.20" for all surface mounted receptacle variants
- Factory installed corded or surface mount receptacles/connectors

### Metered Bus Plug

- Standard enclosure height of 10.18" at 60A (per pole) and below
- Enclosure height of 14.20" for all surface mounted receptacle variants
- Factory installed corded or surface mount receptacles/connectors
- Preconfigured SEM3 meter rack (child)

### Controller Bus Plug

- Standard enclosure height of 10.18" at 60A (per pole) and below
- Enclosure height of 14.20" for all surface mounted receptacle variants
- Factory installed corded or surface mount receptacles/connectors
- Preconfigured SEM3 meter rack and controller (parent)

## Product Configurations

<b>Circuit</b>	<ul style="list-style-type: none"> <li>• 1-6 poles of distribution</li> <li>• 10-100A per pole</li> <li>• 100 and 200% neutral options</li> </ul>
<b>Siemens Breaker Frames</b>	BL, BLH, HBL, BQD, NGB,
<b>Load Connection</b>	<ul style="list-style-type: none"> <li>• Field wired (with KO's), no receptacles</li> <li>• Surface or flush mount receptacles</li> <li>• Corded Connector(s) or receptacle(s) at 3, 5, 7, or 10 ft</li> </ul>
<b>Branch Circuit Metering (SEM3™)</b>	<ul style="list-style-type: none"> <li>• Meter only lug or meter and controller plug</li> <li>• 3 and 6 meter racks available</li> <li>• Low (1%) and high (.2%) accuracy meters available</li> </ul>

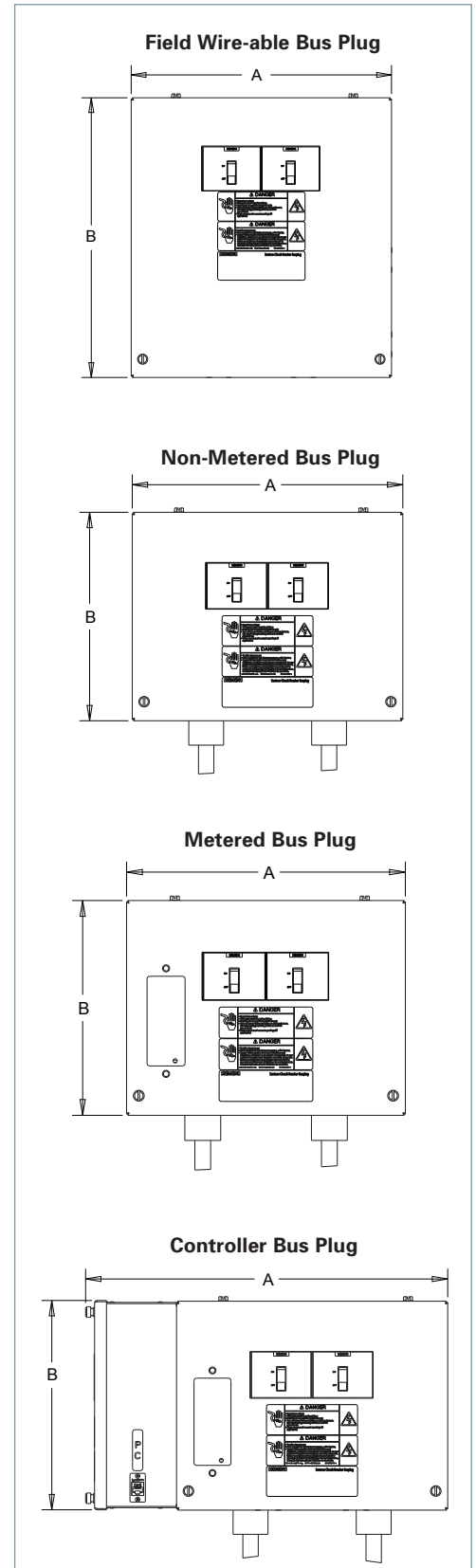

# Sentron 3/6 Bus Plugs

Sentron 3/6 Bus Plugs

Technical

## Corded Bus Plug (Non-Metered and Metered) Dimensions and Weights

Ampere Rating	Dimensions inches (mm)									Weight lbs. (kgs)*
	"A"	"B"	"C"	"D"	"E"	"F"	"G"	"H"	"I"	
10-60A	13.21 (336)	10.18 (259)	7.64 (194)	4.12 (105)	1.03 (26)	6.93 (176)	6.29 (160)	3.55 (90)	6.64 (169)	21 (9.52)
70-100A	13.21 (336)	14.20 (361)	7.64 (194)	8.12 (206)	1.03 (26)	6.93 (176)	6.29 (160)	3.55 (90)	10.64 (270)	23 (10.43)

\*Approximate weight without cord of heaviest plug in amperage range.

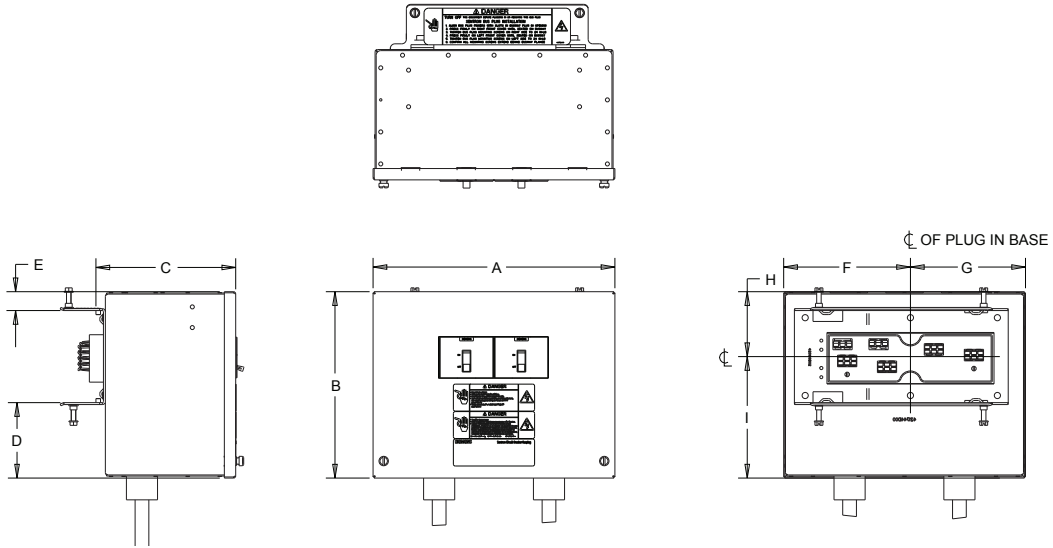

## Corded Bus Plug (Controller) Dimensions and Weights

Ampere Rating	Dimensions inches (mm)									Weight lbs. (kgs)*
	"A"	"B"	"C"	"D"	"E"	"F"	"G"	"H"	"I"	
10-60A	17.64 (448)	10.20 (259)	7.64 (194)	4.12 (105)	1.03 (26)	6.93 (176)	10.71 (272)	3.55 (90)	6.64 (169)	29 (13.15)
70-100A	17.64 (448)	14.20 (361)	7.64 (194)	8.12 (206)	1.03 (26)	6.93 (176)	10.71 (272)	3.55 (90)	10.64 (270)	31 (14.06)

\*Approximate weight without cord of heaviest plug in amperage range.

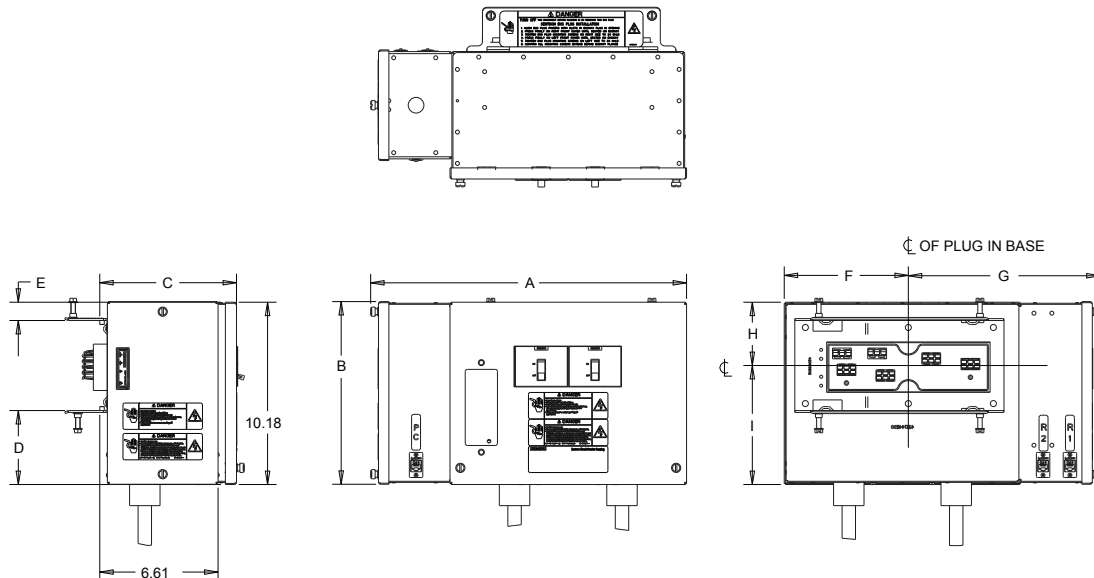

# Sentron 3/6 Bus Plugs

## Surface Mount Receptacle Bus Plug (Non-Metered and Metered) Dimensions and Weights

Ampere Rating	Dimensions inches (mm)									Weight lbs. (kgs)*
	"A"	"B"	"C"	"D"	"E"	"F"	"G"	"H"	"I"	
10-100A	13.21 (336)	14.20 (361)	7.64 (194)	8.12 (206)	1.03 (26)	6.93 (176)	6.29 (160)	3.55 (90)	10.64 (270)	23 (10.43)

\*Approximate weight without cord of heaviest plug in amperage range.

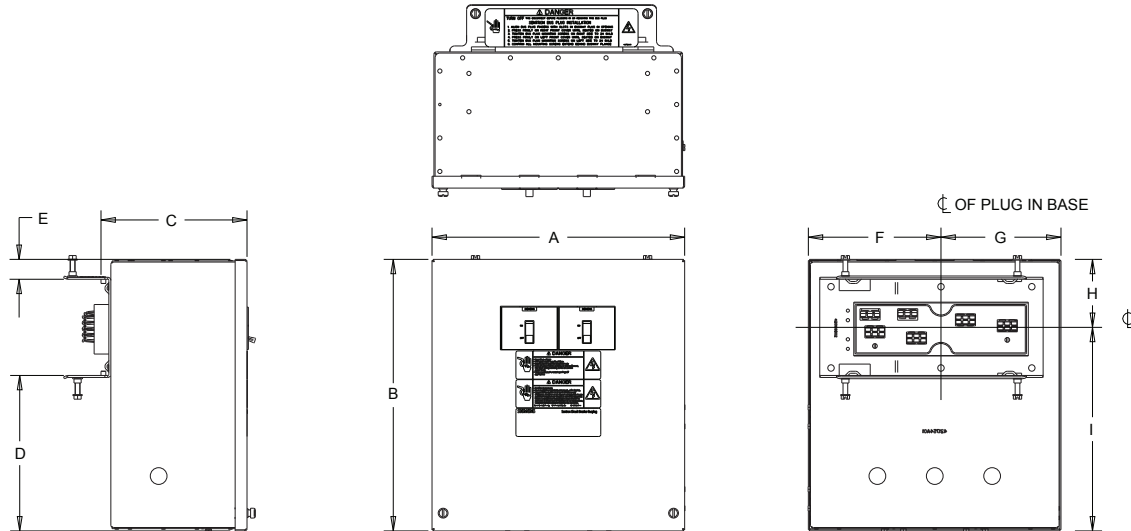

## Surface Mount Receptacle Bus Plug (Controller) Dimensions and Weights

Ampere Rating	Dimensions inches (mm)									Weight lbs. (kgs)*
	"A"	"B"	"C"	"D"	"E"	"F"	"G"	"H"	"I"	
10-100A	17.64 (448)	14.20 (361)	7.64 (194)	8.12 (206)	1.03 (26)	6.93 (176)	10.71 (272)	3.55 (90)	10.64 (270)	33 (14.97)

\*Approximate weight without cord of heaviest plug in amperage range.

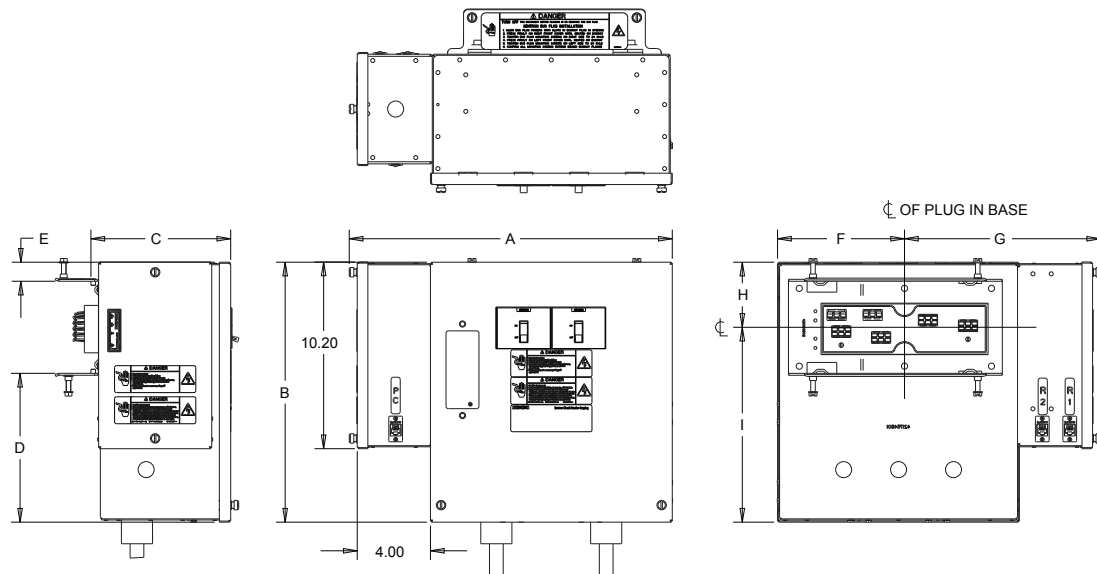

# XJ-L™ HD Busway System

## XJ-L HD Busway Introduction

XJ-L HD Busway is available up to 400A. XJ-L Busway is the leading power distribution solution for demanding applications that require reliable, high quality power. XJ-L HD Busway is the optimal choice for both contractors and users concerned with designing superior electrical systems that require a high plug density and optimal space utilization.

### Competitive advantages:

- Compact size – small cross section for applications where busway routing is constrained
- Joint Connection – dual spring clamp assemblies ensure reliable, maintenance-free joints
- Safety – plug-in outlets are IP2X finger safe
- Reliability – fundamental design has a 60 year history of reliability
- Service – simple snap together installation, maintenance free joints, factory stock of critical components and large distribution inventory of bus plugs ensure quick and easy serviceability
- Fittings – elbow, tee, crosses, flanged end, and tap boxes are offered in standard and custom configurations
- Compatibility – the full range of XJ-L HD bus plugs are interchangeable between 100A, 225A and 400A busway



### Key features:

- Up to twelve 100A bus plugs can be installed per 10' of plug-in busway. Plug-in busway can be configured with six plug-in openings per side (standard) or twelve on one side (high density).
- Bus plugs are readily installed on energized busway and are fully interchangeable between 100, 225 and 400A configurations.
- Bus plugs are available with fusible or circuit breaker disconnects, configured with a wide variety of optional receptacles, branch circuit breakers, drop cords, etc.
- Bus bars are solid copper (98% conductivity) and tin plated for superior electrical performance and corrosion resistance (optional silver plating is also available). The solid bus bar design provides superior short circuit strength (up to 35 kA) compared to channel style conductors and cable.
- Totally enclosed steel housing is robust, guarding against incidental contact and contamination of live parts. Enclosed box design will not twist or distort during bus plug installation.
- Installation is fast and easy. Joint connections simply snap together without special tools, housing couplers, or bus connectors.
- Suitable for horizontal and vertical mounting and under-the floor applications.

# XJ-L™ HD Busway System

## XJ-L HD Busway Overview

### XJ-L HD Busway

XJ-L HD Busway is well known for its outstanding performance, providing convenient, cost-effective power distribution for high-tech environments, data centers, laboratories, and other applications requiring consistent, quality power distribution. Key XJ-L HD design features include optional isolated ground or 200% neutral across entire product range.

As a result, XJ-L HD Busway is an intelligent choice for contractors and users concerned with designing superior electrical distribution systems. The compact design is ideal for limited working areas in critical power, manufacturing, laboratory test facilities, schools, hospitals, and machine shops.

With XJ-L HD Busway, you get an exclusive, optional isolated ground design that ensures clean power. Unlike bonded ground designs that may convey surges from one electrical device to another, the XJ-L HD optional isolated ground system is well suited for critical power environments. The ground bar is the same size as the phase bars, with the same ampere rating. Installation is easy, joining one XJ-L HD Busway section to another is as simple as matching ends and snapping them together. Bus bars are held securely in place by spring pressure clips located in the joint insulator. The joint is secured when the external housing plate is attached

with captive screws. Thanks to built-in flexibility and a low initial cost, you also benefit from future savings when you need new equipment.

Time to add on busway for new or expanded facilities? The XJ-L Busway you installed years ago matches the XJ-L HD Busway you specify today and years from now the new busway sections, components or system-compatible bus plugs will still fit.

### Dependability

With over one million feet in service, XJ-L HD Busway has a proven track record. The busway joints are easy to install and maintenance free. Solid copper bus bars and totally enclosed steel housings are designed for decades of dependable service.

### Flexibility

Siemens XJ-L HD Busway is available in a wide variety of straight lengths, elbows, tees, crosses, and tap boxes that can be installed and then readily expanded or reconfigured to meet changing requirements. Custom fittings and straight lengths can be engineered to tailor the busway system to application-specific customer requirements. Bus Plugs can be installed, then relocated as required without de-energizing the busway. All XJ-L HD Bus Plugs are fully interchangeable with all XJ-L HD Busway configurations.

### Cost

Siemens XJ-L HD Busway offers a lower cost solution, compared to cable and conduit, sandwich style busway or even light duty track busway. Snap together installation requires no special tools and is fast, easy and maintenance free. Solid, highly conductive bus bars minimize electrical losses and ensure long-term energy savings.

### Equipment protection

Critical equipment is protected via fuse or circuit breaker plugs. Due to their proximity, the plugs provide a localized method of protection and isolated disconnection.

### Space

Space in critical power/data center facilities is at a premium. XJ-L HD Busway requires less space than conventional power distribution methods such as cable and conduit.

### Availability

XJ-L HD plugs are stocked to meet your quick-ship requirements. Once you factor in all the advantages, XJ-L HD is clearly the best choice for reliable, flexible, and economical power distribution for data centers, light industrial, and high tech applications.





# XJ-L™ HD Busway System

## XJ-L HD Busway Specifications

XJ-L HD Busway is available in 100A, 225A and 400A ratings making it the right choice for light industrial and commercial applications where low initial startup and maintenance costs are pre-requisites. XJ-L HD Busway is the most logical choice for high tech, data intensive environments, especially when isolated ground is required.

### Housing

XJ-L HD Busway features a totally enclosed, non-ventilated, steel housing. The housing is covered with an electrostatically applied polyester urethane powder paint. Choice of colors: ASA#61 Gray or Graphite Gray. The paint is scratch resistant and has a 500 hour salt spray rating.

### Conductors

The conductors are fabricated from 98% conductivity copper. The bars are "spaced-in-air" and held securely in the housing by the plug-in outlets and joints.

### Neutral

100% neutral is available for standard 4 wire applications. A second neutral bar can be added for 200% neutral capacity.

Note: the 200% neutral bar can be utilized as Isolated Ground.

The internal ground bus is 100% rated for 100A, 60% rated for 225A, and 50% for 400A busway. Isolated ground is rated at 100% for both amperages.

### Plating

The entire length of the bus bar is tin plated to ensure good electrical contact at all joint and plug tap-off points. The plating also serves to protect the bars from corrosion. Optional silver plating is available.

### Plug-in base

XJ-L HD Busway features multiple plug-in locations. The plastic, non-tracking outlets are located on 20 or 9.75 inch centers and support the bus bars providing bracing during short circuit conditions. The plug-in outlets are IP2X (finger safe).

### Joint connection

Busway sections are connected via a maintenance-free, spring pressure joint. The busway ends are easily aligned and bus bar ends are held securely in place by spring pressure clips located in the joint insulator. The housings are connected via external housing plates and captive screws.

### Bus plugs

There are twelve plug-in outlets on each 10 foot (3.048 m) section, six openings on 5 foot (1.524 m) sections and two outlets on 2 foot (.616 m) sections. Bus plugs are available with amperages ranging from 15A to 100A. Bus plugs feature circuit breakers or fusible switch disconnects.

### Testing

Each piece of XJ-L HD Busway is factory tested prior to shipment. A dielectric test is performed to ensure product integrity. XJ-L HD Busway is manufactured and inspected in accordance to an ISO 9001 registered Quality Management System.

### Standards

XJ-L HD Busway products meet the following standards:  
UL 857  
NEMA BU1  
CSA C22.2

### Ratings

Amperage: 100A, 225A and 400A  
Voltage: 600 VAC max<sup>Ⓢ</sup>  
Short circuit: 100A – 10kAIC  
225A – 22kAIC  
400A – 35kAIC



<sup>Ⓢ</sup> 225A three phase four or five wire has 277/480V max

### R,X,Z and voltage drop

Ampere rating	Bus bar width x .125 in. (3.2 mm) thick	Ohm x 10 <sup>-3</sup> per 100 ft. Line to neutral			Voltage drop – concentrated loads, line-to-line per 100 ft. at 100% rated load, 35°C ambient power factor							
		R	X	Z	0.3	0.4	0.5	0.6	0.7	0.8	0.9	1.0
100	0.50 (13.0)	1.67	8.71	1.88	2.30	2.54	2.75	2.94	3.10	3.21	3.25	2.89
225	1.00 (25.4)	8.20	4.08	9.16	2.48	2.74	2.98	3.19	3.37	3.51	3.57	3.20
400	2.13 (54.1)	4.27	3.01	5.23	2.88	3.10	3.29	3.44	3.56	3.62	3.57	2.96



# XJ-L™ HD Busway System

## Straight Sections

### Plug-in section

Prefix	Type	Fitting Type			Amp	Configuration	Color	Plug-in Busway Only		
		1	2	0				Plug-In Location	Plug-In Spacing	
<b>BW</b>	<b>J</b>	<b>P</b>	<b>1</b>	<b>2</b>	<b>0</b>	<b>1</b>	<b>6</b>	<b>G</b>	<b>L</b>	<b>2</b>
XJ-L HD	↑	↑	Length: 024 = 24 inches 060 = 60 inches 120 = 120 inches			1 = 100 2 = 225 4 = 400	1 = 3Ø 2 = 3Ø + Internal Grd 3 = 3Ø + Isolated Grd 4 = 3Ø + Internal Grd + Isolated Grd 5 = 3Ø + Neutral 6 = 3Ø + Neutral + Internal Grd 7 = 3Ø + Neutral + Isolated Grd 8 = 3Ø + Neutral + Internal Grd + Isolated Grd 9 = 3Ø + 200% Neutral 0 = 3Ø + 200% Neutral + Internal Ground	A = Graphite G = ANSI 61 X = Other	L = Left Side Only R = Right Side Only S = Dual Side	1 = 20" Dual Side <sup>①</sup> 2 = 9.75" Single Side <sup>②</sup>
Plug-in	↑	↑	<b>Notes:</b> <sup>①</sup> Use for Plug-in Length = "S" <sup>②</sup> Use for Plug-in Length = "L" or "R"							

### Plug-in sections

Available in 10 foot (3.048 m), 5 foot (1.524 m) or 2 foot (.616 m) standard plug-in lengths, XJ-L HD Busway offers layout flexibility to meet custom requirements. Plug-in busway can be configured with six plug-in openings per side or twelve on one side.

### Feeder Section

Prefix	Type	Fitting Type			Amp	Configuration	Color	
		1	2	0				
<b>BW</b>	<b>J</b>	<b>F</b>	<b>1</b>	<b>2</b>	<b>0</b>	<b>1</b>	<b>6</b>	<b>G</b>
XJ-L HD	↑	↑	Length in inches, Ex. 2' 3" = 024 Feeder lengths available from 16" (016) up to 10' 0" (120)			1 = 100 2 = 225 4 = 400	1 = 3Ø 2 = 3Ø + Internal Grd 3 = 3Ø + Isolated Grd 4 = 3Ø + Internal Grd + Isolated Grd 5 = 3Ø + Neutral 6 = 3Ø + Neutral + Internal Grd 7 = 3Ø + Neutral + Isolated Grd 8 = 3Ø + Neutral + Internal Grd + Isolated Grd 9 = 3Ø + 200% Neutral 0 = 3Ø + 200% Neutral + Internal Ground	A = Graphite G = ANSI 61 X = Other
Feeder	↑	↑						

### Feeder Sections

Feeder busway carries the current of the busway system from the supply source. Feeder busway does not have plug-in outlets. Feeder busway is available in custom lengths from 16.00 in (406mm) to 120.00 in (3048mm). Feeder sections are available as Indoor.

XJ-L HD Busway also features an exclusive rotating cover plate to facilitate inspection of the joints. The light weight design of the busway and plugs makes the installation of XJ-L HD Busway quick and trouble-free.

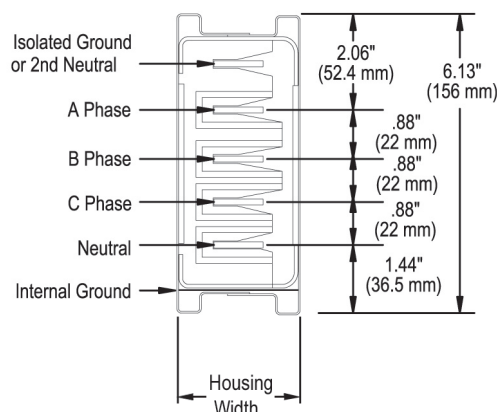

# XJ-L™ HD Busway System

## Straight Sections

### Plug-in Section (Dual Side)

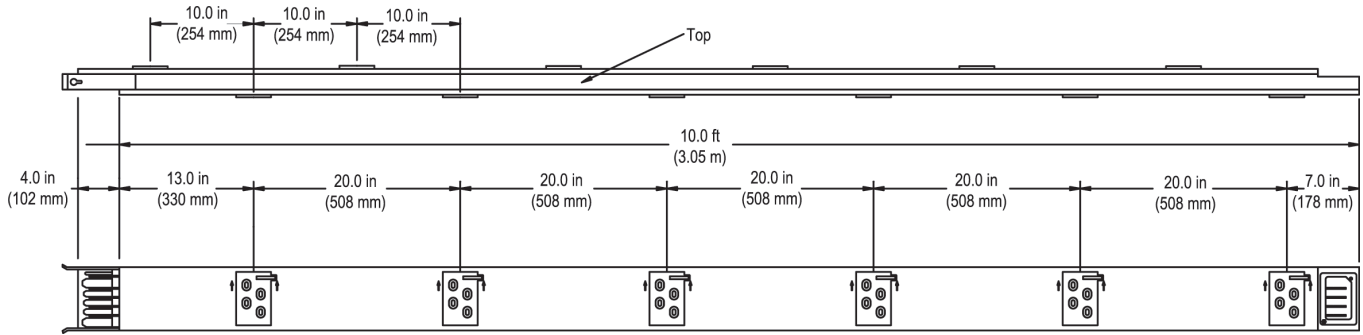

### Plug-in Section (Single Side-Right hand configuration shown)

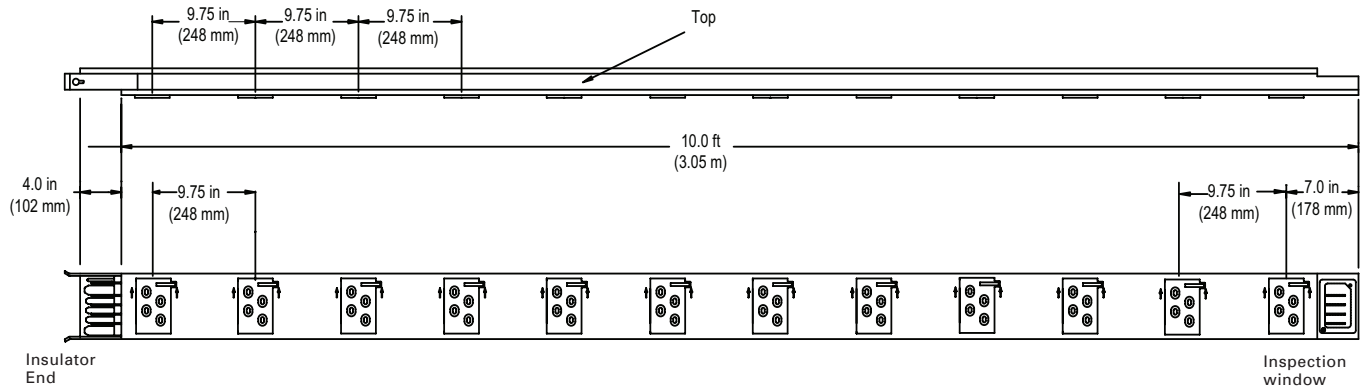

### Plug-in Section

Ampere Rating	Bus Bar Material	Bar Thickness	Bar Width	Housing Width	Housing Height	Max Voltage	Short Circuit Rating	Length Ft (M)	3 Pole		4 Pole	
									Model Number <sup>①</sup>	Wgt. (lb)	Model Number <sup>①</sup>	Wgt. (lb)
100	Copper	.125 (3.2)	.5 (13)	2.0 (51)	6.13 (156)	600V	10kA	10.0 (3.05)	BWJP12011GS1	42	BWJP12015GS1	45
100	Copper	.125 (3.2)	.5 (13)	2.0 (51)	6.13 (156)	600V	10kA	5.0 (1.52)	BWJP06011GS1	21	BWJP06015GS1	23
100	Copper	.125 (3.2)	.5 (13)	2.0 (51)	6.13 (156)	600V	10kA	2.0 (.61)	BWJP02411GS1	8	BWJP02415GS1	9
225	Copper	.125 (3.2)	1.0 (25)	2.5 (64)	6.13 (156)	600V	22kA	10.0 (3.05)	BWJP12021GS1	56	BWJP12025GS1	62
225	Copper	.125 (3.2)	1.0 (25)	2.5 (64)	6.13 (156)	600V	22kA	5.0 (1.52)	BWJP06021GS1	28	BWJP06025GS1	30
225	Copper	.125 (3.2)	1.0 (25)	2.5 (64)	6.13 (156)	600V	22kA	2.0 (.61)	BWJP02421GS1	10	BWJP02425GS1	12
400	Copper	.125 (3.2)	2.12 (54)	3.6 (92)	6.13 (156)	600V	35kA	10.0 (3.05)	BWJP12041GS1	69	BWJP12045GS1	79
400	Copper	.125 (3.2)	2.12 (54)	3.6 (92)	6.13 (156)	600V	35kA	5.0 (1.52)	BWJP06041GS1	35	BWJP06045GS1	40
400	Copper	.125 (3.2)	2.12 (54)	3.6 (92)	6.13 (156)	600V	35kA	2.0 (.61)	BWJP02441GS1	15	BWJP02445GS1	17

① Model Numbers Effective Aug 2011

### Feeder Section

Ampere Rating	Bus Bar Material	Bar Thickness	Bar Width	Housing Width	Housing Height	Max Voltage	Short Circuit Rating	Length In. (mm)	3 Pole		4 Pole	
									10' Model Number <sup>①</sup>	Wgt. (lb/ft)	10' Model Number <sup>①</sup>	Wgt. (lb/ft)
100	Copper	.125 (3.2)	.5 (13)	2.0 (51)	6.13 (156)	600V	10kA	16.0-120.0 (406 - 3048)	BWJF12011GS1	4.2	BWJP12015GS1	4.5
225	Copper	.125 (3.2)	1.0 (26)	2.5 (64)	6.13 (156)	600V	22kA		BWJF12021GS1	5.6	BWJP12025GS1	6.2
400	Copper	.125 (3.2)	2.12 (54)	3.6 (92)	6.13 (156)	600V	35kA		BWJF12041GS1	6.9	BWJP12045GS1	7.9

# XJ-L™ HD Busway System

## Elbows

### Fittings

Prefix	Type	Fitting Type				Amp	Configuration	Color
<b>BW</b>	<b>J</b>	<b>E</b>	<b>L</b>	<b>E</b>	<b>L</b>	<b>1</b>	<b>7</b>	<b>A</b>
		E = Edge L = Left F = Flat R = Right				1 = 100 2 = 225 4 = 400	1 = 3Ø 2 = 3Ø + Internal Grd 3 = 3Ø + Isolated Grd 4 = 3Ø + Internal Grd + Isolated Grd 5 = 3Ø + Neutral 6 = 3Ø + Neutral + Internal Grd 7 = 3Ø + Neutral + Isolated Grd 8 = 3Ø + Neutral + Internal Grd + Isolated Grd 9 = 3Ø + 200% Neutral 0 = 3Ø + 200% Neutral + Internal Ground	A = Graphite G = ANSI 61 X = Other

### Flat elbows

Right hand or left hand XJ-L HD Busway system 90 degree flat elbows are available. When specifying be sure to use the proper catalog number suffix to identify the required fitting.

#### Flat Elbow

Ampere Rating	Poles	Model Number Right	Model Number Left
100	3	BWJELFR11G	BWJELFL11G
100	4	BWJELFR15G	BWJELFL15G
225	3	BWJELFR21G	BWJELFL21G
225	4	BWJELFR25G	BWJELFL25G
400	3	BWJELFR41G	BWJELFL41G
400	4	BWJELFR45G	BWJELFL45G

### Edge elbows

Right hand or left hand XJ-L HD Busway system 90 degree edge elbows are available. When specifying, be sure to use the proper catalog number suffix to identify the required fitting.

#### Edge Elbow

Ampere Rating	Poles	Model Number Right	Model Number Left
100	3	BWJELER11G	BWJELEL11G
100	4	BWJELER15G	BWJELEL15G
225	3	BWJELER21G	BWJELEL21G
225	4	BWJELER25G	BWJELEL25G
400	3	BWJELER41G	BWJELEL41G
400	4	BWJELER45G	BWJELEL45G

15 BUSWAY SYSTEMS



Flat right elbow shown

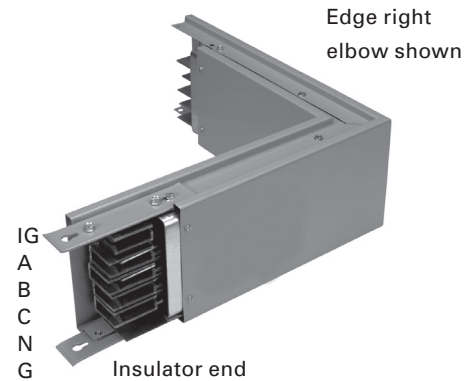

Edge right elbow shown

Left Elbow (-3)

Flat Right Elbow (-1)

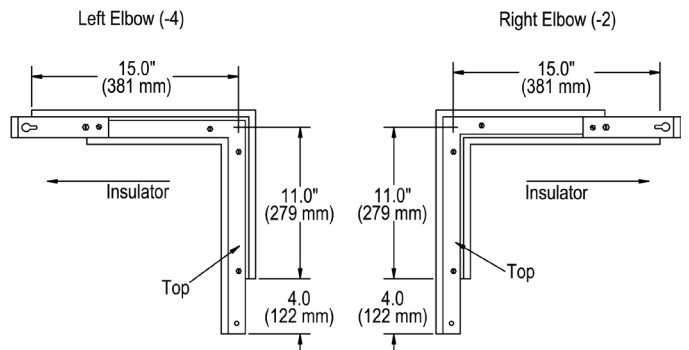
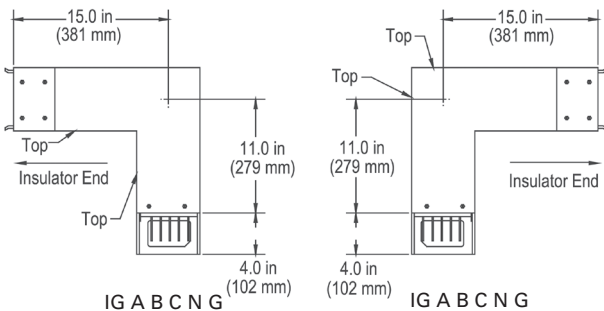

# XJ-L™ HD Busway System

## Tees and Crosses

### Fittings

Prefix	Type	Fitting Type				Amp	Configuration	Color
<b>BW</b>	<b>J</b>	<b>C</b>	<b>R</b>	<b>E</b>	<b>2</b>	<b>1</b>	<b>7</b>	<b>A</b>
XJ-L HD		<b>C</b>	<b>R</b>	<b>E = Edge</b>	<b>2</b>	<b>1 = 100 2 = 225 4 = 400</b>	<b>1 = 3Ø 2 = 3Ø + Internal Grd 3 = 3Ø + Isolated Grd 4 = 3Ø + Internal Grd + Isolated Grd 5 = 3Ø + Neutral 6 = 3Ø + Neutral + Internal Grd 7 = 3Ø + Neutral + Isolated Grd 8 = 3Ø + Neutral + Internal Grd + Isolated Grd 9 = 3Ø + 200% Neutral 0 = 3Ø + 200% Neutral + Internal Ground</b>	<b>A = Graphite G = ANSI 61 X = Other</b>

### Cross

Crosses are fittings used to interconnect two busway runs which are located at right angle to each other.

### Cross

Ampere Rating	Poles	Model Number
100	3	BWJCRE211G
100	4	BWJCRE215G
225	3	BWJCRE221G
225	4	BWJCRE225G
400	3	BWJCRE241G
400	4	BWJCRE245G

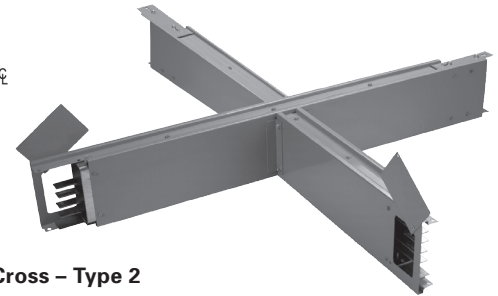
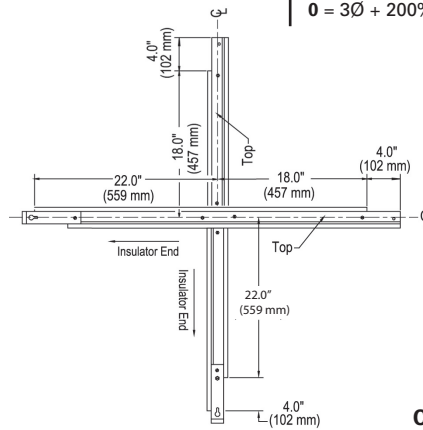

Cross - Type 2

### Fittings

Prefix	Type	Fitting Type			Amp	Configuration	Color	
<b>BW</b>	<b>J</b>	<b>T</b>	<b>E</b>	<b>E</b>	<b>2</b>	<b>1</b>	<b>A</b>	
XJ-L HD		<b>T</b>	<b>E</b>	<b>E = Edge</b>	<b>2,4</b>	<b>1 = 100 2 = 225 4 = 400</b>	<b>1 = 3Ø 2 = 3Ø + Internal Grd 3 = 3Ø + Isolated Grd 4 = 3Ø + Internal Grd + Isolated Grd 5 = 3Ø + Neutral 6 = 3Ø + Neutral + Internal Grd 7 = 3Ø + Neutral + Isolated Grd 8 = 3Ø + Neutral + Internal Grd + Isolated Grd 9 = 3Ø + 200% Neutral 0 = 3Ø + 200% Neutral + Internal Ground</b>	<b>A = Graphite G = ANSI 61 X = Other</b>

### Tee

Tees permit a second run of busway to extend at right angles to a straight busway run.

### Tees

Ampere Rating	Poles	Model Number	Model Number
100	3	BWJTEE211G	BWJTEE411G
100	4	BWJTEE215G	BWJTEE415G
225	3	BWJTEE221G	BWJTEE421G
225	4	BWJTEE225G	BWJTEE425G
400	3	BWJTEE241G	BWJTEE441G
400	4	BWJTEE245G	BWJTEE445G

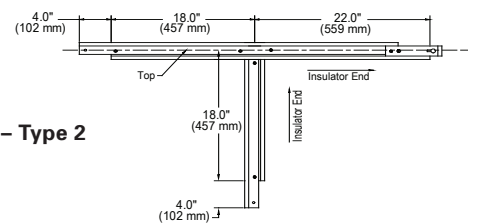

Tee - Type 2

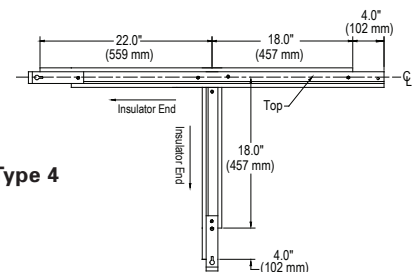

Tee - Type 4

Right Hand Shown

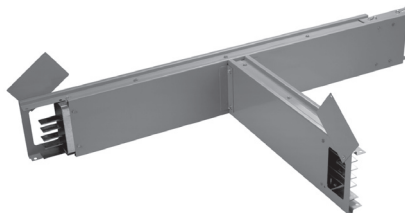

# XJ-L™ HD Busway System

## Tap Boxes

### Center Tap Boxes

Prefix	Type	Fitting Type				Amp	Config.	Color	Tap Box Only <sup>②</sup>			
BW	J	C	T	L	N	2	4	A	S	A	1	N
				L = Left (rear) R = Right (front)	N	1 = 100 2 = 225 4 = 400		A = Graphite G = ANSI 61 X = Other	S = Standard X = Custom / Other		N = None 1 = PAC3200 2 = PAC3100 X = Other	N = None / NA L = Left R = Right (Inspection Cover Side) X = Other
XJ-L HD		Center Tap Box										

Notes:  
 ① Use X for Tap Box Steel  
 ② Not required for Flanged End. Leave fields blank

1 = 3Ø  
 2 = 3Ø + Internal Grd  
 3 = 3Ø + Isolated Grd  
 4 = 3Ø + Internal Grd + Isolated Grd  
 5 = 3Ø + Neutral  
 6 = 3Ø + Neutral + Internal Grd  
 7 = 3Ø + Neutral + Isolated Grd  
 8 = 3Ø + Neutral + Internal Grd + Isolated Grd  
 9 = 3Ø + 200% Neutral  
 0 = 3Ø + 200% Neutral + Internal Ground

A = Std Mech Lug  
 B = 1.75 Dual Hole (No Lug)  
 X = Custom / Other<sup>①</sup>  
 D = Extended Box with 500MCM Mechanical

### Center Cable Tap Box

Center tap boxes are non-fusible devices utilized to feed to or take off power from the busway run. When loads served by the busway run do not require over-current protection, center tap boxes may be used. If the application requires additional wiring bending space, extended center tap boxes are available. Center tap boxes are an actual part of the busway run and require a space of 32 in. (810 mm) for installation.



Right Hand Shown

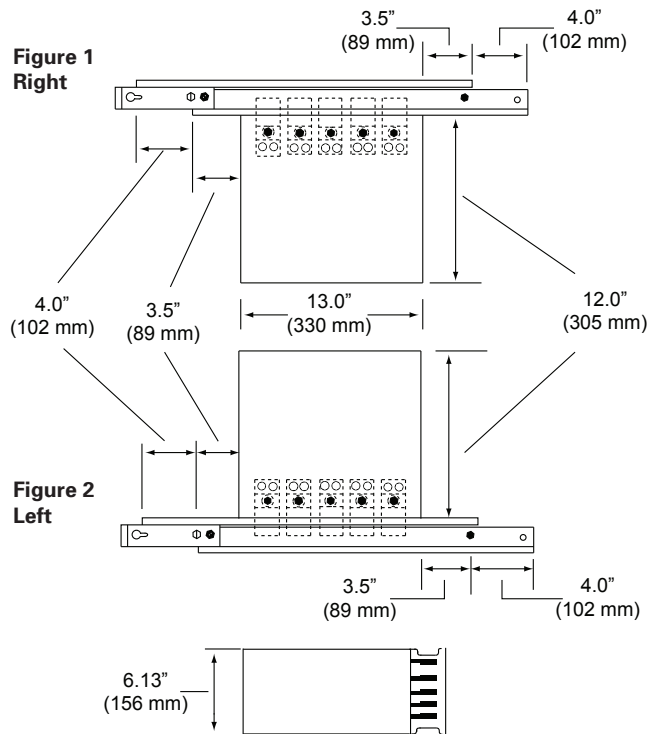

### Center Tap Box

Ampere Rating	Poles	Model Number Right Connected Fig 1	Model Number Left Connected Fig 2	Terminals Provided Qty/Pole and Size Cu/Al wire
225	3	BWJCTRN21GSANN	BWJCTLN21GSANN	(1) 350MCM - #6
225	4	BWJCTRN25GSANN	BWJCTLN25GSANN	(1) 350MCM - #6
400	3	BWJCTRN41GSANN	BWJCTLN41GSANN	(2) 350MCM - #6
400	4	BWJCTRN45GSANN	BWJCTLN45GSANN	(2) 350MCM - #6

# XJ-L™ HD Busway Systems

## Tap Boxes

### End Tap Boxes

Prefix	Type	Fitting Type				Amp	Config.	Color	Tap Box Only <sup>②</sup>			
BW	J	E	T	B	R	2	4	A	S	A	1	R
XJ-L HD	↑	E	T	B	R = Right	1 = 100 2 = 225 4 = 400		A = Graphite G = ANSI 61 X = Other	S = Standard X = Custom / Other		N = None 1 = PAC3200 2 = PAC3100 X = Other	N = None / NA L = Left R = Right (Inspection Cover Side) X = Other
<p>End Tap Box</p> <p>Notes:</p> <p>① Use X for Tap Box Steel</p> <p>② Not required for Flanged End. Leave fields blank</p> <p>1 = 3Ø 2 = 3Ø + Internal Grd 3 = 3Ø + Isolated Grd 4 = 3Ø + Internal Grd + Isolated Grd 5 = 3Ø + Neutral 6 = 3Ø + Neutral + Internal Grd 7 = 3Ø + Neutral + Isolated Grd 8 = 3Ø + Neutral + Internal Grd + Isolated Grd 9 = 3Ø + 200% Neutral 0 = 3Ø + 200% Neutral + Internal Ground</p> <p>A = Std Mech Lug B = 1.75 Dual Hole (No Lug) X = Custom / Other<sup>①</sup> D = Extended Box with 500MCM Mechanical</p>												

### End Tap Box

End tap boxes are devices used to connect cable and conduit to the end of a busway run or where busway runs connect without the need for over-current protection. End tap boxes may be installed at the end or beginning of a run.

Tap boxes can be configured with surge protection and current monitoring devices.

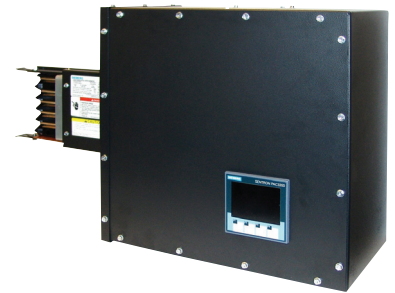

Right Hand Shown

### End Tap Box

Ampere Rating	Poles	Model Number	Terminals Provided Qty/Pole and Size Cu/Al wire
100	3	BWJETBR11GS	(1) 1/0 - #14
100	4	BWJETBR15GS	(1) 1/0 - #14
225	3	BWJETBR21GS	(1) 350MCM - #6
225	4	BWJETBR25GS	(1) 350MCM - #6
400	3	BWJETBR41GS	(2) 350MCM - #6
400	4	BWJETBR45GS	(2) 350MCM - #6

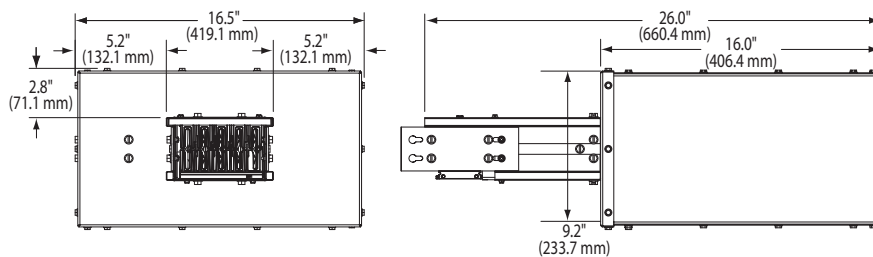



# XJ-L™ HD Busway System

## Flanged Ends

### Flanged End

Prefix	Type	Fitting Type				Amp	Config.	Color
<b>BW</b>	<b>J</b>	<b>F</b>	<b>R</b>	<b>N</b>	<b>N</b>	<b>2</b>	<b>4</b>	<b>A</b>
XJ-L HD			E = Std. R = Nema X = Other	N	N	1 = 100 2 = 225 4 = 400	1 = 3Ø 2 = 3Ø + Internal Grd 3 = 3Ø + Isolated Grd 4 = 3Ø + Internal Grd + Isolated Grd 5 = 3Ø + Neutral 6 = 3Ø + Neutral + Internal Grd 7 = 3Ø + Neutral + Isolated Grd 8 = 3Ø + Neutral + Internal Grd + Isolated Grd 9 = 3Ø + 200% Neutral 0 = 3Ø + 200% Neutral + Internal Ground	A = Graphite G = ANSI 61 X = Other
Flanged End								

### Flanged end

Flanged ends are used to connect busway to switchboards. Flanged ends come complete with bus bar extensions to facilitate the making of electrical connections.

### Flanged end

Ampere Rating	Poles	Model Number
100	3	BWJFENN11GS
100	4	BWJFENN15GS
225	3	BWJFENN21GS
225	4	BWJFENN25GS
400	3	BWJFENN41GS
400	4	BWJFENN45GS

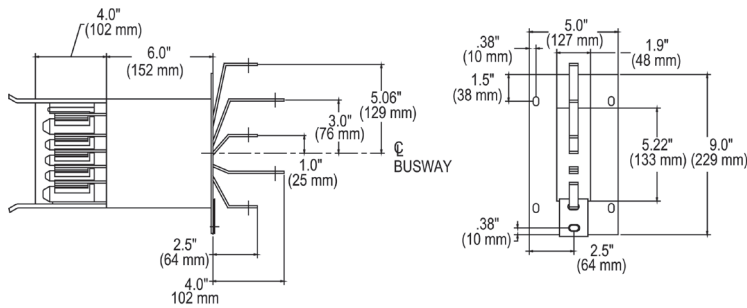
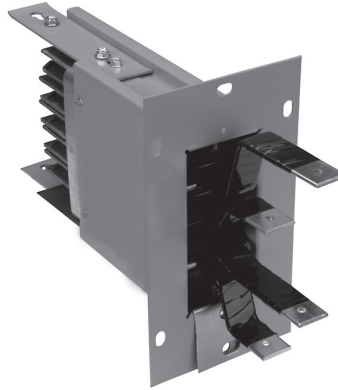

# XJ-L™ HD Busway Systems

## Accessories

### Busway hanger

XH2 and XH3 hangers are used to support XJ-L HD Busway and can be used with customer supplied rods up to 3/8 inch in diameter. Hangers are adaptable for wall mounting or ceiling suspension arrangements, either edge or flat. Custom mounting solutions available upon request.

#### Busway Hanger

Ampere Rating	Model Number	Dimn A in. (mm)
100	BWJH0011G	2.25 (57)
225	BWJH0012G	2.75 (69)
400	BWJH0014G	4 (101)

**Tip:** Bus plug access may be restricted by hangers or drop rods. This should be considered in the system layout.

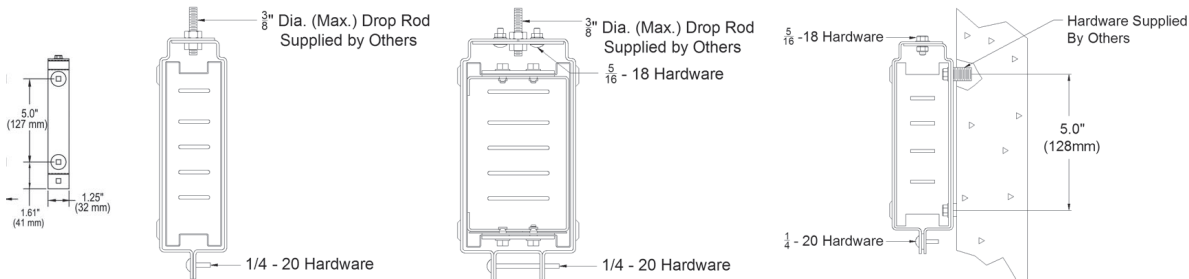

#### Hangers

Prefix	Type	Fitting Type			Amp	Color
<b>BW</b>	<b>J</b>	<b>H</b>	<b>0</b>	<b>0</b>	<b>1</b>	<b>G</b>
XJ-L HD	Hanger				1 = 100 2 = 225 4 = 400	A = Graphite G = ANSI 61 X = Other
<b>Notes:</b> ① MTO-E Custom Product 001 = Single Drop Rod (XH style) 002 = Side Mount for strut channel <sup>①</sup> 003 = Saddle Mount for strut channel <sup>①</sup> 004 = Pole Mount <sup>①</sup> 005 = Dual Drop Rod Saddle <sup>①</sup> 006 = Dual/Single Drop Rod Frame XXX = Other <sup>①</sup>						



### End closer

An end closer is used to terminate busway runs. To extend the run, simply remove the end closer and add new sections as needed.



#### End Closer

Prefix	Type	Fitting Type			Amp	Color
<b>BW</b>	<b>J</b>	<b>X</b>	<b>E</b>	<b>N</b>	<b>1</b>	<b>G</b>
XJ-L HD	End Closer	X	E	N	1 = 100 2 = 225 4 = 400	A = Graphite G = ANSI 61 X = Other

#### End Closer

Ampere Rating	Model Number	Dimn. A in (mm)	Dimn. B in (mm)
100	BWJXENN1G	2.06 (52)	0.94 (24)
225	BWJXENN2G	2.31 (59)	1.44 (37)
400	BWJXENN4G	3.44 (87)	2.5 (64)

**Tip:** Utilization of the busway plug-in opening adjacent to the End Closer may be limited to XQ45 bus plugs. This applies only if the End Closer is located to the Right-hand of the bus plug.

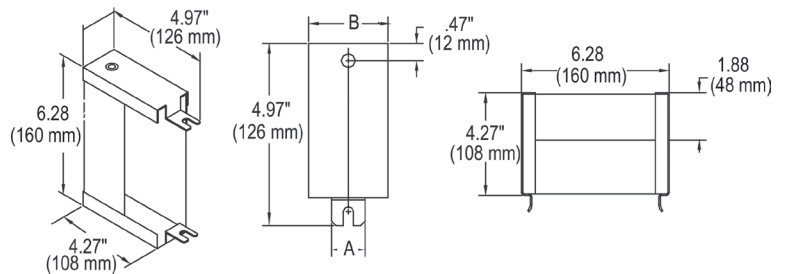

### XOC outlet covers

Replacement outlet covers are available for closing off the plug-in outlets when desired.

#### Outlet Cover

Ampere Rating	Model Number <sup>①</sup>
100	BWJXOCN1G
225	BWJXOCN2G
400	BWJXOCN4G



#### Outlet Cover

Prefix	Type	Fitting Type			Amp	Color	
<b>BW</b>	<b>J</b>	<b>X</b>	<b>O</b>	<b>C</b>	<b>N</b>	<b>G</b>	
XJ-L HD	Plug-in Cover	X	O	C	N	1 = 100 2 = 225 4 = 400	A = Graphite G = ANSI 61 X = Other

# XJ-L™ HD Busway Systems

## Bus Plugs

Bus plugs for XJ-L Busway are available from 15A to 100A, with molded case circuit breakers or Vacu-Break fusible switches. All XJ-L bus plugs are fully interchangeable with all XJ-L Busway configurations.

Lightweight and portable, plugs can be installed or relocated as required **without de-energizing the busway**. Pre-engineered plug-in opening locations ensure no interference for **greater density** and maximum flexibility. This is especially important in high tech areas requiring frequent movement of equipment.

XJ-L HD Bus Plugs are available with 3 or 6 branch circuit protection in both single and 3-phase configurations, ranging from 15A – 100A for maximum power density and flexibility.

A wide variety of NEMA and IEC receptacles or cord connections are available for the XJ-L Bus Plugs.



### Selection Guide

Enclosure Type	Plug-in Spacing	Breaker Type	Application
A = 3 Circuit - XQ Series	20.00 & 9.75	BQ, BQH, HBQ	XQ style - No receptacle
B = 3 Circuit - XQR Series	20.00 & 9.75 <sup>⑩</sup>		XQR style — with duplex receptacle provision. May be used for custom receptacles or when additional wiring space is required
C = 3 Circuit HD XPM	20.00 & 9.75	BL, BLH, HBL, BQD, NGB	Use for applications that require factory installed breakers and receptacles
D = 3-6 Circuit HD XPM	20.00 & 9.75		
G = XLEC	20.00 & 9.75 <sup>⑩</sup>	ED2,ED4,ED6, HED4	Cover operable handle. Uses heavy duty E-Frame Breakers
H = XEC	20.00 & 9.75 <sup>⑩</sup>		Uses heavy duty E-Frame breakers
J = Plug-in Tap Box	20.00	na	Plug-in tap off device - lugs only
K = XLVB Fusible	20.00 & 9.75 <sup>⑩</sup>	na	Cover operable Vacu-Break Switch

### Siemens XJ-L™ HD Bus Plugs and Power Modules

Use For Breaker Group = A, B, X<sup>④</sup>

Prefix	Type	Enclosure	System Config.	Color	Breaker Group	Ampere Rating or Breaker/Receptacle Arrangement <sup>⑤⑥⑦⑧</sup>	Custom Features
<b>BP</b>	<b>J</b>	<b>H</b>	<b>6</b>	<b>A</b>	<b>A</b>	<b>E D 4 6 0</b>	<b>N N</b>
Bus Plug XJ-L HD		A = 3 Circuit XQ Series B = 3 Circuit – XQ Series Receptacle Provision C = 3 Circuit HD XPM D = 3-6 Circuit HD XPM G = XLEC <sup>②③⑩⑪</sup> H = XEC <sup>③⑥⑩</sup> J = Plug-in Tap Box <sup>②④⑧⑪</sup> K = XLVB Fusible <sup>②④⑦⑩</sup>	1 = 3Ø 2 = 3Ø + Internal Grd 3 = 3Ø + Isolated Grd 4 = 3Ø + Internal Grd + Isolated Grd 5 = 3Ø + Neutral 6 = 3Ø + Neutral + Internal Grd 7 = 3Ø + Neutral + Isolated Grd 8 = 3Ø + Neutral + Internal Grd + Isolated Grd 9 = 3Ø + 200% Neutral 0 = 3Ø + 200% Neutral + Internal Ground	A = Graphite G = ANSI 61 X = Other	A = Non-Mixed Factory Installed Breakers <sup>①</sup> E = Enclosure Only (no Breaker) <sup>①②</sup> X = Other / Fusible <sup>②</sup>	See Notes below for information	NN = None / NA

#### Notes:

- ① Use "A" or "E" for XLEC and XEC
- ② Available in System Configs: 1,2,5,6
- ③ Available in System Configs: 1,2,3,4,5,6,7,8,9
- ④ For non-breaker style plug use "X" for Breaker Grouping field. (Fusible & Plug-in Tap Box)
- ⑤ For Enclosure = C,E,F see Breaker / Receptacle Arrangement Schedule for Details
- ⑥ For XEC and XLEC Ampere Rating field use ED2xx, ED4xx,ED6xx where xx = 15 to 00 trip rating (100A max).
- ⑦ For XLVB Ampere Rating field use 02xxx for 240V & 06xxx for 600V where xxx = 030, 060, 100 ampere
- ⑧ For Plug-in Tap Box Ampere Rating field use PBxxx where xxx = 100, 200 ampere
- ⑨ Ampere Rating and Customer Features fields not required for Breaker Group = "E". Leave fields blank.
- ⑩ Requires two plug-in openings for 9.75 spacing.
- ⑪ 200A Tap Box installs on 20.0 dual side plug-in spacing only. Requires two plug-in openings.

# XJ-L™ HD Busway Systems

## Bus Plugs

### XQ and XQR Series

XQ and XQR bus plugs accept BQ (bolt-on) circuit breakers. The plugs feature knockouts to facilitate quick installation. The XQR has added wiring space to allow receptacle installation.

#### XQ Series Bus plug (60A max)

Breaker Type	Volts	No. of Spaces	Model Number	Model Number
BQ, BQH and HBQ	120/240	3	BPJA1GE	BPJA5GE

Enclosure Only

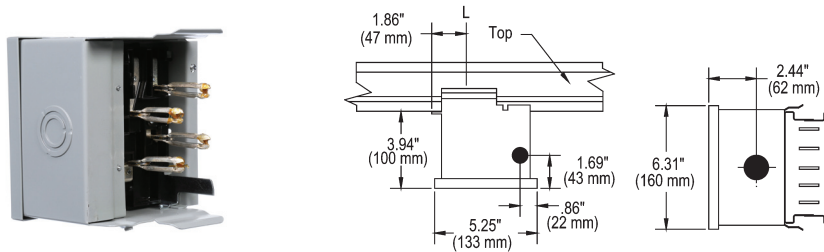

#### XQR Series Bus plug (60A max)

Breaker Type	Volts	No. of Spaces	Model Number	Model Number
BQ, BQH and HBQ	120/240	3	BPJB1GE	BPJB5GE

Enclosure Only

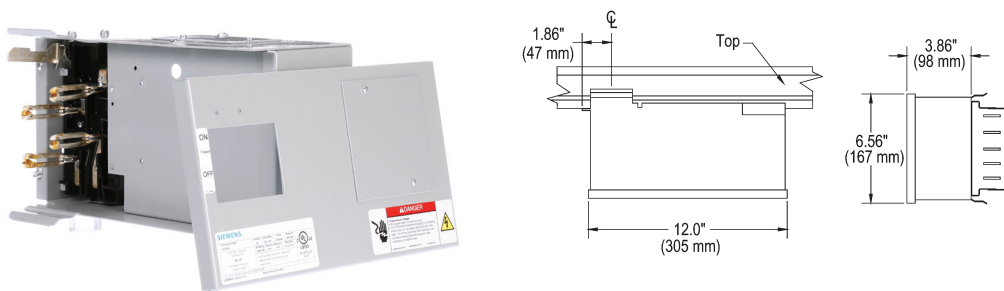

#### Accessories for XQ and XQR Series

<b>XEQH</b>	Floor Operating Handle (not for 1 pole or 2 pole breakers)
<b>W62890</b>	Bonded Ground Kit
<b>W68101</b>	Isolated Ground Kit

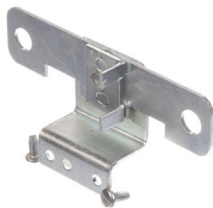

XEQH

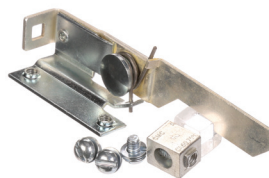

W62890

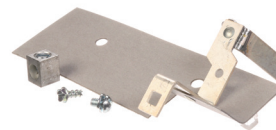

W68101

# XJ-L™ HD Busway Systems

## Bus Plugs

### XPM Series

Use for applications that require factory installed breakers and receptacles.

#### XPM Series HD Bus plug 3/6

Breaker Type	Interrupt Rating (RMS kA)	Config.	No. of Spaces	Model Number
BL	10	1-pole 120V	6	BPJE...
BLH	10	1-pole 120V		
	22	1-pole 120V		
	22	3-pole 240V		
	10	2-pole 120/240V		
	10	3-pole 120/240V		
	22	2-pole 120/240V		
HBL	22	3-pole 120/240V		
	10	1-pole 120V		
	22	1-pole 120V		
	65	1-pole 120V		
	22	3-pole 240V		
	65	3-pole 240V		
	10	2-pole 120/240V		
	10	3-pole 120/240V		
	22	2-pole 120/240V		
	22	3-pole 120/240V		
BQD	65	1-pole 120V		
	10	1-pole 120V		
	10	2-pole 240V		
	10	3-pole 240V		
	22	2-pole 240V		
	22	3-pole 240V		
	65	2-pole 240V		
	65	3-pole 240V		
	10	2-pole 120/240V		
	10	3-pole 120/240V		
	22	2-pole 120/240V		
	22	3-pole 120/240V		
	65	2-pole 120/240V		
	65	3-pole 120/240V		
NGB	14	1-pole 227V		
	14	2-pole 227/480V		
	14	3-pole 227/480V		
	10	1-pole 120V		
	22	1-pole 120V		
	65	1-pole 120V		
	10	2-pole 240V		
	10	3-pole 240V		
	22	2-pole 240V		
	22	3-pole 240V		
	65	2-pole 240V		
	65	3-pole 240V		
	10	2-pole 120/240V		
	10	3-pole 120/240V		
22	2-pole 120/240V			
22	3-pole 120/240V			
65	2-pole 120/240V			
65	3-pole 120/240V			
14	1-pole 227V			
25	1-pole 227V			
14	2-pole 227/480V			
14	3-pole 227/480V			
25	2-pole 227/480V			
25	3-pole 227/480V			
14	1-pole 347V			
14	2-pole 347/600V			
14	3-pole 347/600V			

#### XPM Series HD Bus plug 3 Circuit

Breaker Type	Interrupt Rating (RMS kA)	Config.	No. of Spaces	Model Number
BQ	10	1-pole 120V	3	BPJC...
	10	2-pole 240 V		
	10	3-pole 240 V		
	10	2-pole 120/240 V		
	10	3-pole 120/240 V		
	10	1-pole 120V		
BQH	22	1-pole 120V		
	22	3-pole 240 V		
	10	2-pole 120/240 V		
	10	3-pole 120/240 V		
	22	2-pole 120/240 V		
	22	3-pole 120/240 V		
HBQ	10	1-pole 120V		
	22	1-pole 120V		
	65	1-pole 120V		
	22	3-pole 240 V		
	65	3-pole 240 V		
	10	2-pole 120/240 V		
	10	3-pole 120/240 V		
	22	2-pole 120/240 V		
	22	3-pole 120/240 V		
	65	2-pole 120/240 V		
65	3-pole 120/240 V			

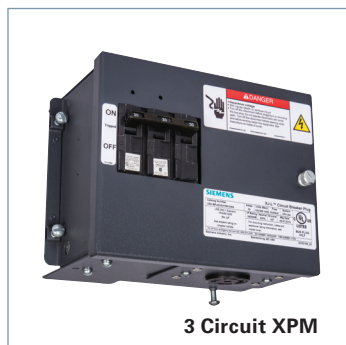
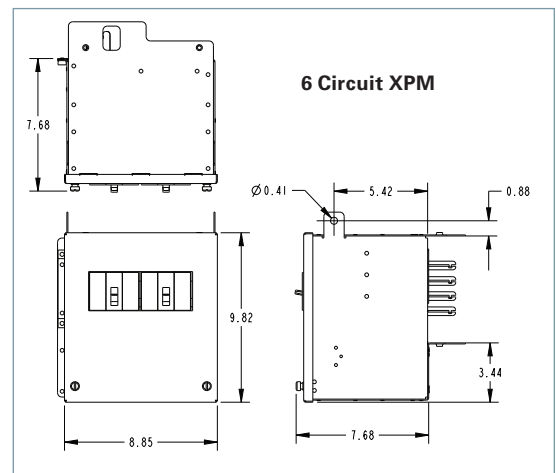
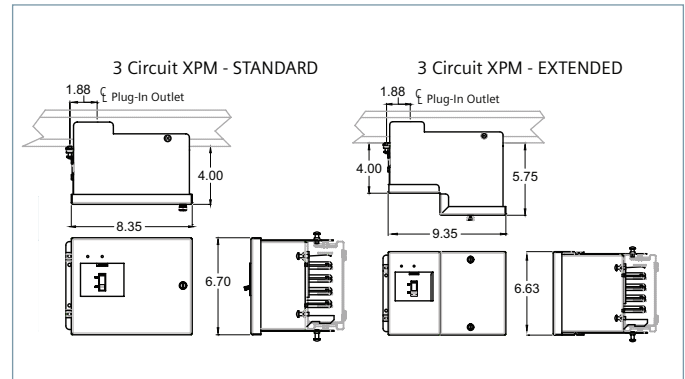

# XJ-L™ HD Busway Systems

## Bus Plugs

### XEC Series

(Cover operable, 100A max)

XEC bus plugs accept ED2, ED4, ED6 and HED6 circuit breakers. The plugs feature a spacious chassis which allows room for wire bending and knockout provisions. Isolated ground plugs are available from the factory.

#### XEC Series bus plug

Breaker Type	Volts	Ampere Rating	Model Number	Model Number
ED2	240	100	BPJH1GAED200NN	BPJH5GAED200NN
ED4	480	30	BPJH1GAED430NN	BPJH5GAED430NN
ED6	600	60	BPJH1GAED660NN	BPJH5GAED660NN
Enclosure Only	600 Max	15-100	BPJH1GE	BPJH5GE

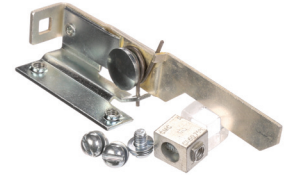

**W62890**  
bonded  
ground kit

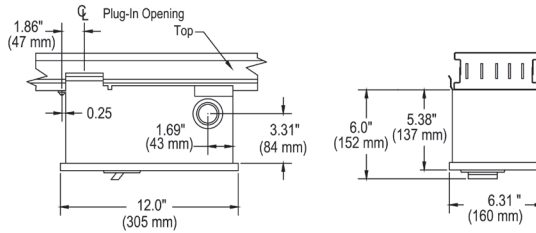

### XLEC Series

(Floor operable, 100A max)

XLEC bus plugs accept ED2, ED4, ED6 and HED4 circuit breakers. The plugs feature a spacious chassis which allows room for wire bending and knockout provisions. These plugs may be operated from the floor with a pull chain or hookstick.

#### XLEC Series bus plug

Breaker Type	Volts	Ampere Rating	Model Number	Model Number
ED2	240	100	BPJG1GAED200NN	BPJG5GAED200NN
ED4	480	30	BPJG1GAED430NN	BPJG5GAED430NN
ED6	600	60	BPJG1GAED660NN	BPJG5GAED660NN
Enclosure Only	600 Max	15-100	BPJG1GE	BPJG5GE

Additional add-on features, such as shunt trips, alarm switches, and auxillary contacts are also available for XEC and XLEC bus plugs.

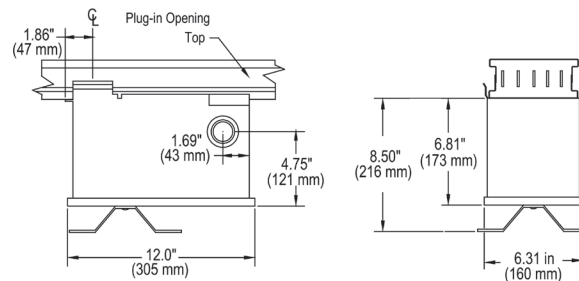
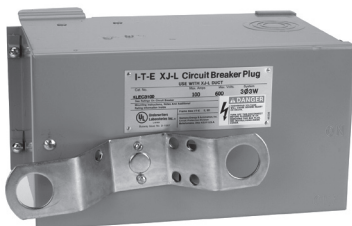



# XJ-L™ HD Busway Systems

## Bus Plugs

### XLVB Series

(Floor operable, 100A max)  
 XLVB fusible bus plugs utilize the Vacu-Break switching principle, which minimizes arcing and reduces maintenance costs. The Vacu-Break bus plugs are quick-make and quick-break, cover interlocked, horsepower rated, and may be operated from the floor with a pull chain or hookstick.



#### XLVB Series bus plug

Volts	Ampere Rating	Model Number	Model Number
240	30	BPJK1GX02030NN	BPJK5GX02030NN
240	60	BPJK1GX02060NN	BPJK5GX02060NN
240	100	BPJK1GX02100NN	BPJK5GX02100NN
600	30	BPJK1GX06030NN	BPJK5GX06030NN
600	60	BPJK1GX06060NN	BPJK5GX06060NN
600	100	BPJK1GX06100NN	BPJK5GX06100NN

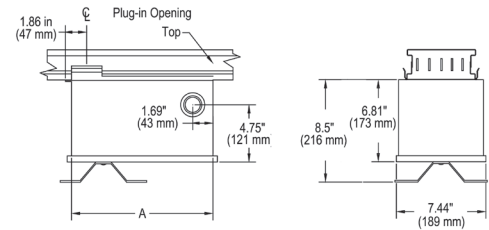

W47185  
 ON/OFF labels



### 100A Plug-in Tap Box

Plug-in cable tap boxes are non-fusible devices used for end or center feed. The 100A tap boxes can be attached at any plug-in opening.

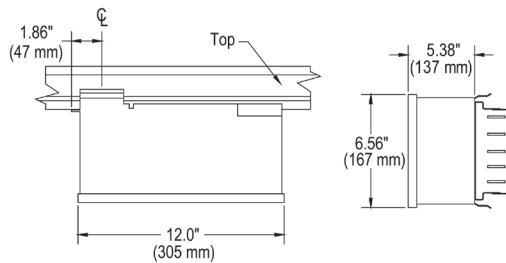

#### 100A Plug-in Tap Box

Ampere Rating	Poles	Model Number
100	3	BWJJ1GXPB100NN
100	4	BWJJ5GXPB100NN

**Note:** Add suffix letter "G" to catalog number for ground bus.

### 200A Plug-in Tap Box

Plug-in cable tap boxes are non-fusible devices used for end or center feed. The 200A tap box requires two adjacent openings on 20" centers. 200A plug-in tap boxes are not suitable for use with XJ-L HD Busway.

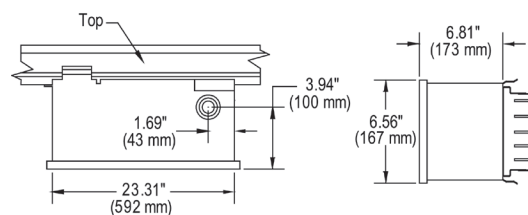

#### 200A Plug-in Tap Box

Ampere Rating	Poles	Model Number
200	3	BWJJ1GXPB200NN
200	4	BWJJ5GXPB200NN

**Note:** Add suffix letter "G" to catalog number for ground bus.

W62892  
 Grd Finger Kit

# Busway Power Distribution

BD Plug-In (225 — 1600 Ampere) Copper

Selection

Ampere Rating	Plug In 10'-0" Straight Length Catalog Number	Case Dimensions (inches)	Shipping Weight Lb./Ft.	90° Elbow Prefix ③④	Switch-Board Connection <sup>⑤</sup> Prefix	Building Expansion Fitting Catalog Number	Cable Tap Box		End Closure Catalog Number	Hangers <sup>⑥</sup> Catalog Number
							End <sup>⑦</sup> Catalog Number	Center <sup>⑦</sup> Catalog Number		
<b>3-Phase, 3-Wire</b>										
<b>600V or Less</b>										
225	BDP302	4 <sup>1</sup> / <sub>16</sub> x 8 <sup>7</sup> / <sub>8</sub>	9	LDP302	FEP302	EJP302	ETB302	CTB302	ECP6	BDH10
400	BDP304	4 <sup>1</sup> / <sub>16</sub> x 8 <sup>7</sup> / <sub>8</sub>	12 <sup>1</sup> / <sub>2</sub>	LDP304	FEP304	EJP304	ETB304	CTB304	ECP6	
600	BDP306	4 <sup>1</sup> / <sub>16</sub> x 8 <sup>7</sup> / <sub>8</sub>	13 <sup>1</sup> / <sub>2</sub>	LDP306	FEP306	EJP306	ETB306	CTB306	ECP6	
800	BDP308	6 <sup>1</sup> / <sub>16</sub> x 8 <sup>7</sup> / <sub>8</sub>	18 <sup>1</sup> / <sub>2</sub>	LDP308	FEP308	EJP308	ETB308	CTB308	ECP10	
1000	BDP310	6 <sup>1</sup> / <sub>16</sub> x 8 <sup>7</sup> / <sub>8</sub>	22	LDP310	FEP310	EJP310	ETB310	CTB310	ECP10	BDH12
1350	BDP313	12 <sup>1</sup> / <sub>16</sub> x 8 <sup>7</sup> / <sub>8</sub>	28	LDP313	FEP313	EJP313	ETB313	CTB313	ECA10	
1600	BDP316	12 <sup>1</sup> / <sub>16</sub> x 8 <sup>7</sup> / <sub>8</sub>	29	LDP316	FEP316	EJP316	ETB316	CTB316	ECA10	
<b>3-Phase, 4-Wire — Full Capacity Neutral</b>										
<b>480V or Less</b>										
225	BDP4024	4 <sup>1</sup> / <sub>16</sub> x 8 <sup>7</sup> / <sub>8</sub>	12	LDP4024	FEP4024	EJP4024	ETB4024	CTB4024	ECP6	BDH10
400	BDP4044	4 <sup>1</sup> / <sub>16</sub> x 8 <sup>7</sup> / <sub>8</sub>	14 <sup>1</sup> / <sub>2</sub>	LDP4044	FEP4044	EJP4044	ETB4044	CTB4044	ECP6	
600	BDP4064	4 <sup>1</sup> / <sub>16</sub> x 8 <sup>7</sup> / <sub>8</sub>	15 <sup>1</sup> / <sub>2</sub>	LDP4064	FEP4064	EJP4064	ETB4064	CTB4064	ECP6	
800	BDP4084	8 <sup>7</sup> / <sub>16</sub> x 8 <sup>7</sup> / <sub>8</sub>	28	LDP4084	FEP4084	EJP4084	ETB4084	CTB4084	ECA8	BDH12
1000	BDP4104	8 <sup>7</sup> / <sub>16</sub> x 8 <sup>7</sup> / <sub>8</sub>	32	LDP4104	FEP4104	EJP4104	ETB4104	CTB4104	ECA8	
Rod-Hanger Adapter (optional)			UJ100							

## Aluminum to Copper Cross Reference

Aluminum BD Busway is no longer available. Please use the cross reference below to identify compatible copper equivalent.

Ampere Rating	Plug In 10'-0" Straight Length Catalog Number	Case Dimensions (inches)	Ampere Rating	Plug In 10'-0" Straight Length Catalog Number	Case Dimensions (inches)
---------------	---	--------------------------	---------------	---	--------------------------

### Aluminum

#### 3-Phase, 3-Wire

225	ABD302	4 <sup>1</sup> / <sub>16</sub> x 8 <sup>7</sup> / <sub>8</sub>
400	ABD304	4 <sup>1</sup> / <sub>16</sub> x 8 <sup>7</sup> / <sub>8</sub>
600	ABD306	6 <sup>1</sup> / <sub>16</sub> x 8 <sup>7</sup> / <sub>8</sub>
800	ABD308	6 <sup>1</sup> / <sub>16</sub> x 8 <sup>7</sup> / <sub>8</sub>
1000	ABD310	12 <sup>1</sup> / <sub>16</sub> x 8 <sup>7</sup> / <sub>8</sub>
1200	ABD312	12 <sup>1</sup> / <sub>16</sub> x 8 <sup>7</sup> / <sub>8</sub>

#### 3-Phase, 4-Wire — Full Capacity Neutral

225	ABD4024	4 <sup>1</sup> / <sub>16</sub> x 8 <sup>7</sup> / <sub>8</sub>
400	ABD4044	4 <sup>1</sup> / <sub>16</sub> x 8 <sup>7</sup> / <sub>8</sub>
600	ABD4064	6 <sup>1</sup> / <sub>16</sub> x 8 <sup>7</sup> / <sub>8</sub>
800	ABD4084	8 <sup>7</sup> / <sub>16</sub> x 8 <sup>7</sup> / <sub>8</sub>
1000	ABD4104	12 <sup>1</sup> / <sub>16</sub> x 8 <sup>7</sup> / <sub>8</sub>
1200	ABD4124	12 <sup>1</sup> / <sub>16</sub> x 8 <sup>7</sup> / <sub>8</sub>

### Copper

#### 3-Phase, 3-Wire

225	BDP302	4 <sup>1</sup> / <sub>16</sub> x 8 <sup>7</sup> / <sub>8</sub>
400	BDP304	4 <sup>1</sup> / <sub>16</sub> x 8 <sup>7</sup> / <sub>8</sub>
600	BDP306	4 <sup>1</sup> / <sub>16</sub> x 8 <sup>7</sup> / <sub>8</sub>
800	BDP308	6 <sup>1</sup> / <sub>16</sub> x 8 <sup>7</sup> / <sub>8</sub>
1000	BDP310	6 <sup>1</sup> / <sub>16</sub> x 8 <sup>7</sup> / <sub>8</sub>
1350	BDP313	12 <sup>1</sup> / <sub>16</sub> x 8 <sup>7</sup> / <sub>8</sub>
1600	BDP316	12 <sup>1</sup> / <sub>16</sub> x 8 <sup>7</sup> / <sub>8</sub>

#### 3-Phase, 4-Wire — Full Capacity Neutral

225	BDP4024	4 <sup>1</sup> / <sub>16</sub> x 8 <sup>7</sup> / <sub>8</sub>
400	BDP4044	4 <sup>1</sup> / <sub>16</sub> x 8 <sup>7</sup> / <sub>8</sub>
600	BDP4064	4 <sup>1</sup> / <sub>16</sub> x 8 <sup>7</sup> / <sub>8</sub>
800	BDP4084	8 <sup>7</sup> / <sub>16</sub> x 8 <sup>7</sup> / <sub>8</sub>
1000	BDP4104	8 <sup>7</sup> / <sub>16</sub> x 8 <sup>7</sup> / <sub>8</sub>

## "M" Rating / Standard Rating Conversion Table

1000/A Square Inch "M" Rating	Standard Rating Equivalent
225	—
400	600
600	800
800	800
1000	1000
1200	—
1350	1350
1600	1600
2000	—
2500	—
3000	—
4000	—

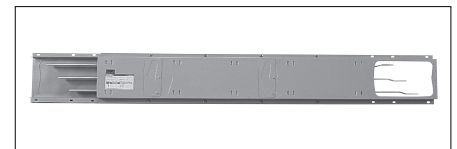

Suffix	Description	Appropriate suffix must be added to Elbow Catalog Number to order.
-1	Right Flatwise	
-2	Right Edgewise	
-3	Left Flatwise	
-4	Left Edgewise	

For inches / millimeters conversion, see Application Data Section.

① For higher short circuit ratings add an "H" after the "D" or "P" (ABDH302 or BDPH302). Consult sales office for ratings.

② "GK" suffix is an internal ground bus. For any other ground configuration, consult local sales office. Please use following footage for fittings:

- Elbow - 3'
- SWB - 1'
- End Cable Tap Box - 1'
- Center Cable Tap Box - 10'
- Building Expansion - 10'

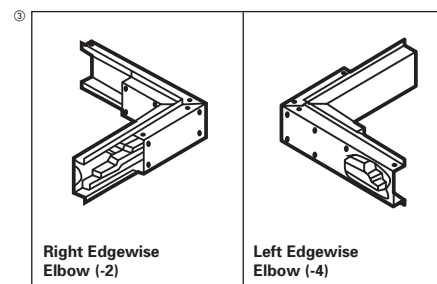

③ Switchboard stub includes flange to cover cutout in top of indoor switchboard and 6" of bus inside switchboard. Connecting hardware supplied by switchboard manufacturer.

④ Includes busway stub. Total length added to run is 2' for 225A and 400A aluminum or 225A-600A copper; 3' for all others. Box is designed to connect to offset bus-bar ends. When it is to be connected to straight bus-bar ends, adapter will be furnished upon request.

⑤ Must be factory-assembled to busway. Complete device includes 10' busway.

⑥ Two hangers included free of charge with each busway section, elbow, tee and cross.

# Busway Power Distribution

XL-U Aluminum (225–5000 Ampere)

Selection

## 225–5000 Amperes / 600 Volts or Less Non-Ventilated 225–600 Amperes

Busway Catalog Number				Wall Flange Catalog Number	Floor Support Catalog Number	End Closure Catalog Number	Hangers® Catalog Number
Ampere Rating	Basic Catalog Number	Case Dimensions (inches)	Shipping Weight Lb./Ft.				

### 3-Pole

225	UH302AB	4½ x 10	8	UF145	UFS145	UE145	UH145
400	UH304AB	4½ x 10	9	UF145	UFS145	UE145	UH145
600	UH306AB	5½ x 10	10	UF145	UFS145	UE155	UH155

### 4-Pole Full Neutral

225	UH502AB	4½ x 10	8	UF145	UFS145	UE145	UH145
400	UH504AB	4½ x 10	9	UF145	UFS145	UE145	UH145
600	UH506AB	5½ x 10	10	UF145	UFS145	UE155	UH155

## Ventilated 800–5000 Amperes With Ground Bus

Busway Sections Complete					Wall Flange Catalog Number	Floor Support Catalog Number	End Closure Catalog Number	Hangers® Catalog Number
Ampere Rating①		Basic Catalog Number	Case Dimensions (inches)	Shipping Weight Lb./Ft.				
Edge-wise 	Flat-wise — — —							

### 3-Pole

800	800	UH308AV	4½ x 10	10	UF145	UFS145	UE145	UH145
1000	800	UH310AV	4½ x 10	11	UF145	UFS145	UE145	UH145
1200	1000	UH312AV	5½ x 10	12	UF155	UFS145	UE155	UH155
1350	1200	UH313AV	5½ x 10	13	UF155	UFS145	UE155	UH155
1600	1350	UH316AV	7½ x 10	16	UF175	UFS179	UE175	UH175
2000	1600	UH320AV	7½ x 10	19	UF175	UFS179	UE175	UH175
2500	2000	UH325AV	9½ x 10	23	UF195	UFS179	UE175	UH195
3000	3000	UH330AV	7½ x 20%	32	UF275	UFS279	UE275	UH275
4000	3500	UH340AV	9½ x 20%	41	UF295	UFS279	UE295	UH295
5000	4000	UH350AV	9½ x 20%	45	UF295	UFS279	UE295	UH295

### 4-Pole Full Neutral

800	800	UH508AV	4½ x 10	11	UF145	UFS145	UE145	UH145
1000	800	UH510AV	4½ x 10	12	UF145	UFS145	UE145	UH145
1200	1000	UH512AV	5½ x 10	14	UF155	UFS145	UE155	UH155
1350	1200	UH513AV	5½ x 10	15	UF155	UFS145	UE155	UH155
1600	1350	UH516AV	7½ x 10	18	UF175	UFS179	UE175	UH175
2000	1600	UH520AV	7½ x 10	21	UF175	UFS179	UE175	UH175
2500	2000	UH525AV	9½ x 10	26	UF195	UFS179	UE195	UH195
3000	3000	UH530AV	7½ x 20%	35	UF275	UFS279	UE275	UH275
4000	3500	UH540AV	9½ x 20%	47	UF295	UFS279	UE295	UH295
5000	4000	UH550AV	9½ x 20%	52	UF295	UFS279	UE295	UH295

① Ventilated XL-U busway has two ratings; see above for edgewise or flatwise mounting.

② For rod-hanger adapter UJ100 see page 15-80.

#### GENERAL NOTES:

- For inches / millimeters conversion, see Application Data Section.
- To form complete catalog number, use basic catalog number and substitute suffix of required item. Example: Basic busway Catalog Number U316AV— accessory switchboard stub with ground bus U316AVSG.
- Totally Enclosed offering is available up to 3000A Al. Replace "V" with "E" in catalog number.
- The following feeder busway footages apply:  
XL-U Elbow 2' XL-U EXP Section 4'  
XL-U Tee 3' XL-U SWBD Stub 1'  
XL-U Cross 4' XL-U Reducer 4'

- For higher short circuit rating add an "HH" after the "U" (UHH302ABP)
- Floor and ceiling flanges are ordered by description.
- Internal ground bar provided as standard.
- For elbows other than 90°, accessory charge is doubled.
- Switchboard stub includes flange to cover cutout in top of indoor switchboard and 8" of bus inside switchboard. Connecting hardware supplied by switchboard manufacturer.
- Transformer throat connection includes gasketed box sized to match throat plus flexible straps and bolts. No Busway footage is included. For connection to transformers not manufactured by Siemens, consult factory

### XLU Suffix Table

Description	Suffix
Feeder	F
Plug-in	P
Elbow	L
Tee	T
Cross	X
Switchboard Connection	S
Expansion Section	J
Center Tap Box	M
End Tap Box	B
XFMR Throat	—
XFMR Tap 1-3 Phase	—
XFMR Tap 3-1 Phase	—
Roof Flange	—
Fused Reducer	—
Non Fused Reducer	—

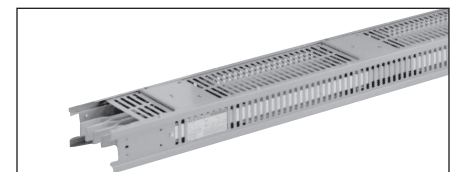

# Busway Power Distribution

XL-U Copper (225–6500 Amperes)

Selection

## 225–6500 Amperes / 600 Volts or Less Non-Ventilated 225–600 Amperes

Busway Catalog Number				Wall Flange Catalog Number	Floor Support Catalog Number	End Closure Catalog Number	Hangers <sup>®</sup> Catalog Number
Ampere Rating	Basic Catalog Number	Case Dimensions (inches)	Shipping Weight Lb./Ft.				

### 3-Pole

225	UH302CB	4½ x 10	8	UF145	UFS145	UE145	UH145
400	UH304CB		12	UF145	UFS145	UE145	UH145
600	UH306CB		13	UF145	UFS145	UE145	UH145

### 4-Pole Full Neutral

225	UH502CB	4½ x 10	9	UF145	UFS145	UE145	UH145
400	UH504CB		13	UF145	UFS145	UE145	UH145
600	UH506CB		15	UF145	UFS145	UE145	UH145

## Ventilated 800–5000 Amperes With Ground Bus

Busway Sections Complete					Wall Flange Catalog Number	Floor Support Catalog Number	End Closure Catalog Number	Hangers <sup>®</sup> Catalog Number
Ampere Rating <sup>①</sup>		Basic Catalog Number	Case Dimensions (inches)	Shipping Weight Lb./Ft.				
Edge-wise	Flat-wise							

### 3-Pole

	800	UH308CV	4½ x 10	12	UF145	UFS145	UE145	UH145
1000	1000	UH310CV	4½ x 10	15	UF145	UFS145	UE145	UH145
1200	1000	UH312CV	4½ x 10	16	UF145	UFS145	UE145	UH145
1350	1200	UH313CV	4½ x 10	19	UF145	UFS145	UE145	UH145
1600	1350	UH316CV	5½ x 10	23	UF155	UFS145	UE155	UH155
2000	1600	UH320CV	5½ x 10	26	UF155	UFS145	UE155	UH155
2500	2000	UH325CV	7½ x 10	34	UF175	UFS179	UE175	UH175
3000	2500	UH330CV	9½ x 10	41	UF195	UFS179	UE195	UH195
4000	4000	UH340CV	7½ x 20%	57	UF275	UFS279	UE275	UH275
5000	4500	UH350CV	7½ x 20%	70	UF275	UFS275	UE275	UH275
6000	5000	UH360CV	9½ x 20%	85	UF295	UFS279	UE295	UH295
6500	5500	UH365CV	9½ x 20%	98	UF295	UFS279	UE295	UH295

### 4-Pole Full Neutral

800	800	UH508CV	4½ x 10	14	UF145	UFS145	UE145	UH145
1000	1000	UH510CV	4½ x 10	18	UF145	UFS145	UE145	UH145
1200	1000	UH512CV	4½ x 10	19	UF145	UFS145	UE145	UH145
1350	1200	UH513CV	4½ x 10	23	UF145	UFS145	UE145	UH145
1600	1350	UH516CV	5½ x 10	28	UF155	UFS145	UE155	UH155
2000	1600	UH520CV	5½ x 10	30	UF155	UFS145	UE155	UH155
2500	2000	UH525CV	7½ x 10	42	UF175	UFS179	UE175	UH175
3000	2500	UH530CV	7½ x 10	61	UF195	UFS179	UE195	UH195
4000	4000	UH540CV	7½ x 20%	70	UF275	UFS279	UE275	UH275
5000	4500	UH550CV	7½ x 20%	86	UF275	UFS279	UE275	UH275
6000	5000	UH560CV	9½ x 20%	105	UF295	UFS279	UE295	UH295
6500	5500	UH565CV	9½ x 20%	122	UF295	UFS279	UE295	UH295

### "M" Rating / Standard Rating Conversion Table

1000/A Square Inch "M" Rating	Standard Rating Equivalent
225	—
400	—
600	800
800	1200
1000	1350
1200	1600
1350	2000
1600	2500
2000	2500
2500	3000
3000	4000
4000	5000

① Ventilated XL-U busway has two ratings; see above for edgewise or flatwise mounting.

② For rod-hanger adapter UJ100 see page 15-80.

#### GENERAL NOTES:

- For inches / millimeters conversion, see Application Data Section.
- To form complete catalog number, use basic catalog number and substitute suffix of required item. Example: Basic busway Catalog Number U316CV— accessory switchboard stub with ground bus U316CVSG.
- Totally Enclosed offering is available up to 4000A Cu. Replace "V" with "E" in catalog number.
- The following feeder busway footages apply:  
XL-U Elbow 2' XL-U EXP Section 4'  
XL-U Tee 3' XL-U SWBD Stub 1'  
XL-U Cross 4' XL-U Reducer 4'
- For higher short circuit rating add an "HH" after the "U" (UHH302CBP)
- Floor and ceiling flanges are ordered by description.
- Internal ground bar provided as standard.

### XLU Suffix Table

Description	Suffix
Feeder	F
Plug-in	P
Elbow	L
Tee	T
Cross	X
Switchboard Connection	S
Expansion Section	J
Center Tap Box	M
End Tap Box	B
XFMR Throat	—
XFMR Tap 1-3 Phase	—
XFMR Tap 3-1 Phase	—
Roof Flange	—
Fused Reducer	—
Non Fused Reducer	—

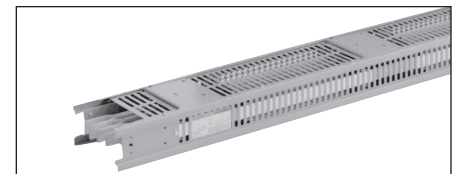

- For elbows other than 90°, accessory charge is doubled.
- Switchboard stub includes flange to cover cutout in top of indoor switchboard and 8" of bus inside switchboard. Connecting hardware supplied by switchboard manufacturer.
- Transformer throat connection includes gasketed box sized to match throat plus flexible straps and bolts. No Busway footage is included. For connection to transformers not manufactured by Siemens, consult factory

# Busway Power Distribution

XL-X, XL-U, BD Plug-In Units

Selection

## Circuit Breaker Plugs

As of June 2014, Siemens no longer supplies a complete solution for Legacy bus plug offerings.

### Floor Operable

Breaker Type	AC Volts	Ampere Rating	3-Phase, 3-Wire			3-Phase, 4-Wire		
			Enclosure Only <sup>②</sup>			Enclosure Only <sup>②</sup>		
			Catalog Number <sup>②</sup> XL-X	Catalog Number <sup>②</sup> XL-U	Catalog Number <sup>②</sup> BD Plug-In <sup>①②</sup>	Catalog Number <sup>②</sup> XL-X	Catalog Number <sup>②</sup> XL-U	Catalog Number <sup>②</sup> BD Plug-In <sup>①②③</sup>
ED2	240	15-60 70-100	REC3100G	UEC3100G	BEC3100	REC4100G	UEC4100G	BEC4100
ED4	480	15-60 70-100						
ED6	600	15-60 70-100						
FD6, FXD		70-250	RFC3250G	UFC3250G	BFC3250	RFC4250G	UFC4250G	BFC4250

### I-T-E Fusible Vacu-Break® Switch Plugs Floor-Operable with Line Terminal Protection

Volts	Ampere Rating	3-Phase, 3-Wire					3-Phase, 4-Wire				
		Horsepower Ratings		Catalog Number			Horsepower Ratings, AC		Catalog Number		
		Standard (NEC)	Maximum (Time Delay)	XL-X	XL-U	BD <sup>③</sup> Plug-In <sup>①</sup>	Standard (NEC)	Maximum (Time Delay)	XL-X	XL-U	BD <sup>③</sup> Plug-In <sup>①</sup>
250 AC or 250 DC	30	3	7½	RV321G	UV321G	BOS14321	3	7½	RV421G	UV421G	BOS16421
	60	7½	15	RV322G	UV322G	BOS14322	7½	15	RV422G	UV422G	BOS16422
	100	15	30	RV323G	UV323G	BOS14323	15	30	RV423G	UV423G	BOS16423
	200	25	60	RV324G	UV324G	BOS14324	25	60	RV424G	UV424G	BOS16424
600 AC	30	7½	20	RV361G	UV361G	BOS14351	5	15	RV461G	UV461G	BOS16451
	60	15	50	RV362G	UV362G	BOS14352	15	30	RV462G	UV462G	BOS16452
	100	30	75	RV363G	UV363G	BOS14353	25	60	RV463G	UV463G	BOS16453
	200	60	150	RV364G	UV364G	BOS14354	50	125	RV464G	UV464G	BOS16454

### Fuse Adapter Kits — RV and UV

Amperage	Class "J" Catalog Number	Class "T" Catalog Number	Class "R" Catalog Number
<b>240V AC/250V DC</b>			
30	④	④	W56626
60	④	④	W56628
100	④	TFAK32	W55365
200	④	TFAK42	W55366
<b>600V</b>			
30	④	④	W56627
60	④	④	W56629
100	④	TFAK35	W55365
200	④	TFAK45	W55366

### Field Addable Ground Kits for BD Bus Plugs Fusible

Ampere Rating	Catalog Number
30-60	W63231
100	W63232
200	W63233

Note: These are for use on busway with internal ground bus manufactured after March, 1986. For ground kits prior to this date, consult local sales office.

### Fuse Adapter Kits — BOS

Amperage	Class "J" Catalog Number	Class "T" Catalog Number	Class "R" Catalog Number
<b>240V AC/250V DC</b>			
30	④	④	W56626
60	④	④	W56628
100	W49827	TFAK32	W55365
200	W49819	TFAK42	W55366
<b>600V</b>			
30	W49832	④	W56627
60	W49830	④	W56629
100	W49828	TFAK35	W55365
200	W49818	TFAK45	W55366

① Grounding Finger — See table.

② Enclosures available from stock. When ordering circuit breaker bus plugs complete with breaker, factory-installed, allow time for assembly and SPECIFY enclosure frame size, phase and ampere rating. Example: One UEC3100—ED4—3P—70A—factory assembled

③ When BD busway capacity exceeds 400A for aluminum or 600A for copper, capacity must be specified to obtain proper number and arrangement of neutral fingers.

④ Not required.

⑤ Replace "—" with "1" or "2".

See Table: BD Bus Plug Catalog Number Ref. shown on Page 15-61.

# Busway Power Distribution

XL-X, XL-U and BD Plug-In Units and Cubicles

Selection

## Shipping Weights — Pounds

### For Circuit Breaker Bus Plugs Only

Breaker Type	Ampere Rating	3-Phase, 3-Wire				3-Phase, 4-Wire			
		Enclosure Only		Complete Assembly		Enclosure Only		Complete Assembly	
		XL-U XL-X	BD, LO-X	XL-U XL-X	BD, LO-X	XL-U XL-X	BD, LO-X	XL-U XL-X	BD, LO-X
ED2, ED4, ED6	15–100	12	14	13	15	13	15	14	10
FD6, FXD	70–250	1	27	51	37	45	28	55	38

### Fusible and Molded Case Circuit Breaker Cubicles

See page 15-33 for typical configurations.

## Shipping Weights — Pounds

### For Fusible Switch Bus Plugs Only

Switch Ampere Rating	3-Phase, 3-Wire		3-Phase, 4-Wire	
	XL-X XL-U	BD, LO-X	XL-X XL-U	BD, LO-X
	Prefix RV UV	Prefix BOS	Prefix RV UV	Prefix BOS
30,60	17	15	19	12
100	17	18	19	18
200	36	34	38	36

## BD Bus Plug Catalog Number Reference

Catalog Number	ABD4 Busway						BDP4 Busway						
	225 ABD402	400 ABD404	600 ABD406	800 ABD408	1000 ABD410	1200 ABD412	225 BDP402	400 BDP404	600 BDP406	800 BDP408	1000 BDP410	1350 BDP413	1600 BDP416
BOS16451	—	—	✓	—	✓	✓	—	—	—	—	—	✓	✓
BOS16452	—	✓	—	✓	—	—	—	✓	✓	✓	✓	—	—

As of June 2014, Siemens no longer supplies a complete solution for Legacy bus plug offerings.